

SECTION 41. THE FAZZĀN PROJECT: THE POTTERY TYPE SERIES

By J. N. Dore, A. Leone and J. Hawthorne

PART A. INTRODUCTION

This is the first attempt at constructing a full-scale pottery type series for a Central Saharan region, including both imported wares and locally produced ones in a wide range of fabrics and covering a long time period. To date little has been published in detail from earlier work in the region and nothing that comes close to being a proper type series (Ayoub and Abdel Salem 1968; Ayoub and Kilani 1968a/b; Daniels 1968; Fontana 1995; Pace *et al.* 1951). The recent Italian work in Wādi Tanezzūft (Gatto in Castelli *et al.* 2005, 95-100 and in Liverani 2006) provides some important parallels, but from a region that was on the periphery of the Garamantian state, not at its centre, and thus much less rich in the range of imported wares. The pottery which forms the basis of this type series has two sources:

1. The fieldwork conducted by Daniels (CMD) between 1958 and 1977.
2. The fieldwork conducted by the Fazzān Project (FP) between 1997 and 2001.

The fieldwork conducted by CMD between 1958 and 1977

The type series uses material from the excavations carried out by CMD at Zinkekrā, Tinda, Sāniat Jibril and Sāniat bin Huwaydī supplemented by material recovered during survey. The pottery from this work is for the most part in store at Jarma. Small quantities are in store in the UK. Due to deterioration of the original bags and labels, much of the pottery relating to CMD's work stored in Jarma cannot now be precisely linked to context. Most of the work of assembling a type series for the CMD work has therefore come from examination of the archive of drawings and fabric descriptions held in the UK. Additional information on this material has come from a number of sources:

- A small quantity of pottery which is held in the Daniels archive, mostly from the excavations at Zinkekrā.
- Notes, listings and tabulations (most importantly of the GER 011 – Sāniat bin Huwaydī – material) made by Charlotte Tagart in the early 1980s when she was CMD's research assistant.
- Re-examination in Jarma, in 2000, of small quantities of material whose provenance could be established. This included sites in CHA, LEK and ZOU and some of the material from GER 002 (Sāniat Jibril) and GER 011 (Sāniat bin Huwaydī).
- Drawing and fabric recording of selected samples of locatable material in Jarma museum, in 2000, 2001 and 2002.

The fieldwork conducted by the Fazzān Project between 1997 and 2001

Between 1997 and 2001 the Fazzān Project carried out systematic field survey in the following areas (see *AF* 1, 107-35 and Gazetteer, this volume, for details):

- GER 002 (Sāniat Jibril), 003 (old Jarma Area), 011 (Sāniat bin Huwaydī), 015 (Jarma Area), 016 (Jarma Area), 018 (Jarma Area), 026 (Jarma Area), 027 (Sāniat Sulaymān Krayda).
- ELH (al-Ḥaṭīya) 001, 003, 004, 005, 006, 008.
- CHA (al-Khara'iq) 026, 027
- GDB (Qaṣr Bin Dughba) 001
- TWE (Tuwash) 026, 027, 028.

All the representative rim fragments that were recovered have been included in the series, although the number was not large. There was also some reconnaissance survey undertaken at various points up and down the Wādi al-Ajāl and further afield, from which small amounts of pottery were collected.

Finally, the major excavations carried out by the Fazzān project at Jarma (*G1*) have informed the work on this initial type series, though only a limited amount of the pottery recovered from these is included in this provisional classification, as post-excavation work is still continuing.

Table 41.1 below summarises the areas from which pottery was recovered by the two projects.

Table 41.1 Key to sites and survey areas

Code	Area	Project
BBA	Bintbaya	CMD & FP
CHA	al-Khara'iq	CMD & FP
CLF	Ikhliif	CMD & FP
EDU	Dahān Ubārī	FP
ELH	al-Ḥaṭīya	CMD & FP
FJJ	al-Fjayj	CMD & FP
FUG	al-Fugar	CMD & FP
MAR	Qaṣr Māra	CMD & FP
GBD	Qaṣr Bin Dughba	CMD & FP
GEL	al-Qal'at	CMD & FP
GER 001	Jarma (Old Jarma)	CMD & FP
GER 001.3	Old Jarma, building complex 3 (temple) [some pottery from Ayoub's excavations marked as GER B]	CMD

Code	Area	Project
GER 001.4	Old Jarma, Building complex 4	CMD
GER 001.5/6/7	Old Jarma, building complexes 5/6/7 [the material comes from Ayoub's excavations, labelled GER C]	CMD
GER 002	Sāniat Jibrīl, Jarma area	CMD & FP
GER 003	Jarma Area	FP
GER 011	Sāniat bin Huwaydī, Jarma area	CMD & FP
GER 015	Jarma Area	FP
GER 016	Jarma Area	FP
GER 018	Jarma Area	FP
GER 026	Jarma Area	FP
GER 027	Sāniat Sulaymān Krayda, Jarma area	CMD & FP
GRA	Qarāqra	CMD & FP
GRE	al-Qrāya	CMD & FP
GSC	Jarma escarpment, includes some material from GSC 030 originally labelled ROY for 'Royal Cemetery'	CMD & FP
LAR	Lārkū	CMD & FP
LEK	al-Qṣīr	CMD & FP
RUG	ar-Raqayba	CMD & FP
TAG	Tāqallit	CMD & FP
TIN	Tinda	CMD & FP
TWE	Tuwash	CMD & FP
UAT	Waṭwāt	CMD & FP
ZIN	Zinkekrā	CMD & FP
ZOU	al-Zūwīya	CMD & FP
ZUL	Zuwīla	CMD & FP

Collection Methodology: CMD Fieldwork

While not resorting to the extensive gridding and transecting used in sampling today, CMD and his survey teams aimed to be thorough and systematic in their coverage of a site. Thus, while the samples that they collected are not susceptible to the kind of detailed analysis usually undertaken today, they are nevertheless at least reasonably representative of all the ceramic types available on the surface of a given site.

Analysis and Reporting Methodology: CMD Fieldwork

As far as one can judge from records in the field notebooks, all of the preliminary analysis and recording of the

material recovered from the excavations and survey was carried out in the field. Miriam Daniels was responsible for almost all of the drawing work and a considerable debt of gratitude is undoubtedly owed to her for ensuring that the archive of drawn material is as comprehensive as it is. Since there were few if any ceramicists specialising at that time in coarseware and amphorae, CMD undertook the cataloguing of the material and the recording of the fabric himself. He himself was not familiar with the common form and fabric types in the fineware and coarseware repertoires, and most of his descriptions are too basic to allow us now to identify common fabric types without seeing the original vessels. It seems probable that the cataloguing of the diagnostic material in the assemblage may not have been comprehensive in all cases. In 2000, a number of groups of material from field-survey sites (mainly sites in al-Khara'iq, al-Qṣīr and al-Zūwīya) was located in the store and washed and re-examined. This exercise revealed a number of vessels which had not previously been recorded, of which three were types which had not hitherto been recorded in the area (two late amphora types and one Tripolitanian Red Slip Ware type).

The Organisation of the Catalogue

Types have been defined principally on shape-related criteria and the assemblage has been divided into four major classes of vessel. The criteria for ordering types within each vessel class differs slightly from class to class. Table 41.2 shows the relationships between class and type and the criteria for ordering types within each class.

Within the entry for each type, details of the occurrence of individual vessels are tabulated. Most vessels are identified by a unique number (the 'CMD' number). A few are referenced otherwise. Site codes correspond to those given in Table 41.1. Descriptions of fabric given in the table under 'Other Information' have been taken from the CMD field notebooks and are given when it has not been possible to make a re-examination of any of the members of the type. Where re-examination and fabric recording has been possible and a generalisation on type-fabrics can be made this is given under a separate heading which precedes the table. At the head of each type entry is placed discussion of the formal criteria which define the type together with evidence for dating.

The organisation of the catalogue of handmade vessels deserves further comment. Since it has not been possible to re-examine more than a very small amount of the handmade assemblage collected by CMD no general series of fabric types can be established for this material. The fabric characterisations and descriptions noted by CMD and given in the tables under 'Other Information' are thus the only fabric information we now have for the assemblage; these descriptions should be treated with extreme caution. Of the two fabrics which he regularly notes, 'Zinkekrā' fabric and 'Berber Red' fabric, only the former can be regarded with any degree of probability

Table 41.2. Organisation of the Type series

Ware	Types	Description
Part B. Fineware	501-534	Types are grouped by ware – e.g. 'Sigillata', 'African Red Slip Ware' – and these are ordered chronologically.
Part C. Amphorae	1-44	Types are ordered chronologically.
Part D. Coarseware	101-244	Types are grouped into shape categories – e.g. 'large bowls', 'casserole', and broadly chronologically within each shape category.
Part E. Handmade	301-360	Types are grouped in terms of broad chronological periods – e.g. 1 st millennium BC, Roman period Garamantian, Medieval etc. This corresponds, generally with the sites from which it was collected, e.g. 1 st millennium BC material is, generally speaking, very largely from Zinkekrā, Roman period material is, very largely, from GER 002, etc.
Part F. Mesolithic/ Neolithic handmade		This is essentially an addendum to the catalogue

as being a definable fabric sharing common attributes. The latter, however, cannot be seen as such since CMD's notes make plain that his conception of the basis for its definition as a 'fabric' was far from constant.

A basic description of 'Zinkekrā' fabric is as follows: Hand-made, gritty black with burnished black surfaces; the most obvious inclusions are abundant, rounded grains of quartz, main fraction 0.3-2mm.

During the Fazzān Project handmade pottery of Mesolithic or Neolithic (Pastoral period) date was collected from a number of sites. This material has been kept separate from the type series and is reported on at the end (Part F, below). References to this material have been incorporated into the type series where relevant.

Abbreviations used in the Catalogue

Atlante = Hayes 1985

Conspectus Formarum = Ettliger *et al.* 1990

DZ [nos] = Daniels 1968 (for cross reference with his publication drawing numbers of selected forms from Zinkekrā)

Hayes = Hayes 1972

OCK = Oxe, Comfort and Kenrick 2000

The Character of the Assemblage

The reader is referred to Tables 41.4-41.7 (Summary of Pottery Types) and Tables 41.8-41.11 (Summary of the Distribution of Pottery Types in the Study Area). Full references to parallels cited for types are given in the respective sections of the catalogue.

The Earliest Pottery

The earliest pottery currently recorded within the study area by either the CMD or the Fazzān projects is of Mesolithic or early Pastoral Neolithic date. It consists of a wall sherd bearing 'dotted wavy-line' rocker decoration from TWE 021 and a wall sherd bearing packed rocker stamping from GRA 002 (see p.428 & 431, catalogue nos 2 and 21). Both of these sites are escarpment settlements, essentially Garamantian hillforts, and these pottery finds point to far earlier occupation of these locations than previously recognised.

Mid-Pastoral pottery has been identified from a number of the Holocene lithic scatters associated with shoreline encampments by the long-vanished palaeolakes in the sand sea (sites such as GER 033).

The Earliest Imported, Wheelmade Pottery

The earliest imported, wheelmade pottery from the study area dates, roughly speaking, to the last three centuries of the 1st millennium BC. The principal types are amphorae and large coarseware bowls usually characterised as late 'Punic' (types 1 – 5.1 and 101-106), Greco-Italic amphorae (type 10) amphorae of form Dressel 1A (types 11 and 12), a Hellenistic white-ground lagynos (type 507) and a series of small bowls in Black Gloss fabric (types 501-506). Our identification of the latter, it has to be said, is somewhat tentative, however; they were not identified as Black Gloss in the field notebooks but have been 'reverse engineered', so to speak, by trawling the drawings for possible black-gloss forms on the assumption that the ware ought to be present if other pottery dating to the last three centuries BC is attested. It is only fair to stress, also, that the actual vessels have not been re-examined.

Be that as it may, however, it is worth noting that a significant number of parallels for these forms (if black-gloss they be) occur in the Bab Bin Gascir necropolis in Tripoli (within the built-up area of modern Tripoli but, interestingly, a good 2.5 km SSE of what is usually assumed to have been the core of the ancient city).

For the late 'Punic' types it is worth noting that a significant proportion come from one site, Tinda. Seventy percent of amphora types 1-5.1 and 68 percent of coarseware types 101-106 come from this site, and, most interestingly, 94 percent of types 101-103 which are the types that might be considered the most 'Punic', that is, those with the best parallels from late Punic deposits, at Sabratha for example (Dore and Keay 1989) and at Carthage (see *Byrsa I and II*).

The Hellenistic white-ground lagynos (type 507) is of considerable interest. Its painted decoration can be very closely paralleled on vessels from the Athenian Agora (see catalogue for references) and the vessel can be dated to between c.150 BC and 50 BC. At present, as far as the authors are aware, it is unique in the Wādī al-Ajāl region (no fragments of other vessels have been noted in the assemblage studied for this volume nor among all the other material from the Fazzān seen in the course of

the project). The tomb in which it was found by Ayoub (GER 011, T A2.1) contained much later material suggesting that, at the time of its burial it had the status of an heirloom.

Fineware

The possible black-gloss types and the Hellenistic lagynos have already been mentioned above. In respect of the rest of the fineware assemblage recorded in this volume, there is an undeniable bias created by the large amount of material recovered from the cemetery of GER 011 (Sāniat bin Huwaydī). Seventy-three percent of the fineware included in this volume is from GER 011; of that material 58 percent is Italian Sigillata and of this 65 percent consists of type 515 (*Conspectus Formarum* 3.2). The stamps which appear on this form represent the principal Late Italian producers in the Pisa region and Philip Kenrick is of the opinion that the number of duplicate or near duplicate stamps suggests that most of this material may have arrived in the area as a single consignment on a single occasion.

Accompanying the Italian Sigillata are small amounts of Eastern Sigillata A (types 508-510), South Gaulish Sigillata (type 516) and a single example of a small glazed bowl (type 517) which is likely to be of Italian origin.

The remainder of the fineware series presented in this volume consists of African Red Slip Ware (types 518-530) and its Tripolitanian analogue, Tripolitanian Red Slip Ware (types 531-534), which cover the period from the late 1st century AD to somewhere in the 6th century AD. Whilst it is possible that what is presented here under-represents the occurrence of later fineware in the study area (we have already alluded to this possibility with respect to the material recovered by CMD from survey) we do not believe this to be markedly the case. At present we are not seeing evidence for supply of any great scale, or supply which is necessarily regularised or continuous throughout the period.

Amphorae

Twenty-eight percent of the amphorae recorded in this volume are virtually certain to have originated in Tripolitania (types 15-22). Slightly less certainty, though still a reasonable degree, can be expressed on the Tripolitanian origin of the late 'Punic' types (types 1-5.1), some of the Greco-Italics (type 10) and the mid-Roman type 26. Their inclusion would raise the proportion to around 36 percent. Of the certain candidates 35 percent (mostly the complete or near complete examples) were from the cemetery of Sāniat bin Huwaydī (GER 011).

The standard of manufacture of types 15, 16 and 19 is not particularly high. A number shows some evidence of overfiring, which has caused distortion at the rim. One example (*G1*, 764, from the FP excavations at Jarma, included here for comparison) shows the porous, biscuity texture of marked overfiring, which has resulted in severe

distortion. These features are not extreme or consistent enough to indicate manufacture of these vessels in the region, but they do suggest that containers bordering on the sub-standard were being used.

It is usually assumed that types 15-22 carried olive oil though this is far from proven. An examination of the capacities of those vessels complete enough to allow such figures to be estimated (see Table 41.3; see under type 19 for details of how these figures were obtained) shows that generally speaking they are quite small vessels. One might be tempted to suggest that of these the smaller vessels, in particular, held a commodity with a unit-value higher than olive oil; wine would be an obvious candidate though others could be suggested.

Following the mid-Roman period, represented by types 21 – 29, originating largely in Tripolitania with a small number from Tunisia, the number of amphorae types which can be assigned to the late Roman period is small. Late Roman Amphorae 1-4 (types 31-4) are present in small quantities, there is a single example of a Keay type 52 (type 35), and there are a number of types which are unassigned but probably late (types 37-43). As with fineware types 531-4 (Tripolitanian Red Slip), there is a possibility that the quantities of late amphorae have been underestimated since a number of them were only recognised after re-examination of groups in 2000, but probably not by overmuch.

Table 41.3: Estimated Capacities of Amphorae Types 15, 19 and 22

Type	Capacity (L)
15	17.4
15	24.9
15	28.4
15	29.6
19	18
19	19.5
19	20
19	20
19	20.5
19	25.6
19	36
19	41.3
19	42.5
22	15.5
22	22.6

Coarseware

For the coarseware it has to be admitted that there are few well recognised types which are at all common in the assemblage apart from various casserole types. We mention only the distinctive types.

Types 101-106 have already been mentioned in the section on early material (above). They have clear formal parallels with datable material of late 'Punic' date from e.g. Sabratha and Carthage. Type 107 has clear formal parallels with the series of early Roman basins which are well known from a large number of Mediterranean sites (see catalogue for references). Type 108 presents slightly more of a problem with respect to date. The fabric is the same as types 101-3 but some examples (most notably 3691) seem to exhibit formal similarities with the early Roman basin series and for this reason they have been dated slightly later than types 101-3, i.e. 1st century BC – 1st century AD. The concentration on the one site (Tinda) of a number of these early types (101-3 and 108, and see earlier for amphora types 1-5) is worth emphasising again though its implications are difficult to assess. It may simply reflect the amount of time spent by CMD and his team excavating and collecting material at that particular site.

Types 114 and 114.1 are known to have been produced in kilns at Leptiminus in Tunisia (Stirling *et al.* 2000).

Types 143-145 are known at Sabratha and in the pre-desert of Tripolitania, with types 143 and 144 occurring in quantity in the pre-desert. This distribution would suggest manufacture in Tripolitania though possibly at a different centre or centres from those producing standard (if there is such a thing) Tripolitanian Red Slip Ware since (as noted in Dore 1996, 386) the fabric is not particularly similar to TRS.

For the casserole types, the earlier series can be closely paralleled at Sabratha and in the pre-desert area with most of the types common in the period 1st century BC to late 2nd/early 3rd century AD being present. There is a preponderance of types originating from Tripolitania/Central Tunisia though the classic northern Tunisian types are also present (types 176 and 177). It is interesting to note the occurrence of type 178. Predominantly a Cyrenaican type it occurs in the pre-desert (in the ULVS survey area and at Bū Nijīm) but not (as far as we are aware) at Sabratha, all of which might suggest distribution by inland rather than sea-bourne routes. References to Garamantes in the Bū Nijīm ostraka could be relevant (Marichal 1992, nos 28, 71, 72 and 147).

The early – mid Roman levels at Sāniat Jibril (GER 002) are dominated by two types of deep casserole or basin: the first (types 180-6) is relatively undistinguished but the second has walls which are covered with parallel, equally spaced horizontal ridges (type 179). No close parallels for the latter are presently known outside the region. The fabric suggests an origin within the region and it may be that it was produced in the locality.

Type 179.1 is a type common to the pre-desert area in the mid – late Roman period and has affinities with Tripolitanian Red Slip ware.

Among the flagons, jugs and miscellaneous vessels there are several types which are worthy of note. The small jug or mug, type 204, is commonly encountered on coastal sites in Tunisia and Tripolitania, as well as in the pre-desert area, often in association with funerary contexts. The highly distinctive pedestal vase, type 216, if it was produced in the locality as seems likely, would seem indicative of the formal and decorative influence of Roman fineware on local traditions. The late 'Punic' – early Roman flagon series is well represented by types 218-220 all of which have good parallels on the coast at Sabratha and in the pre-desert area.

Handmade

The handmade assemblage covers the greatest span of time, from the early Holocene to the present day.

A general dating horizon is provided by CMD's fieldwork and excavations at Zinkekrā (excluding the cemetery areas on the lower slopes which are of Roman-period date) which provides its associated material with a general date of 1st millennium BC. There are what might be regarded as seven quintessentially Zinkekrā types. They are types 301-4, 307-8 and 310. The interrelated nature of their formal characteristics, the commonality of their fabric, and their abundant occurrence at Zinkekrā combine to suggest strongly that they be associated with the period of Zinkekrā's principal occupation which is dated by C¹⁴ to the 1st millennium BC.

Type 305 also occurs abundantly on Zinkekrā but in this case there are occurrences on other sites (principally sites located by the Fazzān Project in the inter-dune areas of the Ubārī sand-sea) which suggest that this was a type which originated earlier, conceivably as early as the middle Pastoral period and continued down into the 1st millennium BC. Again, the significance of types that connect the Garamantes with the earlier Pastoral peoples of the region cannot be overstated.

Other types whose association with Zinkekrā places them in the 1st millennium BC are 311, 315-17 and 322-326.

Types 333-340 can be dated by their occurrence at Sāniat Jibril (GER 002) to the period 1st-4th centuries AD.

The doka types 341-343 appear in contexts datable to the 1st century BC or 1st century AD. Thereafter they are common in 2nd- to 4th-century and early medieval levels.

Of the open bowl types with plain rims (345-348) only 1 (346) has any kind of secure date attached to it by virtue of its occurrence at GER 002.

Type 349-360 can all be dated to the modern period on the basis of the occurrence in 19th- and 20th-century levels in the Fazzān Project's excavations at GER 001.

Table 41.4 Summary of Pottery Types: Fineware

501	Black or Red Gloss Cups of Hellenistic Date	2nd - 1st century BC
502	Black or Red Gloss Cups of Hellenistic Date	2nd - 1st century BC
503	Black or Red Gloss Cups of Hellenistic Date	2nd - 1st century BC
504	Black or Red Gloss Cups of Hellenistic Date	2nd - 1st century BC
505	Black or Red Gloss Cups of Hellenistic Date	2nd - 1st century BC
506	Black or Red Gloss Cups of Hellenistic Date	2nd - 1st century BC
507	Hellenistic White-ground Lagynos	2nd - 1st century BC
508	Eastern Sigillata A	Late 1st - Early 2nd century AD
509	Eastern Sigillata A	Late 1st - Early 2nd century AD
510	Eastern Sigillata A	Late 1st - Early 2nd century AD
511	Italian Sigillata	Mid-Late 1st century AD
512	Italian Sigillata	Mid-Late 1st century AD
513	Italian Sigillata	Late 1st century AD
514	Italian Sigillata	Mid-Late 1st century AD
515	Italian Sigillata	Late 1st century AD
516	South Gaulish Sigillata	Late 1st - Early 2nd century AD
517	Glazed Ware (Italian?)	Late 1st century AD?
518	African Red Slip Ware	Late 1st century AD
519	African Red Slip Ware	Late 1st - Early 2nd century AD
520	African Red Slip Ware	Early-Mid 2nd century AD
521	African Red Slip Ware	Late 1st - Early 2nd century AD
522	African Red Slip Ware	Late 1st - Mid 2nd century AD
523	African Red Slip Ware	Late 1st - 2nd century AD
524	African Red Slip Ware	Late 1st - 2nd century AD
525	African Red Slip Ware	Mid 5th century AD
526	African Red Slip Ware	2nd half of 5th century AD
527	African Red Slip Ware	Late 5th - Mid 6th century AD
528	African Red Slip Ware	Late 1st - 2nd century AD

529	African Red Slip Ware	2nd century?
530	African Red Slip Ware	Late 1st - Mid 2nd century AD
531	Tripolitanian Red Slip Ware	Late 3rd - 4th century AD
532	Tripolitanian Red Slip Ware	4th century AD +
533	Tripolitanian Red Slip Ware	5th century AD +
534	Tripolitanian Red Slip Ware	6th century AD +

Table 41.5: Summary of Pottery Types: Amphorae

1	Late 'Punic'	3rd - 1st century BC
2	Late 'Punic'	3rd - 1st century BC
3	Late 'Punic'	3rd - 1st century BC
4	Late 'Punic'	3rd - 1st century BC
5	Late 'Punic'	3rd - 1st century BC
5.1	Late 'Punic'	3rd - 1st century BC
6	Small Amphoroid Jar	1st century BC - 1st century AD?
7	Small Amphoroid Jar	1st century BC - 1st century AD?
8	Small Amphoroid Jar	1st century BC - 1st century AD?
9	Amphoroid Jar	1st century BC - 1st century AD?
10	Greco-Italic	3rd - 2nd century BC
11	Probable Dressel 1A	2nd - 1st century BC
12	Dressel 1A	2nd - 1st century BC
13	Miscellaneous Hellenistic	2nd - 1st century BC?
14	Benghazi Early Roman Amphora Type 6	Late 1st century BC - early 2nd century AD
15	Early Roman Tripolitanian	Late 1st century BC - 1st century AD?
16	Early Roman Tripolitanian	Late 1st century BC - 1st century AD?
17	Early Roman Tripolitanian	Late 1st century BC - 1st century AD?
18	Early Roman Tripolitanian	Late 1st century BC - 1st century AD?
19	Early-Mid Roman Tripolitanian	1st - 2nd century AD
20	Miscellaneous Early-Mid Roman Tripolitanian	1st - 2nd century AD
21	Mid Roman Tripolitanian	2nd - 4th century AD
22	Mid Roman Tripolitanian?	2nd - 4th century AD
23	Mid Roman Tunisian (Keay Type LIX)	2nd - 4th century AD

24	Mid Roman Tunisian (Africano Piccolo)	2nd - 4th century AD
25	Mid Roman Tunisian (Africano Grande)	2nd - 4th century AD
26	Mid Roman Tripolitanian?	2nd - 4th century AD?
27	Mid Roman	2nd - 4th century AD
28	Mid Roman	2nd - 4th century AD
29	Benghazi Mid Roman Amphora 7	3rd - 4th century AD
30	Spathaia	5th - 6th century AD
31	Late Roman Amphora 1	5th - 7th century AD
32	Late Roman Amphora 2	Late 4th - late 6th century AD
33	Late Roman Amphora 3	5th - 6th century AD
34	Late Roman Amphora 4	Late 4th - late 6th century AD
35	Keay Type 52	4th - 6th century AD
36	Late Roman	5th - 6th century AD
37	Unassigned probably late	5th - 7th century AD?
38	Unassigned probably late	5th - 7th century AD?
39	Unassigned probably late	5th - 7th century AD?
40	Unassigned probably late	5th - 7th century AD?
41	Unassigned probably late	5th - 7th century AD?
42	Unassigned probably late	5th - 7th century AD?
43	Unassigned probably late	5th - 7th century AD?
44	Miscellaneous unassigned.	

Table 41.6: Summary of Pottery Types: Coarseware

101	Large bowl - Late 'Punic'	3rd - 1st century BC
102	Large bowl - Late 'Punic'	3rd - 1st century BC
103	Large bowl - Late 'Punic'	3rd - 1st century BC
104	Large bowl - Late 'Punic'	3rd - 1st century BC
105	Large bowl - Late 'Punic'	3rd - 1st century BC
106	Large bowl - Late 'Punic'	3rd - 1st century BC
107	Large bowl - Early Roman	1st century BC - 1st century AD
108	Large bowl - Early Roman?	1st century BC - 1st century AD?
109	Large bowl - Early Roman?	1st century BC - 1st century AD?
110	Small finely made bowl - Early Roman?	1st century BC - 1st century AD?
111	Large bowl with flange rim - Early Roman?	1st century BC - 1st century AD?
112	Large bowl - Mid Roman	2nd - 4th century AD

113	Large bowl - Mid Roman	2nd - 4th century AD
114	Medium bowl - Mid Roman	Late 2nd - 4th century AD
115	Medium bowl - Mid-Late Roman	2nd - 5th century AD
116	Miscellaneous large bowl	?
117	Miscellaneous large bowl	?
118	Finely made medium bowl - Mid Roman	2nd - 3rd century AD
119	Finely made medium bowl - Mid Roman	2nd - 3rd century AD
120	Finely made medium bowl - Mid Roman?	2nd - 3rd century AD?
121	Finely made medium bowl - Mid Roman?	2nd - 3rd century AD?
122	Finely made medium bowl - Mid Roman?	2nd - 3rd century AD?
123	Finely made medium bowl - Mid Roman	2nd - 3rd century AD?
124	Finely made medium bowl - Mid Roman?	2nd - 3rd century AD?
125	Medium bowl (possibly fineware related) - Mid Roman	Late 3rd - 4th century AD?
126	Miscellaneous Large or medium bowl - Mid-Late Roman?	2nd - 5th century AD?
127	Miscellaneous Large or medium bowl - Mid-Late Roman?	2nd - 5th century AD?
128	Miscellaneous Large or medium bowl - Mid-Late Roman?	2nd - 5th century AD?
129	Miscellaneous Large or medium bowl - Mid-Late Roman?	2nd - 5th century AD?
130	Miscellaneous Large or medium bowl - Mid-Late Roman?	2nd - 5th century AD?
131	Miscellaneous Large or medium bowl - Mid-Late Roman?	2nd - 5th century AD?
132	Miscellaneous Large or medium bowl - Mid-Late Roman?	2nd - 5th century AD?
133	Miscellaneous Large or medium bowl - Mid-Late Roman?	2nd - 5th century AD?
134	Miscellaneous Large or medium bowl - Mid-Late Roman?	2nd - 5th century AD?
135	Miscellaneous Large or medium bowl - Mid-Late Roman?	2nd - 5th century AD?
136	Miscellaneous Large or medium bowl - Early-Mid Roman	1st - 4th century AD

137	Medium and small bowls with flange rims - Early-Mid Roman	1st - 2nd century AD
138	Medium and small bowls with flange rims - Early-Mid Roman	1st - 2nd century AD
139	Medium and small bowls with flange rims - Mid Roman	1st - 4th century AD
140	Medium and small bowls with flange rims - Early-Mid Roman	1st - 2nd century AD
141	Medium and small bowls with flange rims - Early-Mid Roman	1st - 2nd century AD
142	Medium and small bowls with flange rims - Early-Mid Roman	1st - 2nd century AD
143	Small carinated bowls with plain rims - Mid Roman	3rd - 4th century AD
144	Small carinated bowls with plain rims - Mid Roman?	3rd - 4th century AD?
145	Small carinated bowls with plain rims - Mid Roman	2nd - 4th century AD
146	Miscellaneous bowl imitating a glass form - Early-Mid Roman	1st - 2nd century AD?
147	Large bowl with plain rim - Mid-Roman	3rd - 4th century AD
148	Large bowl with plain rim	?
149	Medium bowl with plain intumed rim - mid Roman?	2nd - 4th century AD?
150	Medium bowl with plain intumed rim - mid Roman?	2nd - 4th century AD?
151	Medium bowl with plain intumed rim - mid Roman?	2nd - 4th century AD?
156	Medium bowl with plain intumed rim	?
157	Medium bowl with plain rim - mid Roman	2nd - 3rd century AD
158	Medium bowl with plain rim	?
159	Small bowl with plain rim	?
160	Small bowl with plain rim	?
161	Small bowl with plain rim - mid Roman	2nd - 3rd century AD
162	Small bowl with plain rim - mid Roman	3rd - 4th century AD
163	Small bowl with plain rim	?
164	Small bowl with plain rim	?

165	Small bowl or cup with plain rim	?
166	Small bowl with plain rim	?
167	Small bowl or cup with plain rim	?
168	Small bowl or cup with plain rim	?
169	Small bowl or cup with plain rim	?
170	Mortarium - Early Roman	1st century BC - 1st century AD
171	Casserole - Late 'Punic'/ Early Roman	3rd - 1st century BC
171.1	Casserole - Tripolitanian/ Central Tunisian - Early Roman	1st century AD
172	Casserole - Tripolitanian/ Central Tunisian - Early-Mid Roman	1st - 3rd century AD
173	Casserole - Tripolitanian/ Central Tunisian - Mid Roman	2nd - 4th century AD
174	Casserole - Tripolitanian/ Central Tunisian - Mid Roman	2nd - 4th century AD
175	Casserole - Tripolitanian/ Central Tunisian - Mid-Late Roman	3rd - 5th century AD
176	Casserole - North Tunisian - Mid Roman	2nd - 4th century AD
177	Casserole - North Tunisian - Early-Mid Roman	1st - 2nd century AD
178	Casserole - Benghazi Mid Roman Cooking Ware 1	2nd - 5th century AD
179	Casserole - Tripolitanian - Mid-Roman	2nd - 4th century?
179.1	Casserole - Tripolitanian - Mid-Late Roman	4th - 5th century AD (+?)
180	Casserole or basin - Tripolitanian - Early-Mid Roman	1st - 2nd century AD?
181	Casserole or basin - Tripolitanian - Early-Mid Roman	1st - 2nd century AD?
182	Casserole or basin - Tripolitanian - Early-Mid Roman	1st - 2nd century AD?
183	Casserole or basin - Tripolitanian - Early-Mid Roman	1st - 2nd century AD?
184	Casserole or basin - Tripolitanian - Early-Mid Roman	1st - 2nd century AD?
185	Casserole or basin - Tripolitanian - Early-Mid Roman	1st - 2nd century AD?

186	Casserole or basin - Tripolitanian - Early-Mid Roman	1st - 2nd century AD?
187	Casserole or large bowl	?
188	Casserole or large bowl	?
189	Casserole - Mid-Late Roman	5th - 6th century AD?
190	Casserole or large jar	?
191	Casserole or large jar	?
192	Casserole or large jar - Mid Roman?	2nd - 3rd century?
193	Casserole or large jar - Mid Roman?	2nd - 3rd century?
194	Casserole or large jar - Mid Roman?	2nd - 3rd century?
195	Jar	?
196	Jar	?
197	Jar	?
198	Jar	?
199	Jar	?
200	Jar	?
201	Jar	?
202	Jar	?
203	Jar	1st - 2nd century AD
204	Mug - Early-Mid Roman	2nd - 3rd centuries AD
205	Two-handled flask or feeder	?
206	Small stemmed cup	?
207	Unguentarium	?
208	Unguentarium	?
209	Unguentarium	?
210	Unguentarium	?
211	Lid - Early-Mid Roman	2nd - 4th century AD
212	Lid - Early-Mid Roman	2nd - 4th century AD
213	Lid - Early-Mid Roman	2nd - 4th century AD
214	Lid - Early-Mid Roman	2nd - 4th century AD
215	Lid - Early-Mid Roman	2nd - 4th century AD
216	Pedestal vase	1st century AD
217	Base fragments from pedestal vases	1st century AD
218	Early Roman	1st - 3rd century AD
218.1	Amphoroid flagon - Early Roman	1st - 3rd century AD

219	Amphoroid flagon - Early Roman	1st - 3rd century AD
220	Amphoroid flagon - Early Roman	1st - 3rd century AD
221	Flagon - Mid-Late Roman	3rd century AD +
222	Two-handled flagon or flask	1st - 2nd century AD
223	Large flagon	Late?
224	Large flagon	Late?
225	Flagon - mid Roman	2nd - 4th century AD
226	Flagon - mid Roman	2nd - 4th century AD
227	Flagon - mid Roman?	4th century AD ?
228	Flagon - mid Roman?	2nd - 4th century AD?
229	Flagon	?
230	Jug - Carthage Late Roman Jug 1	4th - 6th century AD
231	Flagon or Jug	Late?
232	Jug - Similar to Carthage Late Roman Jug 3	4th - 6th century AD
233	Jug - Carthage Late Roman Jug 3	4th - 6th century AD
234	Flagon	?
235	Flagon	?
236	Flagon	?
237	Flagon	?
238	Flagon	?
239	Flagon or jug	?
240	Flagon or jug - mid Roman	2nd - 4th century AD
241	Flagon	?
242	Flagon - mid Roman	2nd - 4th century
243	Flagon - mid Roman	2nd - 4th century?
244	Flagon or bowl	Islamic

Table 41.7. Summary of Pottery Types: Handmade

301	Deep wide-mouth jar or bowl	1st millennium BC
302	Wide-mouth jar or bowl	1st millennium BC
303	bowl	1st millennium BC
304	Deep wide-mouth jar or bowl	1st millennium BC
305	Deep jar with restricted mouth	1st millennium BC (and earlier?)
306	Deep jar with restricted mouth	1st millennium BC
307	Open bowl or dish	1st millennium BC

308	Open bowl or dish	1st millennium BC
309	Open bowl or dish	1st millennium BC
310	Open bowl or dish	1st millennium BC (and earlier?)
310.1	Small bowl or cup with inturned lip	1st millennium BC (and earlier?)
311	Necked jar	1st millennium BC
312	Deep jar with restricted mouth and provision for lid	?
313	Small jars with bead rims	1st millennium BC
314	Necked wide-mouth bowl or jar	Mid/Late Pastoral
315	Everted rim jar	1st millennium BC (and earlier?)
316	Everted rim jar	1st millennium BC
317	Jar	1st millennium BC
318	Small everted rim jar	1st - 3rd century AD
319	Small everted rim bowl or jar	1st - 3rd century AD
320	Large jar with tall upright rim	Late 1st millennium BC - 3rd century AD
321	Deep jar	Late 1st millennium BC - 3rd century AD
322	Jar	1st millennium BC
323	Jar	1st millennium BC
324	Jar	1st millennium BC
325	Necked jar	1st millennium BC
326	Necked shouldered jar with flange rim	1st millennium BC
327	Small jar	1st millennium BC
328	Miscellaneous deep bowl or jar	?
329	Miscellaneous deep bowl or jar	?
330	Narrow-mouth jar	1st millennium BC
331	Narrow-mouth jar	1st millennium BC
332	Narrow-mouth jar	?
333	Globular jar with tall neck; painted decoration	1st - 4th centuries AD
334	Globular jar with tall neck and flange rim; painted decoration	1st - 4th centuries AD
335	Ovoid jars with vertical lug handles and painted decoration	3rd - 4th centuries AD +
336	Handled cups or incense burners	Medieval?
337	Globular jars with everted rims	1st - 4th century AD

338	Globular jars with everted rims	1st - 4th century AD
339	Globular jars with everted rims	1st - 4th century AD
340	Globular jars with everted rims	1st - 4th century AD
341	Doka	1st millennium BC
342	Doka	1st - 4th century AD
343	Doka	1st - 4th century AD
345	Small hemispherical bowls with plain rim	1st - 4th century AD
346	Small and medium bowls and dishes	1st-4th century AD
347	Small and medium bowls and dishes with developed rims	1st - 4th century AD
348	Miscellaneous vessels	
349	Miscellaneous everted rim jars	Medieval or Modern?
350	Miscellaneous everted rim jars	Medieval or Modern?
351	Jars with tall rims for lid seating	?
352	Miscellaneous deep jars with inturned rims	?
353	Deep jars with inturned rims and lug handles	Modern?
354	Jars with inturned rims and lug handles upstanding above the rim	Modern?
355	Round bottom jar with inturned rims and large handles with peaked lugs	Modern?
356	Handled bowls with ring handles	Modern?
357	Handled bowls with lug handles	Modern?
358	Miscellaneous jars and bowls	
359	Lids	
360	Everted rim jar with painted decoration	Post-Medieval

Table 41.8. Distribution of Pottery Types in the Study Area: Fineware

	Type	CMD no.	Context
FW	501	286	ZIN 291
FW	502	273	ZIN 109 (13)
FW	503	3016	FJJ 002 (9)
FW	504	1213	GSC 008 (1)
FW	505	1966	CHA 001

	Type	CMD no.	Context
FW	505	1967	CHA 001
FW	505	332	FJJ 002 (6)
FW	505	3332	GER 002 (132, s)
FW	505	2630	GER 002 (6, 9)
FW	505	1350	GSC 008
FW	505		GSC 016
FW	505	1839	UAT 004 (7)
FW	505	705	ZIN 296
FW	506	3010	FJJ 002 (13)
FW	507	(H42)	GER 011 (T A2.1)
FW	508	4118	GER 011 (T 17AJ)
FW	509	4122	GER 011 (T 17AA)
FW	510		Jama area
FW	511	4133	GER 011 (T 17AB)
FW	512	4137	GER 011 (T 17AS)
FW	512	4126	GER 011 (T 17AL)
FW	513	4108	GER 011 (T 15F)
FW	513	4100	GER 011 (T 15G)
FW	513	4123	GER 011 (T 17I)
FW	513	4139	GER 011 (T 17J)
FW	514	4149	GER 011 (T 17AF)
FW	515	4106	GER 011 (T 15L)
FW	515	4104	GER 011 (T 15M)
FW	515	4102	GER 011 (T 15H)
FW	515	4105	GER 011 (T 15K)
FW	515	4103	GER 011 (T 15N)
FW	515	4131	GER 011 (T 17AN)
FW	515	4134	GER 011 (T 17AM)
FW	515	4135	GER 011 (T 17S)
FW	515	4115	GER 011 (T 17AW)
FW	515	4112	GER 011 (T 17BF)
FW	515	4120	GER 011 (T 17AC)
FW	515	4129	GER 011 (T 17AT)
FW	515	4127	GER 011 (T 17AQ)
FW	515	4121	GER 011 (T 17AD)
FW	515	4125	GER 011 (T 17BE)
FW	515	4114	GER 011 (T 17K)
FW	515	4116	GER 011 (T 17AU)
FW	515	4119	GER 011 (T 17BG)

	Type	CMD no.	Context
FW	515	4111	GER 011 (T 17AV)
FW	515	4136	GER 011 (T 17X)
FW	515	4130	GER 011 (T 17BA)
FW	515	4117	GER 011 (T 17Y)
FW	515	4124	GER 011 (T 17AZ)
FW	515	4128	GER 011 (T 17AX)
FW	515	4110	GER 011 (T 17AI)
FW	515	4138	GER 011 (T 17AQ)
FW	515	4132	GER 011 (T 17AR)
FW	515	4113	GER 011 (T 17AH)
FW	515	4253	GER 011 (T 42M)
FW	515	4226	GER 011 (T 52K)
FW	515	4225	GER 011 (T 52Q)
FW	515	4229	GER 011 (T 52S)
FW	515	4228	GER 011 (T 52R)
FW	515	4227	GER 011 (T 52J)
FW	515	1417	GER 001.3
FW	516	4220	GER 011 (T 52H)
FW	517	4243	GER 011 (T 51H)
FW	518	(H66)	GER 011 (T A2.1)
FW	519	(H64)	GER 011 (T A2.3)
FW	519	(H67)	GER 011 (T A2.4)
FW	519	4101	GER 011 (T 15O)
FW	519	(H70)	GER 011 (T A2.1)
FW	519	(H68)	GER 011 (T A2.4)
FW	519	(H69)	GER 011 (T A2.4)
FW	519	(H27)	GER 011 (T A2.4)
FW	519	4235	GER 011 (T 51S)
FW	520	(H77)	GER 011 (T A2.3)
FW	521	(H30)	GER 011 (T A2.2)
FW	522	(H32)	GER 011 (T A2.1)
FW	522	(H71)	GER 011 (T A2.4)
FW	523	(H96)	GER 011 (T A2.2)
FW	523		GER 011 (T A2.3)
FW	523	(H33)	GER 011 (T A2.3)
FW	523	(H72)	GER 011 (T A2.3)
FW	523	(H73)	GER 011 (T A2.3)
FW	523	(H75)	GER 011 (T A2.3)
FW	523	(H74)	GER 011 (T A2.4)

	Type	CMD no.	Context
FW	523	(H76)	GER 011 (T A2.4)
FW	524	(H41)	GER 011 (T A2.3)
FW	524	1368	ZIN 119
FW	525		GSC 030 (T 4)
FW	526		ZOU 002
FW	527	(H29)	GSC 030 (T 14)
FW	528	(H12)	Jarma area
FW	528	(H7)	Jarma area
FW	529	4236	GER 011 (T 51T)
FW	530	4289	GER 011 (T 9F)
FW	531	4055	GER 011 (T 14A)
FW	531	2353	GER 002 (6, 10)
FW	531	(H24/26)	GSC 030 (T 3)
FW	532	(H93)	GER 011
FW	532		GSC 030 (T 4)
FW	532		LEK 009
FW	533	(H37)	GER 011
FW	533		ZOU 002
FW	534		LAR 003

Table 41.9. Distribution of Pottery Types in the Study Area: Amphorae

	Type	CMD no.	Context
AM	1	3587	TIN 001 (BE, G)
AM	2	3647	TIN 001 (A, 18, S)
AM	2	3608	TIN 001 (BE, B)
AM	3	1071	GSC 008 (1)
AM	4		GER 001 (G1, 802D)
AM	4	3595	TIN 001 (BE, A)
AM	4	3607	TIN 001 (BE, B)
AM	5	3697	TIN 001 (B, 17, S)
AM	5	3696	TIN 001 (B, 17, S)
AM	5.1	1103	ZIN 220
AM	6	7000	Jarma area
AM	7	7001	Jarma area
AM	8	1010	GSC 002
AM	9		GER 001 (G1, 733)
AM	9	4158	GER 011 (T 17G)
AM	9	128	GER 011 (T 17H)
AM	9	4160	GER 011 (T 17F)

	Type	CMD no.	Context
AM	10		GER 001 (G1, 863)
AM	10		GER 001 (G1, 889)
AM	10		GER 001 (G1, 950)
AM	10	3381	GER 002 (2 G)
AM	10	1542	GSC 017
AM	11	6041	GER 001.3
AM	11	1846	GER 001.3
AM	11	3701	TIN 001 (B, 17, S)
AM	11	3704	TIN 001 (B, 21, S)
AM	11	3710	TIN 001 (B, 21, S)
AM	11	6035	TIN 001 (BE, B)
AM	12	3597	TIN 001 (BE, A)
AM	13	2017	GER 001.3
AM	13	3809	RUG 002
AM	14	3634	TIN 001 (A2, 4)
AM	15	4148	GER 011 (T 17E)
AM	15	4146	GER 011 (T 17A)
AM	15	4239	GER 011 (T 52A)
AM	15	4251	GER 011 (T 42E)
AM	16	1845	Jarma area
AM	16	2029	GER 001
AM	16		GER 001 (G1, 764)
AM	16	1833	GER 001.3
AM	16	2020	GER 001.3
AM	16	2026	GER 001.3
AM	16	1942	GER 001.3
AM	16		GER 001.3
AM	16	1847	GER 001.3
AM	16	1940	GER 001.3
AM	16	3344	GER 011 (8, 1)
AM	16	3602	TIN 001 (BE)
AM	16	4183	TWE 002 (c)
AM	16	4177	TWE 002 (c)
AM	16	3534	ZOU 002
AM	17		GER 001 (G1, 841B)
AM	18	4212	GER 011 (T 51S)
AM	19	4142	GER 011 (T 15A)
AM	19	4164	GER 011 (T 1A)
AM	19	4145	GER 011 (T 17C)

	Type	CMD no.	Context
AM	19	4144	GER 011 (T 15B)
AM	19	4157	GER 011 (T 15C)
AM	19	4161	GER 011 (T 17B)
AM	19	4248	GER 011 (T 42B)
AM	19	4242	GER 011 (T 51V)
AM	19	4241	GER 011 (T 52E)
AM	19	4295	GER 011 (T 53A)
AM	20	871	Jarma area
AM	20	1989	CHA 001
AM	20	1993	CHA 001 (g)
AM	20	2022	GER 001
AM	20	3376	GER 002 (2, 4)
AM	20	2021	GER 001.4 (8)
AM	20	3867	GRE 001
AM	21	1991	CHA 001 (g)
AM	21	1992	CHA 001 (g)
AM	21	2028	GER 001
AM	21	1677	GER 001 (5)
AM	21	3343	GER 002 (8, 1)
AM	21	3371	GER 002 (4, 119)
AM	21	2782	GER 002 (7, 64)
AM	21	3377	GER 002 (g)
AM	21	829	GER 001.4 (11)
AM	21	1866	GER 001.4 (99)
AM	21	3612	TIN 001 (BE, B)
AM	21	4174	TWE 002 (B)
AM	22	4247	GER 011 (T 42A)
AM	22	4280	GER 011 (T 53H)
AM	23		GER 016 (Grab)
AM	23	2764	LAR 002 (S)
AM	24	1716	GER 001.3
AM	24	2499	GER 002 (2, 67)
AM	24	2639	GER 002 (2, 67)
AM	24	2771	GER 002 (4, 92?)
AM	24	1863	GER 001.4 (99)
AM	24	4281	GER 011 (T 6/A1.4)
AM	25	6022	GER 001.3
AM	25		LEK 006
AM	25	3698	TIN 001

	Type	CMD no.	Context
AM	26	4143	GER 011 (T 17W)
AM	26	4250	GER 011 (T 42D)
AM	26	4237	GER 011 (T 52C)
AM	26	4282	GER 011 (T 9A, 150)
AM	26	4279	GER 011 (T 9B)
AM	27	4147	GER 011 (T 15C)
AM	27	4275	GER 011 (T 53F)
AM	28	4294	GER 011 (T53B)
AM	29		ZOU 002
AM	30	2999	CHA 001
AM	30	1314	GSC 003 (G)
AM	31		CLF 003
AM	31		GBD 001 (NW Quad)
AM	31	3842	GRE 001A
AM	31		LEK 009
AM	31		GSC 030 (T 20/21F)
AM	32		LAR 010
AM	32		ZOU 002
AM	33	3040	CHA 001
AM	33		GSC 001 (C)
AM	34		LEK 009
AM	35		ZOU 002
AM	36	3725	RUG 001 (G)
AM	37	3451	CLF 002
AM	38	3535	ZOU 002 (G)
AM	39	3018	FJJ 006 (1)
AM	40	1941	GER 003 (115)
AM	41		BBA 015
AM	42	1312	GSC 005 (g)
AM	43	156	TAG 001 (G01)
AM	44	6000	Jarma area
AM	44	1919	Jarma area
AM	44	3609	Jarma area
AM	44	6017	GER 016 (909)
AM	44	2336	GER 002 (2, 12)
AM	44	2436	GER 002 (2, 30)
AM	44	2638	GER 002 (4, 30)
AM	44	3679	TIN 001 (B, 12, S)
AM	44	3695	TIN 001 (B,17, S)

	Type	CMD no.	Context
AM	44	3610	TIN 001 (BE, B)
AM	44	1929	CHA 001
AM	44	2999	CHA 001
AM	44	1977	CHA 001
AM	44	1972	CHA 001 (g)
AM	44	1971	CHA 001 (g)
AM	44	1992	CHA 001 (g)
AM	44	3452	CLF 002
AM	44	3845	FJJ 006
AM	44	3082	FJJ 006 (2)
AM	44		TAG 001
AM	44		CHA 001 (grab)
AM	44	1334	GER 002
AM	44	3049	FUG 003
AM	44	3560	GEL 004 (G)
AM	44		GER 002
AM	44	1569	GER 001.1
AM	44	6051	GER 001.3
AM	44	6003	GER 001.3
AM	44	6023	GER 001.3
AM	44	6015	GER 001.3
AM	44	2337	GER 001.3
AM	44	2276	GER 001.3 (2, 13)
AM	44	2713	GER 001.3 (7, 55)
AM	44	2526	GER 002
AM	44	3102	GER 002
AM	44	3374	GER 002
AM	44	2780	GER 002
AM	44	2705	GER 002
AM	44	2636	GER 002
AM	44	2079	GER 003 (113)
AM	44	1069	GSC 003
AM	44	1346	GSC 006 (g)
AM	44	1013	GSC 001
AM	44	4026	LEK 007 (S)
AM	44	3819	LEK 009
AM	44	3235	RUG 003
AM	44	3694	TIN 001 (B)
AM	44	4043	TIN 001 (B)

	Type	CMD no.	Context
AM	44	3594	TIN 001 (BE, A)
AM	44	3596	TIN 001 (BE, A)
AM	44	6034	TIN 001 (BE, B)
AM	44	3588	TIN 001 (BE)
AM	44	4175	TWE 002
AM	44	4174	TWE 002 (B)
AM	44	1602	ZIN 001-003
AM	44	566	ZIN 001-003
AM	44	614	ZIN 109 (12)
AM	44	3541	ZOU 002
AM	44	3541	ZOU 002
AM	44	3533	ZOU 002

Table 41.10. Distribution of Pottery Types in the Study Area: Coarseware

	Type	CMD no.	Context
CW	101	766	GER 001.3
CW	101	770	GER 001.3
CW	101	3663	TIN 001 (A)
CW	101	3702	TIN 001 (B, 17, s)
CW	101	3708	TIN 001 (B, 23, s)
CW	101	3682	TIN 001 (B, 12, a)
CW	101	3617	TIN 001 (BE)
CW	101	3708	TIN 001 (BE)
CW	101	3582	TIN 001 (BE)
CW	102	3834	TIN 001 (A)
CW	102	3645	TIN 001 (A)
CW	102	3636	TIN 001 (A)
CW	102	3690	TIN 001 (B, 15, G)
CW	102	3621	TIN 001 (BE)
CW	103	3021	FJJ 004
CW	103	3675	TIN 001
CW	103	3678	TIN 001 (B, 12, s)
CW	103	3677	TIN 001 (B, 1, SF)
CW	104	3020	FJJ 002
CW	104		GER 002 (60, s)
CW	104	1420	GER 002 (D, g)
CW	104	3238	GRE 001
CW	105	1570	GSC 016
CW	106	1675	GSC 016

	Type	CMD no.	Context
CW	107	1907	FUG 001
CW	108	3019	FJJ 003
CW	108	1324	GSC 008
CW	108	1561	GSC 013
CW	108	3680	TIN 001 (B, 12, s)
CW	108	3692	TIN 001 (B, 15, s)
CW	108	3691	TIN 001 (B, 15, s)
CW	108	3792	TIN 001 (B)
CW	108	3705	TIN 001 (B)
CW	108	3658	TIN 001 (B)
CW	108	3599	TIN 001 (B)
CW	108	3679	TIN 001 (B, 12, s)
CW	108	3585	TIN 001 (BE)
CW	108	3626	TIN 001 (BE)
CW	108	3583	TIN 001 (BE)
CW	108	3624	TIN 001 (BE)
CW	108	3618	TIN 001 (BE)
CW	108	1040	ZIN 119
CW	109	504	ZIN 109
CW	110		GER 002 (5)
CW	111	673	TIN 001
CW	112	1372	GSC 008 (1)
CW	112	1546	ZIN 109
CW	113	2300	GER 002 (6, 2)
CW	113	2855	GER 002 (6, 9)
CW	114	3379	GER 002 (2, g)
CW	114	2625	GER 002 (7, 2)
CW	114	3477	ZOU 001 (G)
CW	114	2799	ZOU 002
CW	115		GER 002 (3, 5)
CW	116	450	FJJ 004
CW	117	1813	GER 001.4 (150)
CW	118	3278	GER 002 (107, s)
CW	118	3185	GER 002 (46, s)
CW	118	2551	GER 002 (2, 56)
CW	118	3324	GER 002 (121, s)
CW	119	2350	GER 002 (6, 10)
CW	119	807	GER 001.4 (19)
CW	120	3851	GRE 001 (A)

	Type	CMD no.	Context
CW	121	2009	CHA 001
CW	121	919	GER 002 (g)
CW	122	3155	GER 002 (30, s)
CW	123	2521	GER 002 (2, 55)
CW	124	2010	GER 002 (g)
CW	125	3104	GER 002 (3, s)
CW	125	314	GER 002 (4, 2/1)
CW	125	2353	GER 002 (6, 10)
CW	125	3331	GER 002 (130, s)
CW	126	3198	GER 002 (52, s)
CW	127	917	GER 002 (g)
CW	128	3788	RUG 003
CW	129	2897	GER 002 (4, 48)
CW	130	4206	FUG 009
CW	131	2711	TIN 001
CW	132	3623	TIN 001 (BE)
CW	133	4173	TWE 002 (b)
CW	134	1331	GSC 002
CW	135	1934	GER 003 (106)
CW	136	932	GER 002 (1, 3)
CW	137	3156	GER 002 (30, s)
CW	137	169	GER 002 (3, 3/1)
CW	137	3350	GER 002 (8, 1)
CW	137	3172	GER 002 (42)
CW	137	3197	GER 002 (52, s)
CW	137	3271	GER 002 (63, s)
CW	137	2995	GER 002 (g)
CW	137	3531	ZOU 002
CW	138	2808	GER 002 (2, 73)
CW	138	2803	GER 002 (6, 21)
CW	138	3202	GER 002 (53, s)
CW	139	2947	GER 002 (4, 65)
CW	139	806	GER 001.4 (19)
CW	140	2900	GER 002 (2, 76)
CW	141	949	GER 002 (3, 5)
CW	142	2815	GER 002 (2, 86)
CW	142	2614	GER 002 (4, 92)
CW	143	2211	GER 002 (7, 2)
CW	143	3176	GER 002 (44, s)

	Type	CMD no.	Context
CW	144	3241	GER 002 (61, s)
CW	144	2730	GER 002 (g)
CW	145	3199	GER 002 (52, s)
CW	145	3343	GER 002
CW	145	848	GER 001.4 (16)
CW	145	1336	GSC 002
CW	146	133	ZIN 022 (South)
CW	147	3745	RUG 003
CW	148	1961	GER 003 (160)
CW	149	3164	GER 002 (33, s)
CW	149	3579	TIN 001 (B)
CW	150	2108	GER 003 (211)
CW	151	2904	CHA 001
CW	151		GER 002 (7, 77)
CW	151	1213	GSC 008
CW	156	1562	GSC 015
CW	157	2319	GER 002 (6, 2)
CW	158	451	FJJ 004
CW	159	1305	GSC 002
CW	160	1075	GSC 008
CW	161	1983	CHA 001
CW	161	2465	GER 002 (2, 33)
CW	162	3070	GER 002
CW	163	1850	GER 001.3 (1)
CW	164	3256	GER 002 (69, s)
CW	165	3686	TIN 001 (B)
CW	166	1055	GSC 008
CW	166	3687	TIN 001 (B)
CW	167	4184	GSC 020
CW	168	1223	GSC 008
CW	169	2089	GER 001.4 (211)
CW	170	597	ZIN 109 (10)
CW	171	3150	GER 002 (29, s)
CW	171	3207	GER 002 (54, s)
CW	171.1	2084	GER 001.5/6/7
CW	172	3969	GER 001.5/6/7
CW	173	3292	GER 002 (112, s)
CW	173	3103	GER 002 (3, s)
CW	173	3252	GER 002 (63, s)

	Type	CMD no.	Context
CW	173	3194	GER 002 (51, s)
CW	174	1823	GER 001.3 (15)
CW	175	947	GER 002 (2, 5)
CW	175	3873	GRE 001
CW	176	2426	GER 002 (4, 49)
CW	176	2227	GER 002 (7, 2)
CW	177	2824	GER 002 (6, 24)
CW	178		GER 002 (D, g)
CW	178	3967	GER 001.5/6/7
CW	179	3151	GER 002 (29, s)
CW	179	299	GER 002 (1, 4)
CW	179	3190	GER 002 (48, s)
CW	179	3229	GER 002 (59, s)
CW	179	2996	GER 002 (g)
CW	179	912	GER 002 (g)
CW	179	3233	GER 002 (60 s)
CW	179	2852	GER 002 (6, 9)
CW	179	1341	GSC 002
CW	179	1164	GSC 003
CW	179.1	422	GER 001 (5)
CW	180	3563	GBD 001
CW	180	2419	GER 002 (4, 18)
CW	180	971	GER 002 (4, 4/1)
CW	180	2204	GER 002 (6, 1)
CW	180	249	GER 002 (4, s)
CW	180	3188	GER 002 (118, s)
CW	180	2732	GER 002 (g)
CW	181	2209	GER 002 (4, 10)
CW	181	2658	GER 002 (6, 9)
CW	181	2491	GER 002 (2, 29)
CW	181	2208	GER 002 (4, 10)
CW	182	938	GER 002 (1, 2)
CW	182	2657	GER 002 (6, 9)
CW	182	2264	GER 002 (4, 11)
CW	182	2770	GER 002 (6, 24)
CW	182	2633	GER 002 (6, 12)
CW	183	2980	GER 002 (7, 29)
CW	183	2882	GER 002 (6, 24)
CW	183	4199	TWE 015

	Type	CMD no.	Context
CW	184	2802	GER 002 (6, 23)
CW	185	3158	GER 002 (30, s)
CW	186	3203	GER 002 (54, s)
CW	187	3162	GER 002 (32, s)
CW	188	2200	GER 002 (4, 10)
CW	189	3127	GER 002 (24, s)
CW	190	2280	GER 002 (6, 4)
CW	191	928	GER 002 (1, 2)
CW	191	965	GER 002 (4, 4/1)
CW	192	2823	GER 002 (4, 74)
CW	193	297	GER 002 (4, 2/2)
CW	193	3235	GER 002 (60, s)
CW	193	2011	GER 002 (g)
CW	194	953	GER 002 (4, 4/1)
CW	194	3139	GER 002 (28, s)
CW	194	2032	GER 001.4 (24, 1)
CW	195	842	GER 001.4 (8)
CW	196	3611	TIN 001 (B)
CW	196	3709	TIN 001 (B)
CW	197	3684	TIN 001 (B)
CW	198	604	ZIN 109 (11)
CW	199	578	ZIN 109
CW	200	1551	ZIN 109 (G)
CW	201	3817	LEK 009 (G)
CW	202	242	GER 002 (4, 5/4)
CW	203	2475	GER 002 (6, 14)
CW	204	3041	CHA 001
CW	204		GER 002 (2, 2)
CW	204	[H14]	GER 011 (T A3.3)
CW	204	[H188]	GER 011 (T A3.3)
CW	205		GRE 001
CW	206	608	ZIN 109 (4)
CW	207	1079	GSC 008
CW	208	1286	GSC 008
CW	209	4018	LEK 006
CW	210	3611	TIN 001 (BE)
CW	211	1729	FJJ 004
CW	211	3013	FJJ 004
CW	212	3685	TIN 001 (B)

	Type	CMD no.	Context
CW	213	1896	GER 001.3 (1)
CW	214	1944	GER 003 (152)
CW	215	399	GER 001.4 (12)
CW	216	2001	GER 003 (200)
CW	216	[H51]	GER 011(T A3.1)
CW	216	463	UAT 016
CW	216	1296	ZIN 115 (S)
CW	216	1091	ZIN 220 (g)
CW	216	236	ZIN 001 (s)
CW	217	288	ZIN 296
CW	217	2560	GER 002 (6, 18)
CW	218	6004	GER 001.3
CW	218	6040	GER 001.3
CW	218	6029	GER 001.3
CW	218	6037	GER 001.3
CW	218	6033	TIN 001 (B, 17, s)
CW	218.1	1192	GSC 004
CW	218.1	4198	TWE 011
CW	218.1	619	ZIN 109 (11)
CW	219	3374	GER 002 (4, 120)
CW	219	4197	TWE 011
CW	220	1984	CHA 001
CW	220	1994	CHA 001 (G)
CW	220		FJJ 006
CW	220	3006	FJJ 006
CW	220	1151	GSC 002
CW	220	1159	GSC 002 (G)
CW	220	1313	GSC 005 (g)
CW	220	2232	GER 002
CW	220	677	ZIN 001-003
CW	221	3818	LEK 009 (G)
CW	221	3712	TIN 001 (B, 5)
CW	221	3711	TIN 001 (B, Y)
CW	221	6031	TIN 001 (B, Y)
CW	222	3048	FUG 004
CW	222	[H43]	GER 011 (T A2.1)
CW	222	[H44]	GER 011 (T A2.2)
CW	222	[H21]	GER 011 (T A2.4)
CW	223	3492	ZOU 006

	Type	CMD no.	Context
CW	224	3727	RUG area
CW	225	3354	GER 002 (8, 10)
CW	226	3558	GEL 004
CW	226	2526	GER 002 (4, 120)
CW	226	3666	TIN 001 (A, 103, s)
CW	227	3542	ZOU 002
CW	228	6036	GER 001.3
CW	228		TIN 001 (A)
CW	228	3653	TIN 001 (A, 23, s)
CW	229	3694	TIN 001 (B)
CW	230	3816	LEK 009
CW	230	4198	TWE 011
CW	231	3473	ZOU 001
CW	231	3483	ZOU 002
CW	231	3540	ZOU 002 (G)
CW	232	3507	ZOU 004
CW	233	3491	ZOU 006
CW	234	3538	ZOU 002 (G)
CW	235	3725	RUG 001
CW	236	146	TAG 001
CW	236	3611	TIN 001 (BE)
CW	237	3820	LEK 009 (G)
CW	238	3539	ZOU 004
CW	239		GER 011 (T A2.4)
CW	239	429	ZIN 011 (30)
CW	240		GER 011 (T A2.2)
CW	240		GER 011 (T A2.2)
CW	240		GER 011 (T A2.3)
CW	240	572	ZIN 026 (N)
CW	240	279	ZIN 280 (S)
CW	241		GER 011 (T A2.3)
CW	242	3000	FJJ 002
CW	242	[H5]	GER 011 (T A2.1)
CW	242	[H46]	GER 011 (T A2.3)
CW	242	[H45]	GER 011 (T A2.3)
CW	242	4047	Jarma area
CW	242	[H202]	Jarma area/GER 011?
CW	243	3756	RUG area
CW	243	[H101]	GER 011 (T A2.2)

	Type	CMD no.	Context
CW	243	[H20]	GER 011 (T A2.4)
CW	243	[H97]	GER 011 (T A2.4)
CW	244	3826	LEK 009

Table 41.11. Distribution of Pottery Types in the Study Area: Handmade

	Type	CMD no.	Context
HM	301		ELH 005
HM	301		ELH 005
HM	301	3650	TIN 001 (A)
HM	301	1311	ZIN 001-003
HM	301	58	ZIN 013 (1)
HM	301	1251	ZIN 013 (110)
HM	301	1231	ZIN 013 (110)
HM	301	1133	ZIN 013 (32)
HM	301	260	ZIN 037 (1)
HM	302	3805	CHA 007
HM	302	95	ELH 006
HM	302	1480	ELH 003
HM	302	1470	FJJ 002
HM	302	1453	GER 002
HM	302	1235	GER 002 (4)
HM	302	104	GER 002 (G)
HM	302		GER 016
HM	302		GER 016:
HM	302	441	ZIN 001-003
HM	302	1228	ZIN 013 (108)
HM	302	426	ZIN 007
HM	302	53	ZIN 011 (10)
HM	302	1101	ZIN 013 (107)
HM	302	1242	ZIN 013 (36)
HM	302		ZIN 904
HM	302		ZIN 904
HM	302	1367	ZIN 001
HM	303	3776	CHA 005
HM	303		ELH 006
HM	303	1122	GBD 001
HM	303	57	GER 002 (2)
HM	303	499	ZIN 001-003
HM	303	1468	ZIN 001-003

	Type	CMD no.	Context
HM	303	1237	ZIN 011 (17)
HM	303	1172	ZIN 011 (24)
HM	303	116	ZIN 013 (u/s)
HM	304	3787	CHA 005
HM	304	3649	TIN 001
HM	304	55	ZIN 001-003
HM	304	4	ZIN 013
HM	304	1494	ZIN 060
HM	304	1243	ZIN 013 (109)
HM	304	1490	ZIN 060 (S0)
HM	305	1288	
HM	305	3416	CLF 008 (53, 3)
HM	305		ELH 005
HM	305	1469	GER 002 (5)
HM	305		GER 033
HM	305	2762	LAR 001
HM	305	3661	TIN 001 (A)
HM	305	3659	TIN 001 (A)
HM	305	472	TIN 001 (G)
HM	305	472	TWE 004?
HM	305	1486	ZIN 001-003
HM	305	223	ZIN 001-003
HM	305		ZIN 001-003
HM	305	136	ZIN 047 (S)
HM	305	1289	ZIN 070 (1)
HM	305	1462	ZIN 060 (5)
HM	305	99	ZIN 011 (20)
HM	305	67	ZIN 011 (26)
HM	305	1089	ZIN 013 (105)
HM	305	1185	ZIN 013 (35)
HM	305	1356	ZIN 013 (42)
HM	305	1211	ZIN 013 (108)
HM	305	26	ZIN 013 (4)
HM	305	1564	ZIN 101 (E)
HM	305	225	ZIN 001 (S)
HM	305	217	ZIN 001 (S)
HM	305	1062	ZIN 001 (S)
HM	305	59	ZOU 006
HM	306	1458	ZIN 051 (1)

	Type	CMD no.	Context
HM	306	1490	ZIN 060 (S0)
HM	307	3775	CHA 005
HM	307	3779	CHA 005
HM	307	3396	CLF 004
HM	307	1464	ELH 004
HM	307	31	GER 002 (G)
HM	307	1281	GER 002 (3, 2)
HM	308	3781	CHA 005
HM	308	1497	ELH 003
HM	308	3815	RUG 006
HM	308	1478	ZIN 060
HM	308	439	ZIN 001-003
HM	308	1077	ZIN 011
HM	308	1439	ZIN 001 (S)
HM	309	32	TAG 001
HM	310		EDU 018
HM	310	496	GER 001 (19)
HM	310	1428	ZIN 001-003
HM	310	1355	ZIN 013 (1)
HM	310	1047	ZIN 001 (S)
HM	310.1	3784	CHA 001
HM	310.1		MAR 009
HM	310.1	3669	TIN 001 (A)
HM	310.1	1454	ZIN 075
HM	311	4031	CLF 002
HM	311		ELH 006
HM	311	3707	TIN 001
HM	311	3635	TIN 001 (A)
HM	311	113	ZIN 011 (17)
HM	311	96	ZIN 011(20)
HM	311	1194	ZIN 013 (1)
HM	311	1081	ZIN 013(111)
HM	311	1144	ZIN 013 (32)
HM	311	1191	ZIN 013 (107)
HM	311	1246	ZIN 013 (109)
HM	311	1178	ZIN 013 (110)
HM	311	1245	ZIN 013 (111)
HM	311	1422	ZIN 013 (111)
HM	311	440	ZIN 034 (3)

	Type	CMD no.	Context
HM	311	485	ZIN 119
HM	312	1058	GSC 008
HM	313	1351	ZIN 013 (56)
HM	313	1227	ZIN 017 (38)
HM	314	1411	ZIN 013(39)
HM	315		ELH 006
HM	315		GRA 002
HM	315	1369	ZIN 011 (surface)
HM	315	1418	ZIN 013 (115)
HM	315	1319	ZIN 013 (29)
HM	315	1224	ZIN 013 (50)
HM	315	487	ZIN 119
HM	315	2	ZIN 013 (14)
HM	316		TWE 021
HM	316	3008	FJJ 006
HM	316	3014	FJJ 006
HM	317	4201	TWE 011
HM	317		ZIN 001-003
HM	317	1422	ZIN 001-003
HM	317	24	ZIN 001-003
HM	317	103	ZIN 001-003
HM	317	82	ZIN 001-003
HM	317		ZIN 118
HM	317	259	ZIN 001-003
HM	317	108	ZIN 013 (1)
HM	317	1097	ZIN 013 (107)
HM	318	2865	GER 002 (4, 74)
HM	318	2304	GER 002 (6, 2)
HM	318	2675	GER 002 (6, 21)
HM	318	2781	GER 002 (6, 23)
HM	319	2689	GER 002 (6, 21)
HM	319	2710	GER 002 (6, 21)
HM	320	3418	CLF 002
HM	320	3442	CLF 002
HM	320	2886	GER 002 (4, 110)
HM	320	3641	TIN (A, 12, 4)
HM	320	500	ZIN 109 (5)
HM	320	1254	ZIN 218 (3)
HM	321		CHA 001 (2)

	Type	CMD no.	Context
HM	321		GER 002
HM	321		GER 016
HM	321	497	ZIN 101 (2)
HM	322	1239	ZIN 218 (2)
HM	322	27	ZIN 011 (8)
HM	322	1105	ZIN 013 (103)
HM	322	1210	ZIN 013 (11)
HM	322	1186	ZIN 013 (108)
HM	322	1195	ZIN 013 (109)
HM	322	1197	ZIN 013 (111)
HM	322	431	ZIN 034 (4)
HM	323		CHA 026/027
HM	323		ELH 006
HM	323	1030	ZIN 013, (39)
HM	323	1093	ZIN 013 (107)
HM	323	1066	ZIN 013 (48)
HM	323	1429	ZIN 013 (50)
HM	324	1988	CHA 001
HM	324	3630	TIN 001
HM	324	1471	ZIN 060
HM	324	1466	ZIN 060 (4)
HM	324	61	ZIN 011 (10)
HM	324	1098	ZIN 013 (32)
HM	324	106	ZIN 013 (1)
HM	324	1238	ZIN 013 (108)
HM	324	1442	ZIN 013 (39)
HM	325	70	ZIN 011 (20)
HM	325	1104	ZIN 013 (7)
HM	325	1026	ZIN 013 (53)
HM	326	1092	ZIN 013 (103)
HM	326	434	ZIN 034 (4)
HM	326	1447	ZIN 060 (3)
HM	326	489	ZIN 119
HM	327	1118	ZIN 013 (106)
HM	327	1146	ZIN 013 (109)
HM	328	1260	GSC 003
HM	329	2646	GER 002 (4, 64)
HM	330		ELH 006 (2)
HM	330	1088	ZIN 013 (107)

	Type	CMD no.	Context
HM	331	3668	TIN 001
HM	331	4195	TWE 001? (5G)
HM	332	3563	GBD 001
HM	332	1443	ZIN 013 (5)
HM	333	1982	CHA 001
HM	333	1345	GSC 002
HM	333	1342	GSC 002
HM	333	1344	GSC 002
HM	333	1078	GSC 007
HM	333	1162	GSC 007
HM	333	668	ZIN 280
HM	333	559	ZIN 023 (5)
HM	333	563	ZIN 024
HM	333	505	ZIN 109
HM	333	560	ZIN 235
HM	333	655	ZIN 280
HM	333	666	ZIN 280
HM	333	656	ZIN 280 (G)
HM	333	674	ZIN 281
HM	333	1102	ZIN 330 (A)
HM	334	1970	CHA 001
HM	334	1995	CHA 001
HM	334	1964	CHA 001
HM	334	2030	CHA 001
HM	334	3448	CLF 008
HM	335	3422	CLF 002
HM	335	2416	GER 002 (4, 26)
HM	335	2278	GER 002 (4, 26)
HM	335	2859	GER 002 (7, 70)
HM	335	3856	GRE 001
HM	335	3836	GRE 001
HM	335	3847	GRE 001
HM	335	3857	GRE 001
HM	335	4020	LEK 007
HM	335	3741	RUG 003
HM	335	3754	RUG 003
HM	335		RUG 023
HM	335	3528	ZOU 002
HM	335	3486	ZOU 006

	Type	CMD no.	Context
HM	335	3458	ZOU 006
HM	335	3488	ZOU 006
HM	335	3520	ZOU 009
HM	335	3718	ZOU 011
HM	336	3518	Jarma area
HM	336	3439	Jarma area
HM	337	1974	CHA 001
HM	337		CHA 001
HM	337		ELH 005
HM	337		ELH 006
HM	337		ELH 006
HM	337		ELH 008
HM	337	3012	FJJ 006
HM	337	935	GER 002 (1, 4)
HM	337	931	GER 002 (1, 3)
HM	337	927	GER 002 (1, 3)
HM	337	2910	GER 002 (2, 76)
HM	337	2706	GER 002 (2, 76)
HM	337	2676	GER 002 (2, 76)
HM	337	2835	GER 002 (2, 27)
HM	337	2553	GER 002 (4, 88)
HM	337	966	GER 002 (4, 2/6)
HM	337	2895	GER 002 (4, 92)
HM	337	2831	GER 002 (6, 24)
HM	337	2461	GER 002 (6, 14)
HM	337	2488	GER 002 (6, 14)
HM	337	2598	GER 002 (6, 19)
HM	337	2887	GER 002 (6, 21)
HM	337	2784	GER 002 (6, 24)
HM	337	2806	GER 002 (6, 24)
HM	337	2355	GER 002 (7, 1)
HM	337	2772	GER 002 (7, 24)
HM	337	937	GER 002 (1, 4)
HM	337		GER 027
HM	337		GSC 006
HM	337		LEK 017
HM	337		RUG 021
HM	337	3654	TIN 001
HM	337	1432	ZIN 013 (39)

	Type	CMD no.	Context
HM	338		CHA 001
HM	338		GER 002
HM	338	933	GER 002 (1, 1)
HM	338	922	GER 002 (1, 4)
HM	338	930	GER 002 (1, 3)
HM	338	921	GER 002 (1, 4)
HM	338	2608	GER 002 (2, 67)
HM	338	2853	GER 002 (2, 67)
HM	338	2911	GER 002 (4, 101)
HM	338	2674	GER 002 (6, 21)
HM	338	2394	GER 002 (6, 10)
HM	338	2704	GER 002 (6, 19)
HM	338	2695	GER 002 (6, 21)
HM	338	2840	GER 002 (6, 24)
HM	338	2822	GER 002 (6, 24)
HM	338	2623	GER 002 (6, 9)
HM	338		GER 016
HM	338		RUG 022 (2)
HM	339		CHA 026
HM	339	2570	GER 002 (2, 67)
HM	339	2690	GER 002 (2, 77)
HM	339	2244	GER 002 (2, 13)
HM	339	2522	GER 002 (2, 57)
HM	339	2493	GER 002 (2, 57)
HM	339	2520	GER 002 (2, 57)
HM	339	2312	GER 002 (4, 26)
HM	339		GER 004
HM	339		GER 004
HM	340	2269	GER 002 (1, 1)
HM	340	2541	GER 002 (2, 57)
HM	340	2845	GER 002 (6, 24)
HM	340	2572	GER 002 (6, 9)
HM	340	3642	TWE area
HM	341	3638	TIN 001
HM	341	3655	TIN 001
HM	341	3673	TIN 001
HM	341	1099	ZIN 013
HM	342	2347	GER 002 (7, 2)
HM	342	2286	GER 002 (7, 2)

	Type	CMD no.	Context
HM	342	2399	GER 002 (4, 26)
HM	342	3700	TIN 001
HM	343		ELH 006
HM	343		ELH 005
HM	343	2531	GER 002 (2, 28)
HM	343	2313	GER 002 (2, 3)
HM	343	2438	GER 002 (2, 33)
HM	343	2562	GER 002 (2, 56)
HM	343	2235	GER 002 (4, 26)
HM	343	2311	GER 002 (4, 13)
HM	343	2266	GER 002 (4, 13)
HM	343	2386	GER 002 (4, 19)
HM	343	2348	GER 002 (4, 26)
HM	343	2400	GER 002 (4, 26)
HM	343		GER 016
HM	345		GBD 002
HM	345	2505	GER 002 (2, 38)
HM	345	2809	GER 002 (4, 100)
HM	345	2411	GER 002 (4, 26)
HM	345	2317	GER 002 (6, 2)
HM	345		GER 026
HM	345		ZOU 001
HM	345		ZOU 001
HM	346		BBA 015
HM	346		CHA 001
HM	346		CHA 001
HM	346	3017	FJJ 006
HM	346		GBD 021
HM	346		GEL 027
HM	346	2248	GER 002 (2, 11)
HM	346	2468	GER 002 (2, 33)
HM	346	2557	GER 002 (4, 65)
HM	346	2240	GER 002 (4, 26)
HM	346	2637	GER 002 (4, 30)
HM	346	2848	GER 002 (4, 24)
HM	346	2670	GER 002 (6, 9)
HM	346	2377	GER 002 (7, 1)
HM	346	2388	GER 002 (7, 2)
HM	347	3433	CLF 008

	Type	CMD no.	Context
HM	347	2851	GER 002 (4, 24)
HM	347	979	GER 002 (4, 1, 4-5)
HM	347	2358	GER 002 (4, 26)
HM	347	2662	GER 002 (6, 9)
HM	347		GER 004
HM	347	3848	GRE 001
HM	347		RUG 022
HM	347		ZOU 001
HM	347		ZUL 010
HM	348	331	FJJ 002
HM	348	493	ZIN 001-003
HM	348	3714	ZOU area
HM	349	3421	CLF 002
HM	349		FJJ 006
HM	349	3999	LEK 001
HM	349	3748	RUG 003
HM	349	3651	TIN 001
HM	350	3446	CLF 002
HM	350	3420	CLF 002
HM	350	3056	FUG 003
HM	350	3858	GRE 001 (176)
HM	351	3444	CLF 002
HM	351	3498	ZOU area
HM	351	3480	ZOU area
HM	352	3761	
HM	352	3384	CLF 002
HM	352		ELH 006
HM	352	1901	FUG 001
HM	352	4205	FUG 009
HM	352		GER 003
HM	352	4002	LEK 001
HM	352	3591	TIN 001
HM	352	1276	ZIN 087
HM	353	3387	CLF 002
HM	353	3389	CLF 002

	Type	CMD no.	Context
HM	353	1000	TWE 001
HM	354	3431	CLF 002
HM	354	4001	LEK 010
HM	355		GER 002
HM	355		GER 015
HM	355		GER 027
HM	355	3790	TAG 020
HM	355	427	ZIN 109 (12)
HM	355	671	ZIN 280 (1)
HM	356	3569	GBD 002 (26)
HM	356	3553	GEL 002
HM	356	3551	GEL 002
HM	356	4006	LEK 001
HM	357	3415	CLF 002
HM	357	3886	CLF 002
HM	357	3552	GEL 002
HM	358	3804	CHA 007 (S)
HM	358	3423	CLF 002
HM	358	3438	CLF 002
HM	358	3388	CLF 002
HM	358	3555	GEL 003
HM	358	1338	GSC 002
HM	358	3824	LEK 009
HM	358	3731	RUG 001
HM	358	3722	RUG 001 (G)
HM	358	432	ZIN 001-003
HM	358	495	ZIN 105 (5)
HM	359		CHA 031
HM	359		ELH 005
HM	359		ELH 006
HM	359	4204	FUG 009
HM	359	3558	GEL 004
HM	359	1101	ZIN 001-003
HM	360	1022	GSC 010 (SP)

PART B. FINEWARE

Black or Red Gloss of 'Hellenistic' Date

The following should be regarded as possible candidates for fineware status. They were not so identified in the original field notebooks but since they were all recovered from the surface they could well have lost most if not all of their slip coating. Essentially, attribution has been made solely on the basis of shape. It has not been possible to re-examine any of the vessels.

Type 501

CMD No.	Context	Other information
286	ZIN 291	No fabric description

See Morel 1981, series 2900, particularly 2951-2955 the majority of which Morel dates to the 2nd century BC. No. 2953a1 is from Tripoli (the Bab Bin Gascir necropolis, tomb 1).

Type 502

CMD No.	Context	Other information
273 [DZ 401]	ZIN 109 (13)	Hard red, self-coloured.

See Morel 1981, 2974a1, dated to the mid 2nd century BC.

Type 503

CMD No.	Context	Other information
3016	FJJ 002 (9)	No fabric description. Small imported bowl

Type 504

CMD No.	Context	Other information
1213	GSC 008 (1)	Liver red fabric with grey outside and in (traces of brown outside); hard, almost metallic

See Morel 1981, Series 2825. No. 2825d 1 is from Tripoli (the Bab Bin Gascir necropolis, tomb 3).

Type 505

CMD No.	Context	Other information
1839	UAT 004 (7)	No fabric description
332	FJJ 002 (6)	No fabric description. A little imported bowl
705	ZIN 296	No fabric description

CMD No.	Context	Other information
1350	GSC 008 (1)	No fabric description
2630	GER 002 (6, 9)	Fine red with black slip
3332	GER 002 (132, s)	Fine black, slipped
1966/ 1967	CHA 001	No fabric description
	GSC 016	No fabric description

See Morel 1981, Series 2787. Morel defines two production centres for the series, central Italy and Campania, dating the commencement of the former to the early 3rd century BC and that of the latter to about a century later. Our vessel is closer in form to the Campanian production (2787 f-h). No. 2787h is from Tripoli (Bab Bin Gascir Necropolis, tomb 3).

Type 506

CMD No.	Context	Other information
3010	FJJ 002 (13)	No fabric description.

Small imported bowl. There seem to be no close parallels in Morel.

Hellenistic White-ground Lagynos**Type 507**

CMD No.	Context	Other information
[H 42]	GER 011 (TA2.1)	Fine, pale, pinkish buff fabric, white slip ground. Seen in Jarma Museum.

The handle, the rim and much of the neck are missing. Decoration in dark brown paint: broad band at base of neck; broad band at angle of shoulder with two narrower bands above and one below; narrow band at the top of the footring; on shoulder, four wreaths with bows, dolphin, large wading bird, syrinx. Close parallels for this vessel are known from the Athenian Agora (Rotroff 1997, 225 ff.). The syrinx and the square-ended bow on catalogue nos. 1504 and 1521 are sufficiently close to those on our example as to suggest that the same hand painted them. At Athens these white-ground lagynoi were being imported in the first quarter of the 2nd century BC but were most popular between 150 and 50 BC (Rotroff 1997, 226-7). They occur all over the Mediterranean and originate from a number of sources though, at present none of these can be definitively identified.

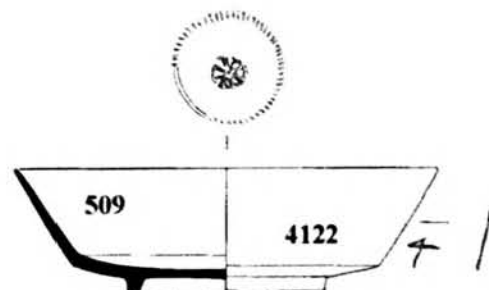
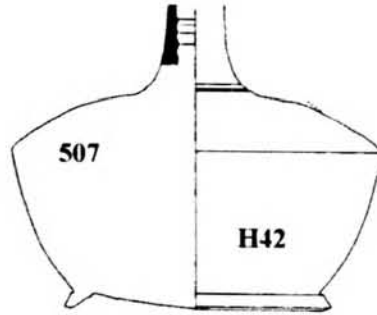
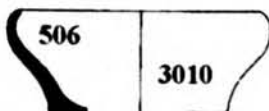
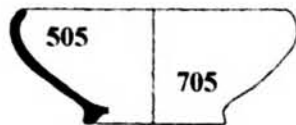
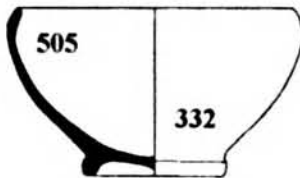
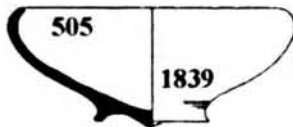
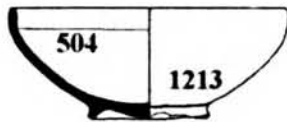
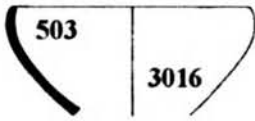
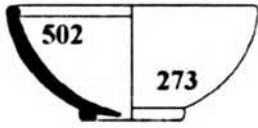
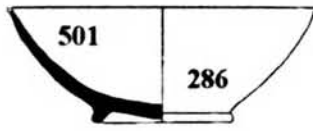

Figure 41.1. Fineware types 501-509. Drawings & upper photograph 1:4. Lower photograph 1:2 approx.

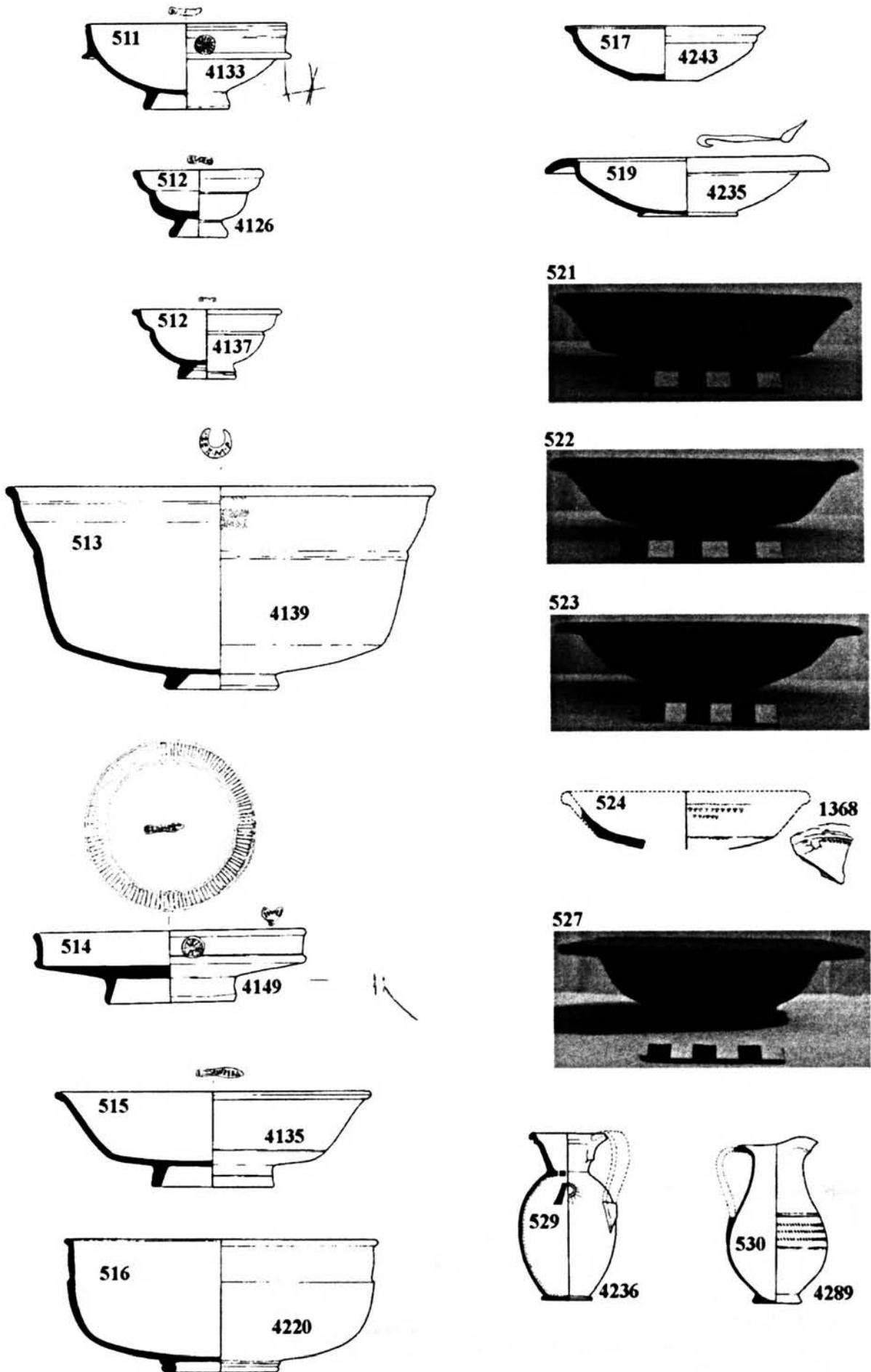

Figure 41.2. Fineware types 511-530. Drawings 1-4. Photographs 1-4 approx.

Eastern Sigillata A

Type 508

CMD No.	Context	Other information
4118	GER 011 (T 17AJ)	Rosette stamp

Atlante form 40A. c.AD 80-120. Hayes lists two other examples of this form from Jarma, both unstamped. The first (H80) is from another tomb at GER 011 (T 3C) (*Atlante*, 'Prototipi', A and Tav. V, no. 16); the findspot of the second (H94) (*Atlante*, 'altri esemplari') is unclear. AD 80-120.

Type 509

CMD No.	Context	Other information
4122	GER 011 (T 17AA)	Rosette stamp

Atlante form 40C. c.AD 80-120.

Type 510

CMD No.	Context	Other information
-	Jarma area	

An example of *Atlante* form 51 is also known from Jarma, though its precise findspot is unclear (*Atlante*, p. 37, under 'altri esemplari', and Tav. VI, no. 209). AD 70-120.

Italian Sigillata

Information on the stamps has been provided by Philip Kenrick.

References to potters from OCK are as follows: the number in front of the decimal point signifies the potter in the OCK listing; the number after the decimal point represents an individual die wherever possible. Where no type is indicated, the example is either too fragmentary to suggest an exact match or does not match exactly any type already in the catalogue.

Potters represented are as follows (Table 41.12).

Table 41.12. List of potters attested on Arretine stamps from Fazzân.

OCK no.	Potter's name	Place/date
612	Cornelius	Arezzo, c.AD 10 – 50+ (but stamps <i>in p. p.</i> should all be later than c.AD 15).
1210	Sex. M(urrius) Cal()	Pisa, c.AD 80 – 100+
1211	Sex. M(urrius) Cladus	Pisa, c.AD 80+

1212	Sex. M(urrius) Fes(tus)	Pisa, c.AD 60 – 150
1213	Sex. M(urrius) P()	Pisa, c.AD 60 – 150. Probably the same as the succeeding (rather than <i>Priscus</i> who also exists)
1214	Sex. M(urrius) Pi(sanus)	Pisa, late 1 st century – 1 st half of 2 nd century AD.
1690	L. Rasinius Pisanus	Pisa, active c.AD 50 – 120
2007	Sulpicius	Only two other examples known, from Chiusi and Ostia, reading SVLPPI[] and SVLPPI. Post c.AD 15 as the stamps are <i>in p. p.</i>

Type 511

CMD No.	Context	Other information
4133	GER 011 (T 17AB)	<i>in p. p.</i> , illegible (possible LRASINPIS)

Conspectus formarum 34.2 (Dr 24/25).

Type 512

CMD No.	Context	Other information
4126	GER 011 (T 17AL)	<i>in p. p.</i> , SVLPICI (OCK 2007)
4137	GER 011 (T 17AS)	illiterate. – This <i>may</i> be South Gaulish

Conspectus formarum 32 (Dr 27).

Type 513

CMD No.	Context	Other information
4100	GER 011 (T 15G)	lunate: SEXMVPI (OCK 1214.1)
4108	GER 011 (T 15F)	lunate: LRASINPIS (OCK 1690)
4123	GER 011 (T 17I)	<i>in p. p.</i> , SEX MF (OCK 1212)
4139	GER 011 (T 17J)	lunate, SEXMP (OCK 1213.35)

Dr 29.

Type 514

CMD No.	Context	Other information
4149	GER 011 (T 17AF)	SEX.M.P (OCK 1213.19)

Conspectus formarum 20.4. The most common form of Italian sigillata plate of the mid 1st century AD. It is still common at Pompeii and in Domitianic deposits at Ostia.

Type 515

CMD No.	Context	Other information
4116	GER 011 (T 17AU)	CORN ^A ELI (<i>in p. p.</i>) (OCK 612.12 or similar)
4119	GER 011 (T 17BG)	CORNE... (<i>in p. p.</i>) (OCK 612)
4136	GER 011 (T 17X)	CORN ^A ELI (<i>in p. p.</i>) (OCK 612.12 or similar)
4117	GER 011 (T 17Y)	CORN ^A ELI (<i>in p. p.</i>) (OCK 612.12 or similar)
4105	GER 011 (T 15K)	SMCAL (<i>in p. p.</i>) (OCK 1210)
4106	GER 011 (T 15L)	SMCAL (<i>in p. p.</i>) (OCK 1210)
4103	GER 011 (T 15N)	MCAL (<i>in p. p.</i>) (Kenrick seems to think this is M.N)
4113	GER 011 (T 17AH)	SEX.M.CL (<i>in p. p.</i>) (OCK 1211)
4124	GER 011 (T 17AZ)	SEXMCL (<i>in p. p.</i>) (OCK 1211)
4114	GER 011 (T 17K)	SEXMCL (<i>in p. p.</i>) (OCK 1211)
4253	GER 011 (T 42M)	SEXMCL (<i>in p. p.</i>) (OCK 1211)
4226	GER 011 (T 52K)	SEXMCL (<i>in p. p.</i>) (OCK 1211.5)
4225	GER 011 (T 52Q)	SEXMCL (<i>in p. p.</i>) (OCK 1211.5)
4110	GER 011 (T 17AI)	S...M...I (<i>in p. p.</i>) (OCK 1212 or 1213)
4138	GER 011 (T 17AQ)	SEX.M.F (<i>in p. p.</i>) (OCK 1212.16)
4132	GER 011 (T 17AR)	SEX.M.F (<i>in p. p.</i>) (OCK 1212)
4128	GER 011 (T 17AX)	SEX.M.F (<i>in p. p.</i>) (OCK 1212)
4125	GER 011 (T 17BE)	SEX.MF (or P) (<i>in p. p.</i>) (OCK 1212 or 1213)
4134	GER 011 (T 17AM)	SEX.MP (<i>in p. p.</i>) (OCK 1213.18)
4130	GER 011 (T 17BA)	SEX.M.P (<i>in p. p.</i>) (OCK 1213.14)
4127	GER 011 (T 17AQ)	RASINPIS (<i>in p. p.</i>) (OCK 1690)
4129	GER 011 (T 17AT)	LRASIN ^A IPIS (<i>in p. p.</i>) (OCK 1690)
4135	GER 011 (T 17S)	...PISAN (<i>in p. p.</i>) (OCK 1690, close to .11 or .12)
4227	GER 011 (T 52J)	LRASINPIS (lunate) (OCK 1690)
4228	GER 011 (T 52R)	...NPIS (<i>in p. p.</i>) (OCK 1690)

CMD No.	Context	Other information
4229	GER 011 (T 52S)	LRA...PISAN (lunate) (OCK 1690.55)
4111	GER 011 (T 17AV)	.I.I.VI. (<i>in p. p.</i>) (Kenrick notes the occurrence of similar stamps, also on form 3.2, in the stores at Lepcis Magna)
4115	GER 011 (T 17AW)	.I.I.VI. (<i>in p. p.</i>) as on 4111 and 4112
4112	GER 011 (T 17BF)	.I.I.VI. (<i>in p. p.</i>) as on 4111 and 4115
4120	GER 011 (T 17AC)	? (illiterate?)
4102	GER 011 (T 15H)	
4104	GER 011 (T 15M)	
4121	GER 011 (T 17AD)	
4131	GER 011 (T 17AN)	? (lunate)
1417	GER 001.3	

Conspectus formarum 3.2. 35 examples, almost all of them from tombs 17 and 15 at GER 011 (Sāniat bin Huwaydi).

South Gaulish

Type 516

CMD No.	Context	Other information
4220	GER 011 (T 52H)	

Dr. 37 (South Gaulish).

Glazed (Italian?)

Type 517

CMD No.	Context	Other information
4243	GER 011 (T 51H)	Sandy reddish-buff, thick, green lead-glaze

African Red Slip Ware

Type 518

CMD No.	Context	Other information
[H66]	GER 011 (T A2.1)	Hayes 1972, 19, no. 1

Hayes Form 2. Late 1st century AD. Not illustrated.

Type 519

CMD No.	Context	Other information
4101	GER 011 (T 150)	
4235	GER 011 (T 51S)	
	Other examples:	
[H64]	GER 011 (T A2.3)	Hayes 1972, 22-3, no. 20
[H67]	GER 011 (T A2.4)	Hayes 1972, 22-3, no. 23
[H68]	GER 011 (T A2.4)	Hayes 1972, 22-3, no. 24
[H69]	GER 011 (T A2.4)	Hayes 1972, 22-3, no. 25
[H70]	GER 011 (T A2.1)	Hayes 1972, 22-3, no. 26
[H27]	GER 011 (T A2.4)	Hayes 1972, 22-3, no. 27

Hayes Form 3b. Late 1st – Early 2nd century AD.

Type 520

CMD No.	Context	Other information
[H77]	GER 011 (T A2.3)	Hayes 1972, no. 88

Hayes Form 3c. Early-Mid 2nd century AD. Not illustrated.

Type 521

CMD No.	Context	Other information
[H30]	GER 011 (T A2.2)	Hayes 1972, 25, no. 4

Hayes Form 4, Late 1st-Early 2nd century AD.

Type 522

CMD No.	Context	Other information
[H71]	GER 011 (T A2.4)	Hayes 1972, 27, no. 14
[H32]	GER 011 (T A2.1)	Hayes 1972, no. 15

Hayes Form 5. Late 1st – Mid 2nd century AD.

Type 523

CMD No.	Context	Other information
	GER 011 (T A2.3)	Hayes 1972, 29, no. 13
[H33]	GER 011 (T A2.3)	Hayes 1972, 29, no. 14
[H72]	GER 011 (T A2.3)	Hayes 1972, 29, no. 15
[H73]	GER 011 (T A2.3)	Hayes 1972, 29, no. 2
[H74]	GER 011 (T A2.4)	Hayes 1972, 29, no. 3
[H75]	GER 011 (T A2.3)	Hayes 1972, 29, no. 4
[H76]	GER 011 (T A2.4)	Hayes 1972, 29, no. 5
[H96]	GER 011 (T A2.2)	Hayes 1972, 29, no. 6

Hayes Form 6. Late 1st – 2nd century AD.

Type 524

CMD No.	Context	Other information
1368	ZIN 119	Fragmentary, so possibly a Form 9
[H41]	GER 011 (T A2.3)	Hayes 1972, 33, no. 4

Hayes Form 8. Late 1st – 2nd century AD.

Type 525

CMD No.	Context	Other information
	GSC 030 (T 4)	Context noted by CMD; seen in Jarma museum in 2002; not included in Hayes 1972

Hayes Form 75 or 76. Mid 5th century AD.

Type 526

CMD No.	Context	Other information
	ZOU 002	Seen and catalogued by JND in 2000 after a re-examination of the material from this site

Hayes Form 84. 2nd half of 5th century AD.

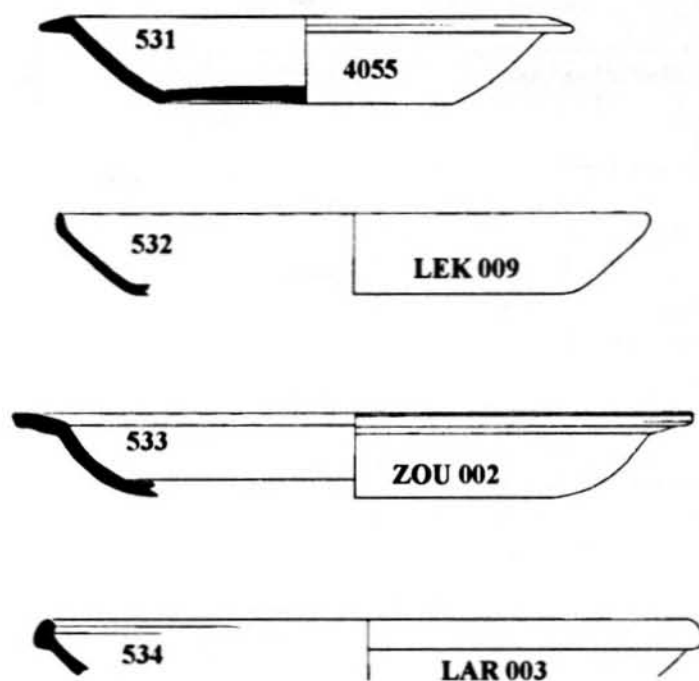

Figure 41.3. Fineware types 531-534. 1:4.

Type 527

CMD No.	Context	Other information
[H29]	GSC 030 (T 14)	Hayes 1972, Type 96, no. 7. Probably the example seen by Hayes in Sabhā Museum.

Hayes Form 96. Late 5th – Mid 6th century AD.

Type 528

CMD No.	Context	Other information
[H7]	Jarma area	Provenance not recorded. Hayes 1972, 173, no. 1
[H12]	Jarma area	Provenance not recorded. Hayes 1972, 173, no. 2

Hayes Form 121.1 – Spouted Jug or Feeder with Strainer. Late 1st – 2nd century AD.

Type 529

CMD No.	Context	Other information
4236	GER 011 (T 51T)	

Hayes Form 126.1 – Spouted Jug or Feeder with Strainer. 2nd century?

Type 530

CMD No.	Context	Other information
4289	GER 011 (T 9F)	Hayes notes that there is a good deal of variation in the form. Our example is closest to that shown on Hayes 1972, Plate IVb.

Hayes Form 137: Small jug with single handle. Late 1st – Mid 2nd century or later.

Tripolitanian Red Slip

Type 531

CMD No.	Context	Other information
4055	GER 011 (T 14A)	
2353	GER 002 (6, 10)	Sandy dark red with a dark red slip on its outer surface
[H24 & H26]	GSC 030 (T 3)	Hayes 1972, 305

Hayes Form 2. Late 3rd – 4th century AD. See also Coarseware type 125.

Type 532

CMD No.	Context	Other information
	LEK 009	
[H93]	GER 011	Hayes 1972, 308: 'Variant with heavy knobbed rim'.
[H28]	GSC 030 (T 4)	Hayes 1972, p. 308

Hayes Form 3. 4th century AD +.

Type 533

CMD No.	Context	Other information
	ZOU 002	
[H37]	GER 011	Hayes 1972, 308

Hayes Form 4C. 5th century AD +.

Type 534

CMD No.	Context	Other information
	LAR 003	

Hayes Form 8. 6th century AD +.

PART C. AMPHORAE

Types 1-5.1 (Late Punic – Early Roman)

Types 1-5.1 belong to a class of small (or at least not overly large) cylindrical amphorae (sometimes described as 'cigar-' or 'torpedo-shaped') originating from Tunisia and/or Tripolitania and produced, broadly speaking, between the 3rd to 1st centuries BC and the 1st century AD. Formal parallels can be found within Sabratha Types 7-9 (Dore and Keay 1989) and Van der Werff Forms 1-3 (Van der Werff 1978).

Van der Werff argues strongly (1978, 180) for a principal production centre for his Form 3 (the best equivalent for our types 1-5) in Tripolitania and certainly the fabric which has the strongest association with his form 3 is not dissimilar to that of our examples (1978, 173: *Categorie C: 'pâte de couleur allant de orange rouge à la couleur brique. Des zones foncées – gris ou brun-gris – sont fréquent dans la pâte'*).

Van der Werff regards his form 3 as established by the end of the 3rd century BC and its production (though not its exportation) continuing into the 1st century AD. Its occurrence at Sabratha (Sabratha Type 7) is broadly in agreement with this. In the Casa Brogan a single example of the form occurs in a level of period I which is thought to have begun towards the end of the 4th century BC and to span the 3rd century BC (context xiv, 54; Dore and Keay 1989, 275). In Regio II, Insula 6 the form occurs in quantity in a sequence which dates to the 2nd century BC (contexts xxi 14-17, Dore and Keay 1989, 285). On the north side of the East Forum Temple temenos and portico the form occurs in a pre-Tiberian sequence which is likely to start in the 3rd century BC (context i 43; Dore and Keay 1989, 259), and in the Antonine Temple it is present in a pit group thought to have been deposited in the closing years of the 1st century BC (Kenrick 1986, 175-99).

Five whole or almost whole examples (three from tomb A and two from tomb B) occur in association with Greco-Italic types (see our Type 10) in tombs of Punic type at Mellita near Sabratha (Bisi 1970). Fineware from the tombs dates from the 3rd to the 1st centuries BC.

Type 5.1 is equivalent to Van der Werff's form 1 which was produced in the Carthage region and in Mauretania Tingitana and which had a much wider distribution in the western Mediterranean. It seems to have been established by the second half of the 2nd century BC with export coming to an end round about the Augustan period but production for more localised consumption continuing possibly into the 1st century AD (Van der Werff 1978, 176-7, 193).

There are no examples of these forms in the assemblage from the Tripolitanian pre-desert (published in Dore 1996).

Type 1. Late Punic

CMD No	Context	Other Information
3587	TIN 001 (BE, G)	

Type 2. Late Punic

CMD No	Context	Other Information
3647	TIN 001 (A, 18, S)	
3608	TIN 001 (BE, B)	

Type 3. Late Punic

CMD No	Context	Other Information
1071	GSC 008 (1)	

Type 4. Late Punic

CMD No	Context	Other Information
	GER 001 (G1, 802D)	
3595	TIN 001 (BE, A)	
3607	TIN 001 (BE, B)	
202	UAT 002 (1)	
538	UAT 002 (G)	

Type 5. Late Punic

CMD No	Context	Other Information
3697	TIN 001 (B, 17, S)	
3696	TIN 001 (B, 17, S)	

Type 5.1. Late Punic

CMD No	Context	Other Information
1103	ZIN 220	Fabric not known

Fabric (Types 1-5): Sandy dark brown or red-brown, often with grey core and dark surface, and a cream slip, sometimes with a pinkish tinge, over the outer surface. The inclusion suite is dominated by abundant, well-sorted, rounded quartz grains the main fraction

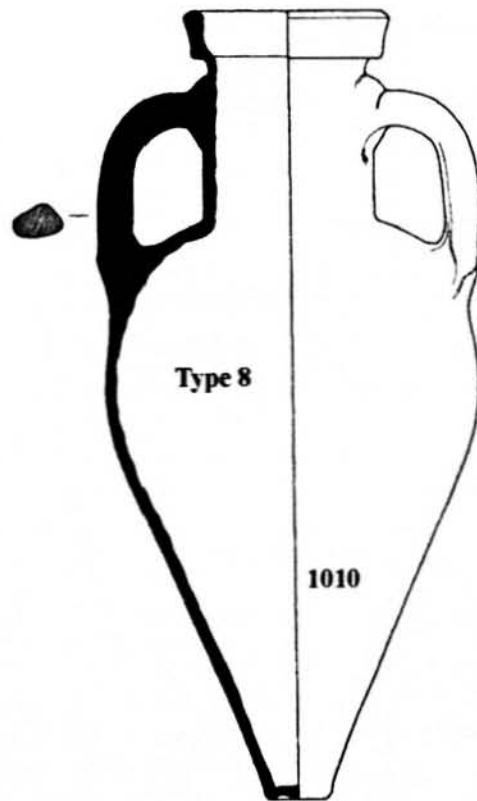
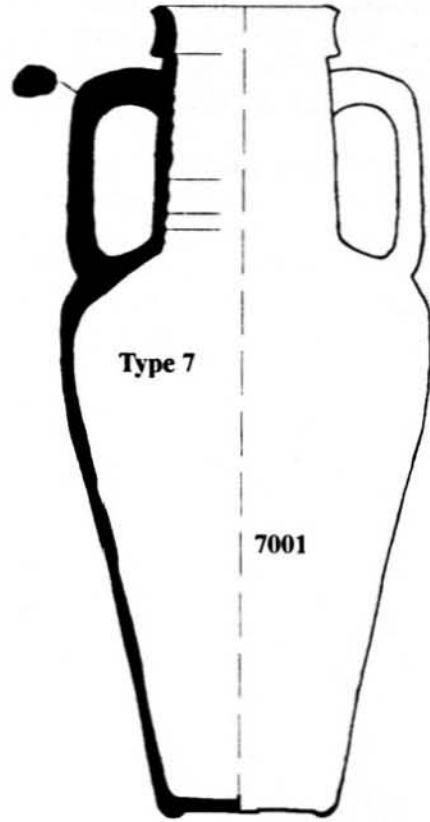
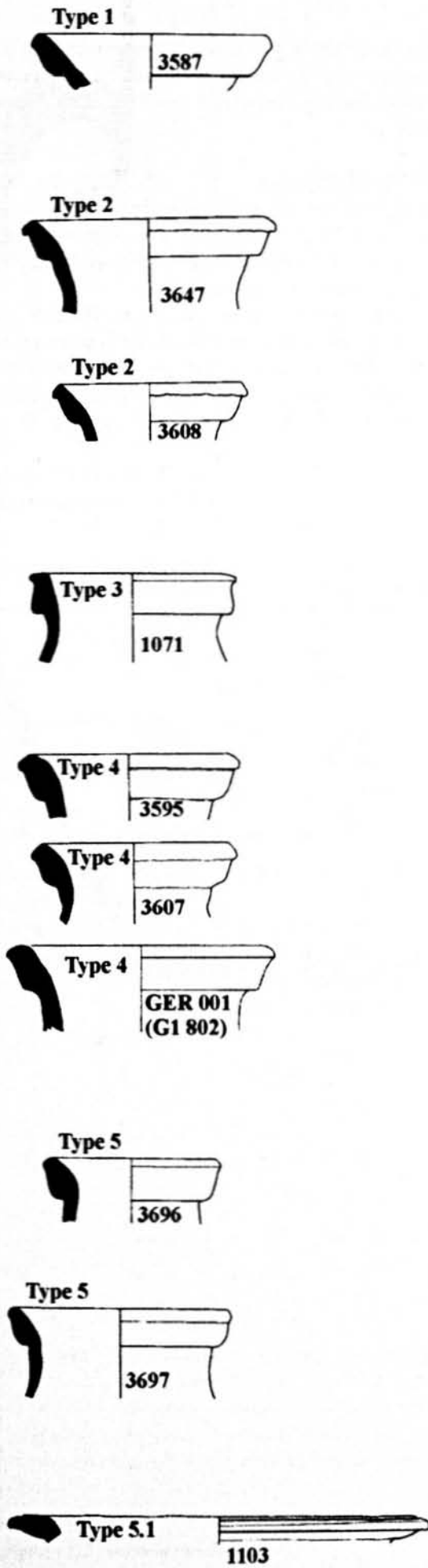

Figure 41.4. Amphora types 1-8. 1:4.

of which is sometimes quite fine, (grain diameter ≤ 0.1 mm), though mostly it tends to be somewhat coarser (grain diameter 0.2-0.3mm). Some examples also have a little lime and red or black iron-rich grains.

Types 6-8 – Small Amphoroid jars

While their rim shape clearly links them with the late Punic and early Roman Tripolitanian amphora series, it is difficult to be sure whether these were vessels for long distance transport of commodities or vessels of more domestic function. In default of a clear decision they have been termed 'amphoroid jars'.

Types 7 and 8 occur in the pre-desert area of Tripolitania (Dore 1996, Types 35 and 36) where their suggested date range is 1st-2nd century AD. Type 8 has been noted at Sabratha (Dore and Keay 1989, 49, no. 245) where it dates to the late 1st-early 2nd century AD. They have not been noted, to date, in the large assemblage of material seen by Dore at Leptiminus, and they may well, therefore, be an exclusively Tripolitanian product.

We have tentatively identified two of the jars in the catalogue as vessels currently on display in Jarma Museum.

Type 6. Small Amphoroid Jar

CMD No	Context	Other Information
7000	Jarma area?	On display in Jarma Museum, labeled 794.

Type 7. Small Amphoroid Jar

CMD No	Context	Other Information
7001	Jarma area?	

Type 8. Small Amphoroid Jar

CMD No	Context	Other Information
1010	GSC 002	On display in Jarma Museum, labeled 793.

Fabric: Sandy red-brown with yellowish-cream slip on the outer surface and the inside of the rim; inclusions: abundant, rounded quartz, 0.1-0.3mm, some lime 0.2-0.5mm.

Type 9. Amphoroid Jar

The walls of these vessels seem overly thin to have survived the exigencies of transport over any kind of distance and, as with types 6-8, there is thus some doubt as to whether they can be classed as amphorae.

At present we know of no parallels for the form of these vessels. Their fabric, however, is the same as a type of two-handled jug occurring in the pre-desert area (Dore 1996, Type 58) which has similarities to an early-Roman type at Berenice (Benghazi, Early Roman Jug 1; see Riley 1979).

Three examples are from the Sāniat bin Huwaydi cemetery. One example is from the recent excavations at Jarma (G1, 733, Phase 6/7).

CMD No	Context	Other Information
	GER 001 (G1, 733)	
4158	GER 011 (T 17G)	
4159	GER 011 (T 17H)	
4160	GER 011 (T 17F)	

Fabric: Sandy red-brown with dark grey to black outer surface. Inclusions: moderate or abundant rounded quartz, the main fraction of which is fine (ie grain diameter ≤ 0.1 mm), with occasional larger grains (up to 1.0mm); sparse rounded lime, mostly ≤ 0.2 mm, occasionally up to 1.1mm.

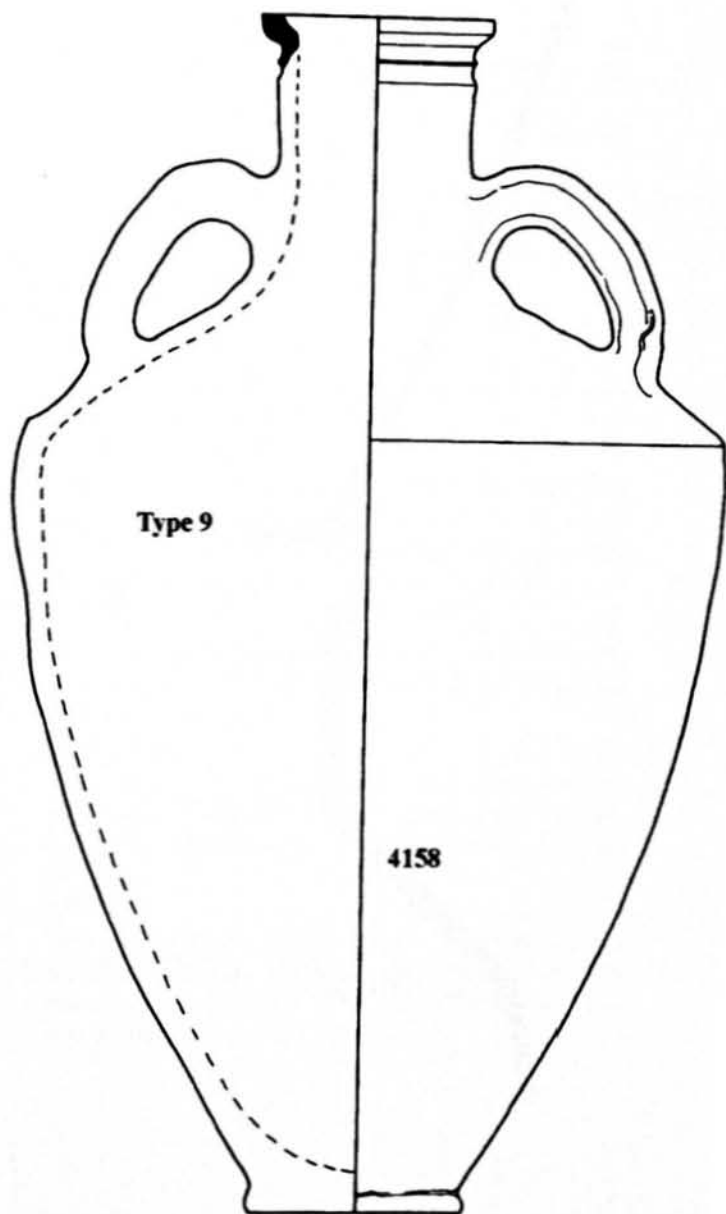
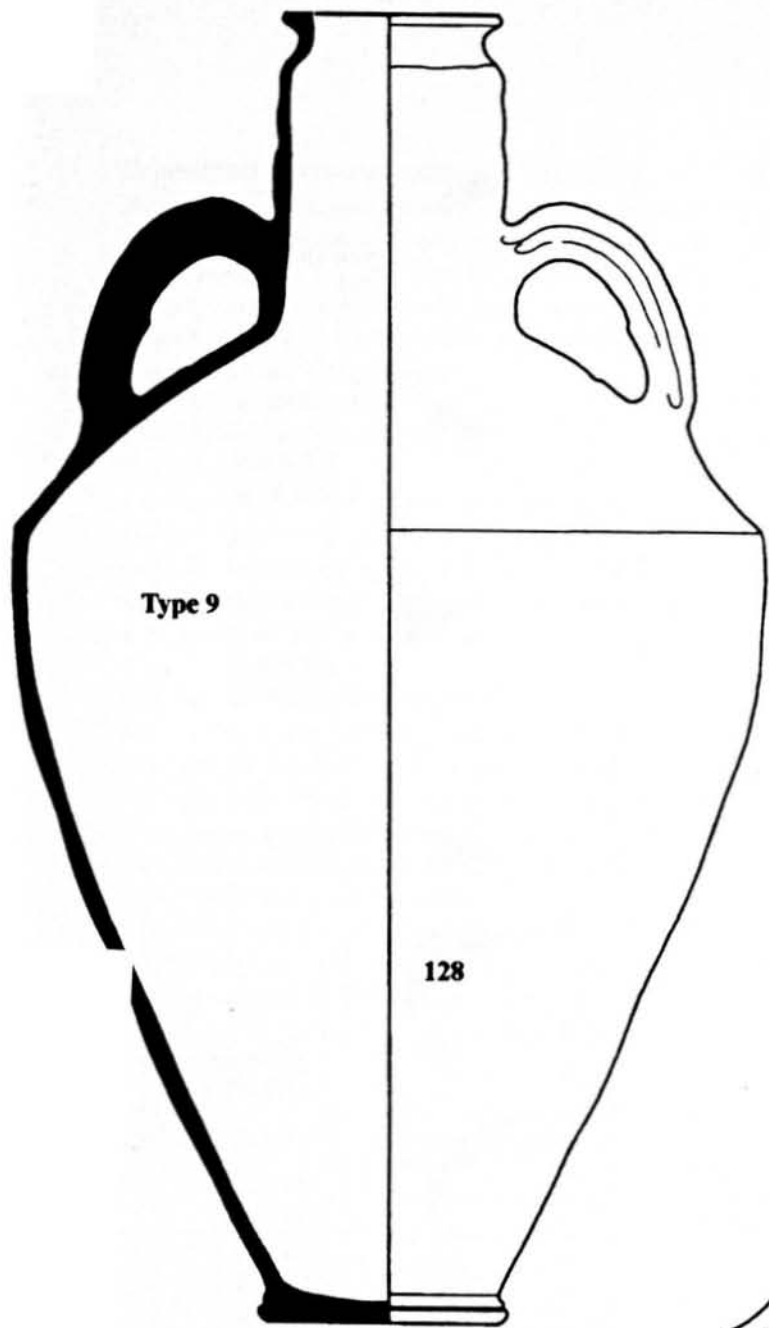

Figure 41.5. Amphora type 9. 1-4.

Types 10-12. Greco-Italic and Dressel 1

The morphological closeness between the later examples of Greco-Italic amphorae and early examples of the Dressel 1 type is well known, and it is, in any case, extremely difficult to differentiate between the types on the basis of rim sherds alone. We have split the examples from the Project area into three types:

Type 10: Probable Greco-Italic

Type 11: Probable Dressel 1a

Type 12: Dressel 1a

In Italy, production of the Greco-Italic type occupies the better part of the 3rd and 2nd centuries BC, being gradually supplanted during the last third of the 2nd century by the Dressel 1a type whose production lasts until the second half of the 1st century BC.

Type 10 - Probable Greco-Italic

The surviving fragments of GER 001 (G1, 950), in particular the handles and the lower body sherd which indicates a hollow basal spike rather than the solid variety of the Dressel 1, identify this vessel as a Greco-Italic type. The form of the rim fragment GER 001 (G1, 863) is very similar to it and its fabric is identical.

The forms of the rim fragments GER 001 (G1, 889), [3381] and [1542] can be paralleled by vessels of Greco-Italic type found in Tomb B at Mellita near Sabratha (Bisi 1970, fig. 9, no. 2, fig. 10, no. 6 and fig. 8, no. 3, respectively).

CMD No	Context	Other Information
	GER 001 (G1, 863)	Fabric 1
	GER 001 (G1, 889)	Fabric 2
	GER 001 (G1, 950)	Fabric 1
1542	GSC 017	
3381	GER 002 (2 G)	Fabric 1

Fabric: At least three fabrics can be distinguished:

1. GER 001 (G1, 863 and 950)

Sandy dull purplish pink, smoothed and slipped warm red-brown surfaces. Inclusions: abundant, rounded quartz, the main fraction of which is fine (grain diameter <=0.1mm), with occasional grains up to 0.4mm; moderate rounded lime, main fraction 0.1-0.2mm.

2. GER 001 (G1, 889)

Gritty orange brown, wet-slipped cream brown outer surface; a well fired, compact clay matrix with discrete inclusions: moderate rounded quartz, main fraction 0.2-0.4mm; moderate rounded lime, main fraction 0.2-0.3mm; moderate angular shell, main fraction 0.3-0.6mm; sparse rounded black grains, occasional max of 0.2mm.

3. GER 002 (2 G) [3381]

Gritty grey brown with a well defined orange core, dark grey to black surfaces; inclusions: abundant rounded quartz, main fraction 0.3-0.5mm, occasional max of 1.0mm.

Fabric 1 is certainly the same as that in which amphorae of Greco-Italic type occur in Punic tombs at Gargaresh (an example is on display in the Sarai al-Hamra (Department of Antiquities) in Tripoli and has been examined by Dore), and it may well be the same as those of some of the Greco-Italic amphorae at Mellita (those described as having 'argilla color camoscio', see Bisi 1970, 196, no. 2). At least one of these latter has a Punic stamp (the letters Kaf/Nun, Sad) at the base of one of its handles, and Bisi regards their production as local to Sabratha. Fabric 2 is very similar to one in which small amphorae of similar rim form to GER 001 (G1, 889) occur at Leptiminius on the central Tunisian coast (see Dore 1992, 132-3, Type 17). Fabric 3 may be the same as another of the fabrics occurring at Mellita (described as having 'argilla grigio-ferro con ingubbiatura biancastra', see Bisi 1970, 196, no. 4)

Type 11 Probable Dressel 1a

CMD No	Context	Other Information
1846	GER 001.3	Fabric 2
6041	GER 001.3	Fabric 2
3701	TIN 001 (B, 17, S)	Fabric 3
3704	TIN 001 (B, 21, S)	Fabric 3
3710	TIN 001 (B, 21, S)	Fabric 3
6035	TIN 001 (BE, B)	Fabric 1

Fabrics: The three fabrics recorded for the catalogued examples can be simply characterised as follows: 1. Sandy; 2. Sandy, lime rich; 3. Gritty. There is no indication from the inclusions that any of them derive from Italy.

1. (GW01)

Sandy dark grey; inclusions: abundant, rounded quartz, main fraction <=0.1mm, some 0.1-0.2mm, occasional max of 0.5mm

2. (BW04)

Sandy orange brown, cream slipped outer surface; inclusions: abundant, rounded quartz, main fraction <=0.1mm; abundant rounded lime, main fraction <=0.1mm

3. (CW02.1)

Gritty grey brown, grey surface with cream slip on outside; inclusions: abundant, well rounded quartz, main fraction <=0.2mm, some 0.3-0.5mm, occasional max of 3.5mm.

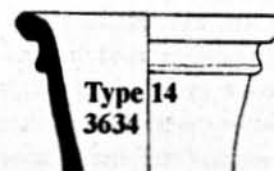
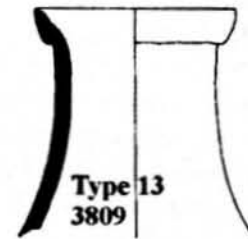
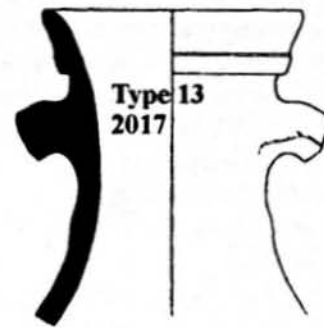
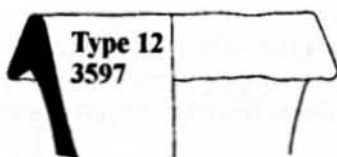
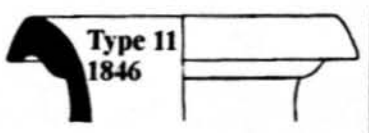
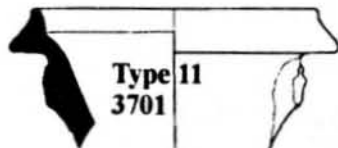
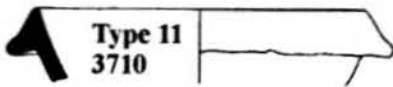
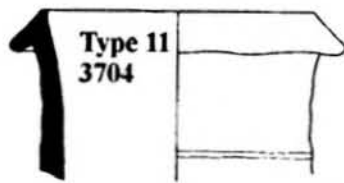
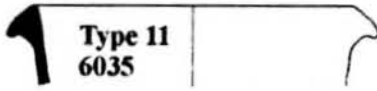
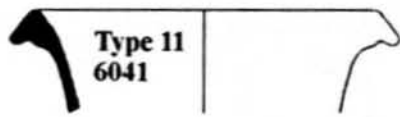

Figure 41.7. Amphora types 11-14. Drawings 1:4. Photograph 1:7 approx.

Type
12

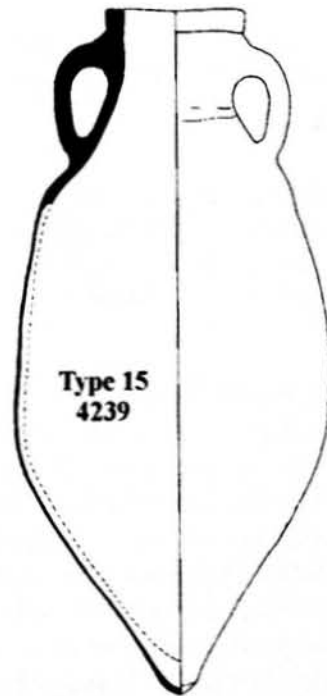
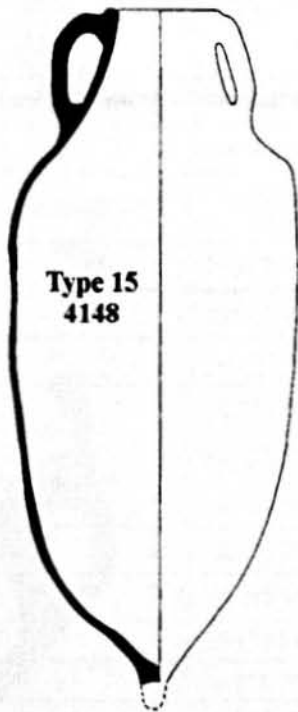
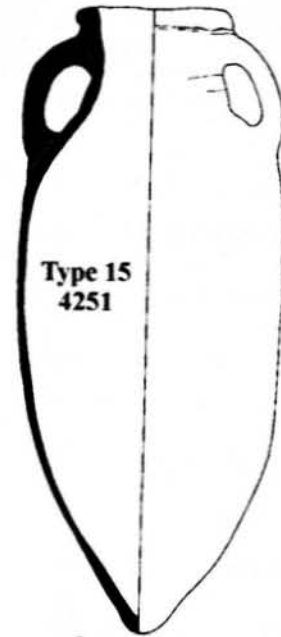
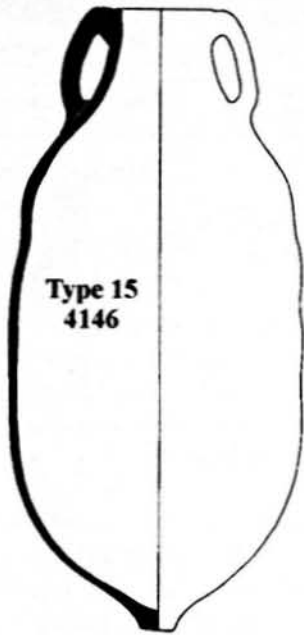

Figure 41.8. Amphora type 15. 1:8.

Dressel 1a

A single example.

CMD No	Context	Other Information
3597	TIN 001 (BE, A)	

Fabric: sandy grey

Type 13. Miscellaneous Hellenistic

Possibly related to type 10 (Greco-Italic). What may be a complete example is on display in Jarma Museum (exact provenance unknown). It is of generally similar size and shape to a Greco-Italic amphora but has horizontal strap handles on the shoulder. Its fabric suggests a North African origin. For another possible parallel see Riley 1979, fig. 72, no. 35, from Benghazi, classed as 'Miscellaneous Hellenistic'.

CMD No	Context	Other Information
2017	GER 001.3	Red fabric with lightly slipped red surface
3809	RUG 002	Brown fabric with white flecks; possibly a light slip on the outside, originally

Types 14 – 18. Early Roman**Type 14. Benghazi Early Roman Amphora Type 6**

An example of Benghazi Early Roman Amphora Type 6 (Riley 1979, 159). Late 1st century BC – early 2nd century AD.

CMD No	Context	Other Information
3634	TIN 001 (A2, 4)	

Fabric: Sandy dark grey with cream slipped surface; inclusions: abundant, rounded quartz, main fraction <=0.1mm, occasional max of 0.5mm; moderate rounded lime, main fraction 0.2-0.4mm, occasional max of 1.2mm.

Type 15. Early Roman Tripolitanian

A small to medium amphora with a capacity varying between c.17 and 29 litres (estimated using the same method as described for Type 19). It has an approximately ellipsoidal body with, in several examples, a poorly developed shoulder. The handles spring from the base of the neck and attach to the rim or just below it. The rim is generally poorly articulated, either simply thickened or with a barely developed flange. The pointed base is likewise almost plain in two examples and barely articulated into a small spike in the other examples. Altogether, the standard of manufacture is not high.

CMD No	Context	Other Information
4146	GER 011 (T 17A)	Graffito (Punic?). Estimated capacity 24.9 l
4148	GER 011 (T 17E)	Estimated capacity 29.6 l
4251	GER 011 (T 42E)	Estimated capacity 17.4 l
4239	GER 011 (T 52A)	Estimated capacity 28.4 l

Fabric: Sandy dark grey, orange brown core, greenish cream slip/wash on the outer surface. Inclusions: abundant, rounded quartz, main fraction <=0.2mm, occasional max of 0.5mm; moderate rounded lime, main fraction <=0.1mm-0.3mm.

All four examples are from site GER 011, the cemetery of Saniat bin Huwaydi. Example [4146] has an inscription which was incised on the body pre-firing. It is debatable whether it is Punic but it could possibly consist of the letters *aleph*, *ain*, *shin*, *nun*, reading from right to left (see Peckham 1968).

Type 16. Early Roman Tripolitanian

This is essentially a higher quality version of Type 15 in terms of standard of manufacture. Enough survives of example [4177] to suggest that the form of the body is the same and the rim form exhibits the flange of type 15.

The example recovered from GER 001 (G1, 764) shows clear signs of having been overfired: the rim is extremely distorted and the fabric is black with a 'cokey' and overcooked feel.

CMD No	Context	Other Information
1845	Jarma area	
	GER 001 (G1, 764)	Near waster
2029	GER 001	
1847	GER 001.3	
1833	GER 001.3	
1942	GER 001.3	
2026	GER 001.3	
2020	GER 001.3	
1940	GER 001.3	
3344	GER 011 (8, 1)	
3602	TIN 001 (BE)	
4183	TWE 002 (c)	
4177	TWE 002 (c)	
3534	ZOU 002	

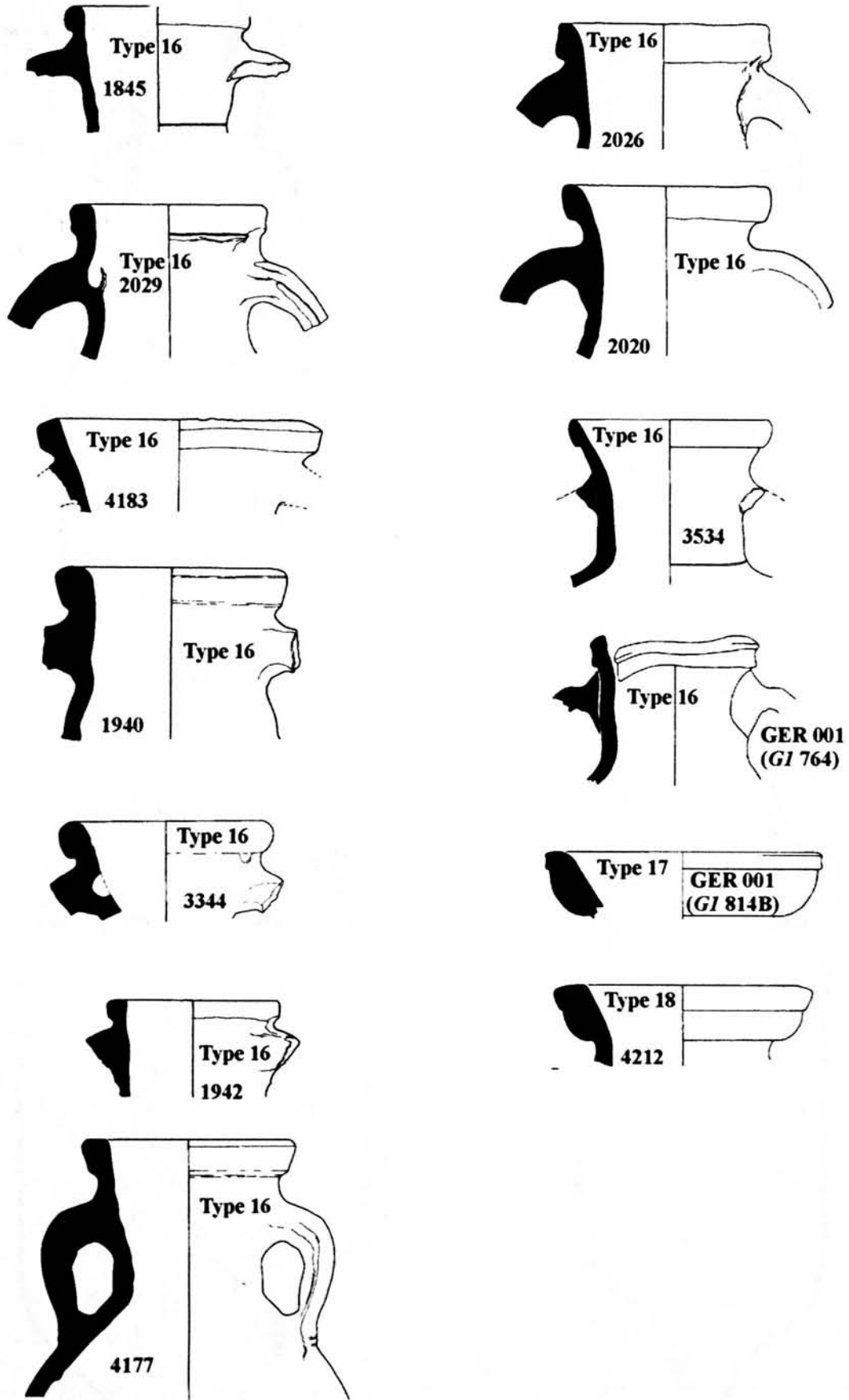

Figure 41.9. Amphora types 16-18. 1:4.

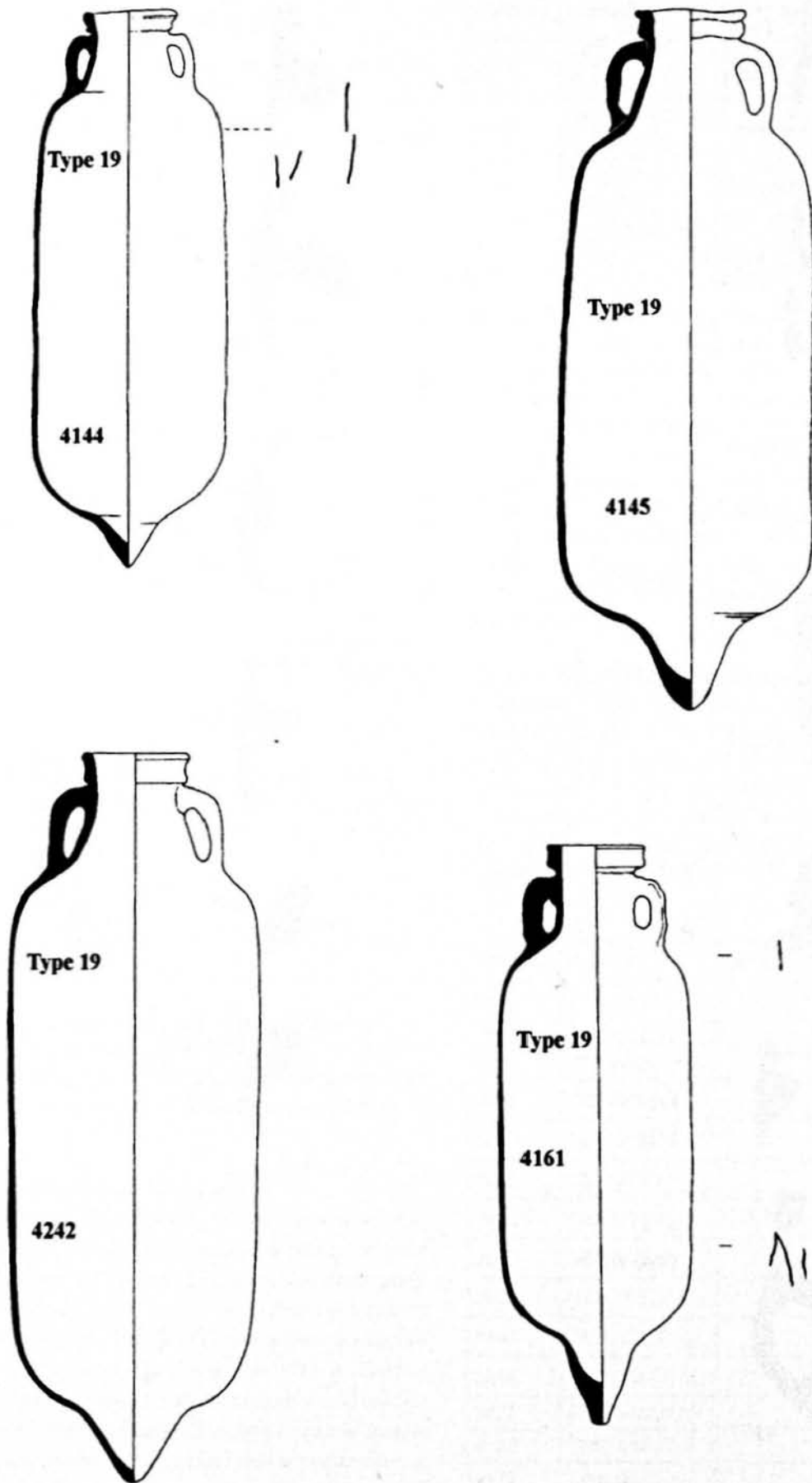

Figure 41.10. Amphora type 19. 1:8.

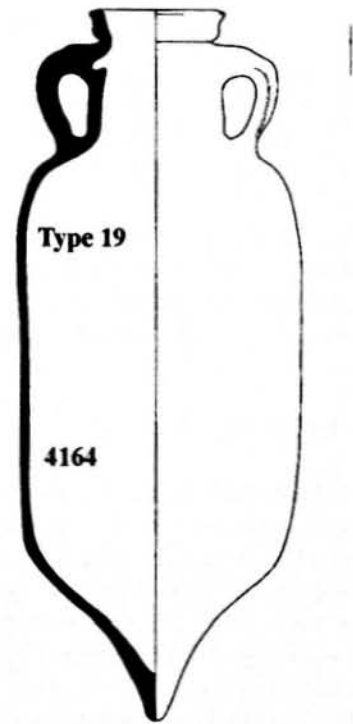
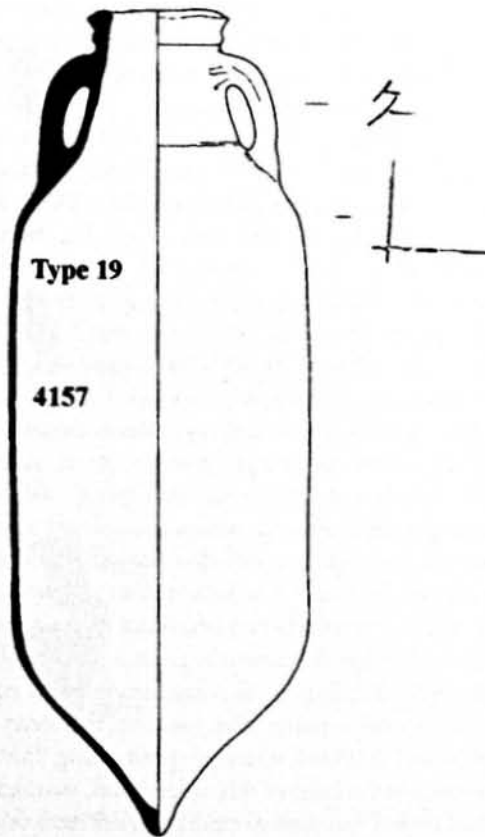
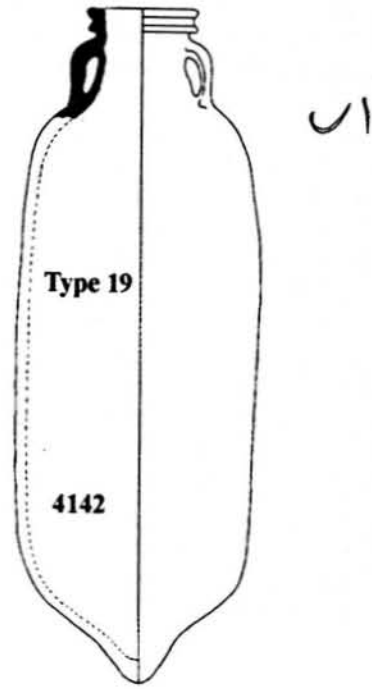
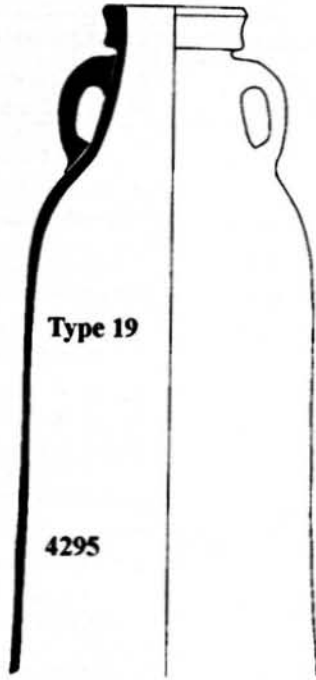

Figure 41.11. Amphora type 19 (cont). 1:8.

Types 17 and 18. Early Roman Tripolitanian

These two closely similar types seem to be formal representatives of the transition between types 1-5, 'Amphores de tradition punique' (Van der Werff 1978), which were current between the 3rd and late 1st centuries BC, and the Tripolitanian series as exemplified by Types 19 and 20 current from the late 1st century AD. They occur at Sabratha (where they are subsumed under a single type, 16b, see Dore and Keay 1989), most notably in Regio II Insula 10 (the Casa Brogan) beneath road surfaces broadly contemporary with period IIIb (late 1st century BC – mid 1st century AD), and at Berenice (where they are similarly subsumed under a single type, 11b) in a deposit (58) dated to the third quarter of the 1st century AD (Riley 1979). They are the earliest amphorae currently known in the Tripolitanian pre-desert (Dore 1996, 355, Type 1) where the start of the Roman ceramic series, on the basis of fineware, is thought to date to c. AD 50. Their distribution in central and southern Tunisia and Tripolitania points to a Tripolitanian production since they do not appear to occur in the published assemblage from the House with the Peristyle Mosaic at Uzita (Van der Werff 1982), and only one example is known from Leptiminus (unpublished).

Type 17

CMD No	Context	Other Information
	GER 001 (G1, 841B)	2002 drawing

Type 18

CMD No	Context	Other Information
4212	GER 011 (T 51S)	

Fabric: Sandy dark grey with cream coloured surfaces; inclusions: abundant, rounded quartz, main fraction ≤ 0.1 mm, occasional max of 0.5mm; moderate rounded lime, main fraction 0.2-0.4mm, occasional max of 1.2mm

Types 19-28 Mid-Roman**Type 19. Early-Mid Roman Tripolitanian**

There are ten examples of this type, all complete but one, and all deriving from tombs at GER 011 (Sāniat bin Huwaydi). The form is a small, cylindrical body with a hollow basal spike and a short neck topped by a rim with a moulding of double-stepped profile. There are two handles which attach at the neck, springing from immediately below the rim and the junction of the neck and the shoulder. A feature of [4164] and, to a lesser extent, [4142] is the pronounced indentation visible in the inner wall of the neck at the point where the handle joins

the neck, almost certainly made by the potter's finger when the handle was added. Two examples, [4145] and [4157], display quite pronounced distortion of the rim.

CMD No	Context	Other Information
4142	GER 011 (T 15A)	Marks on shoulder. Estimated capacity 20 l
4164	GER 011 (T 1A)	Estimated capacity 25.6 l
4145	GER 011 (T 17C)	Estimated capacity 42.5 l
4144	GER 011 (T 15B)	Marks on shoulder. Estimated capacity 18 l
4157	GER 011 (T 15C)	Marks on shoulder. Estimated capacity 36 l
4161	GER 011 (T 17B)	Marks on shoulder and lower wall. Estimated capacity 19.5 l
4248	GER 011 (T 42B)	Estimated capacity 20 l
4242	GER 011 (T 51V)	Estimated capacity 41.3 l
4241	GER 011 (T 52E)	Estimated capacity 20.5 l
4295	GER 011 (T 53A)	Estimated capacity not less than 33.5 l

Fabric: Sandy orange-brown or red-brown often much darker (dark purple) towards the external surface; usually with traces of a yellowish-cream slip on the external surface; inclusions: abundant, well rounded quartz, main fraction ≤ 0.2 mm; moderate sub-angular or rounded lime, main fraction ≤ 0.3 mm, though in some examples the grain size can be up to 1.0mm which gives the fabric a distinctive speckled appearance.

An estimate has been made, from the drawings, of the capacities of these vessels by modelling the internal space of each as a simple geometrical solid – a cylinder with a cone at either end, – and then computing the volume by means of the usual mathematical formulae. The results show that the sample of vessels can be divided into two groups, the first, which comprises vessels [4157], [4242] and [4145], having capacities of around 40 l, the second, which comprises vessels [4144], [4161], [4142], [4248] [4241] and [4164], having capacities of around 20 l. Table 41.13 sets out the data and gives the mean, standard error and standard deviation for each group. While caution must be exercised in extrapolating from such a small sample, we might, nevertheless, suggest that the observed variation in group 2 is greater than might be expected in a group of vessels manufactured to the same module (assuming that the capacities of such a group ought to be normally distributed, all other factors being equal). The vessel whose capacity diverges from the mean the most is [4164] at 25.6 l, which is approaching 2SD from the mean. On the basis of this observation, we might suggest that [4164] was manufactured to a different module, one around 25 l, rather than 20 l.

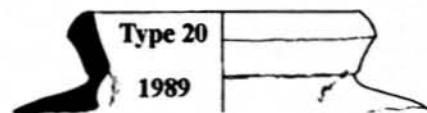
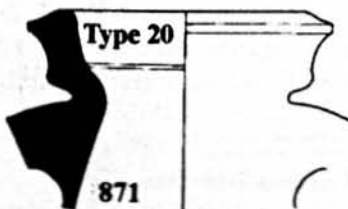
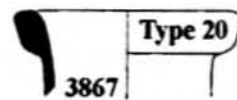
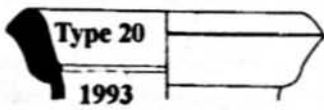
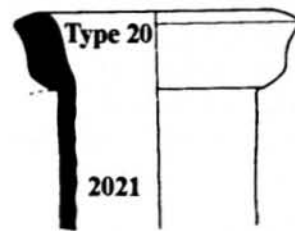
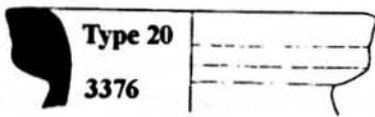
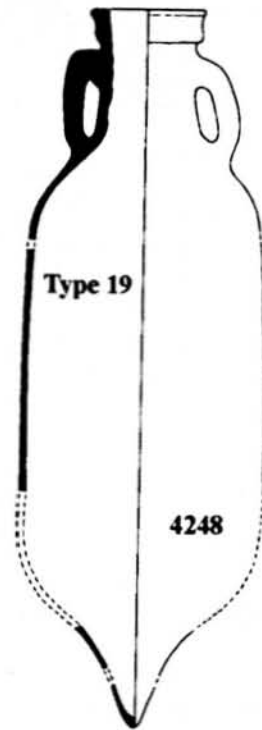
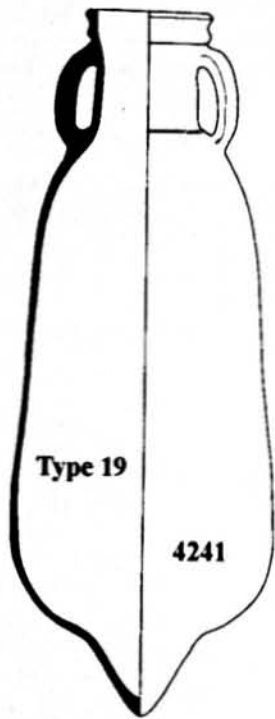

Figure 41.12. Amphora types 19 (cont.)-20. 1:8 (19), 1:4 (20).

Table 41.13. Type 19 Amphora Capacities (in litres)

	Group 1	Group 2
	36	18
	41.3	19.5
	42.5	20
		20
		20.5
		25.6
Mean	39.92	20.60
Standard Error	1.99	1.06
Standard Deviation	3.45	2.60

The fabric suggests a regional origin, almost certainly in Tripolitania, and the formal characteristics fall within the range which define Panella's Tripolitana I (Panella 1973), usually dated early 1st – mid 2nd century AD. The type was certainly made at a kiln site at Sidi al-Sid, on the edge of the Jabal Tarhuna to the south-west of Lepcis Magna (see Arthur 1982). The capacities of the examples from the Sāniat bin Huwaydi tombs are small in comparison to vessels known from the coastal sites and from Ostia. A vessel whose estimated capacity is approximately twice that of the group I vessels is known from a site in the pre-desert (el-Amud Site 4, see Dore 1984, 24), but since the estimate (c.105 l) was a maximal one made on the basis of the height of the filling spout in the room where it was found it is possible that the real capacity was less than the estimated. It seems likely, and obvious that a wide variety of capacities were available for the transport of commodities, the choice being governed by the economics of the transaction.

Type 20. Early-Mid Roman Tripolitanian?

Type 20 comprises miscellaneous rim and neck fragments which are probably from vessels of type 19 but which cannot be unequivocally assigned.

CMD No	Context	Other Information
871	Jarma area	
1989	CHA 001	
1993	CHA 001 (g)	
2022	GER 001	
3376	GER 002 (2, 4)	
2021	GER 001.4 (8)	
3867	GRE 001	

Fabric: Sandy brown or red-brown, often with redder core; yellowish cream slip on external surface; inclusions: abundant, rounded quartz, main fraction ≤ 0.2 mm;

moderate rounded lime, main fraction ≤ 0.1 mm, occasional max of 0.3mm.

Type 21. Mid Roman Tripolitanian

Type 21 comprises miscellaneous rim and neck fragments which are probably from vessels of Panella's types Tripolitana II or III, usually dated 2nd – 4th century AD, but which cannot be unequivocally assigned.

CMD No	Context	Other Information
1991	CHA 001 (g)	
1992	CHA 001 (g);	
2028	GER 001	
1677	GER 001 (5)	
3343	GER 002 (8,1)	Fabric 4
3371	GER 002 (4, 119)	Fabric 1
2782	GER 002 (7, 64)	Fabric 1
3377	GER 002 (g)	
829	GER 001.4 (11)	Fabric 2
1866	GER 001.4 (99)	Fabric 2
3612	TIN 001 (BE, B)	Fabric 3
4174	TWE 002 (B)	

Fabric: As is hardly surprising for a miscellaneous catch-all category like this, a number of fabrics are represented. All are well fired, and most are quite lime-rich but the fabric texture is very variable.

1. Fine, orange-brown to grey with a cream coloured slip on the external surface; inclusions: moderate, rounded lime, main fraction 0.1-0.5mm, a little 0.5-0.2mm.
2. Sandy mid brown to mid grey; inclusions: abundant, rounded lime, main fraction ≤ 0.1 mm, occasional max of 0.3mm; abundant rounded quartz, main fraction ≤ 0.1 mm, occasional max of 0.5mm; sparse, sub-angular, black iron-rich grains, occasional max of 0.5mm.
3. Sandy dark grey; inclusions: abundant, rounded quartz, main fraction ≤ 0.1 mm, some 0.1-0.2mm, occasional max of 0.5mm.
4. Gritty orange-brown to grey-brown with a dark grey core and a cream coloured slip on the external surface; a well fired, compact clay matrix with discrete inclusions: abundant, rounded quartz, main fraction 0.2-0.5mm; sparse, rounded lime, main fraction 0.2-0.3mm-0.1mm.

Type 22. Mid Roman Tripolitanian

There are two examples of this type, both complete, and both deriving from tombs at GER 011 (Sāniat bin Huwaydi). The form is a small ellipsoidal body with a conical neck which is barely articulated from the body, topped by an everted rim. There is a stubby basal

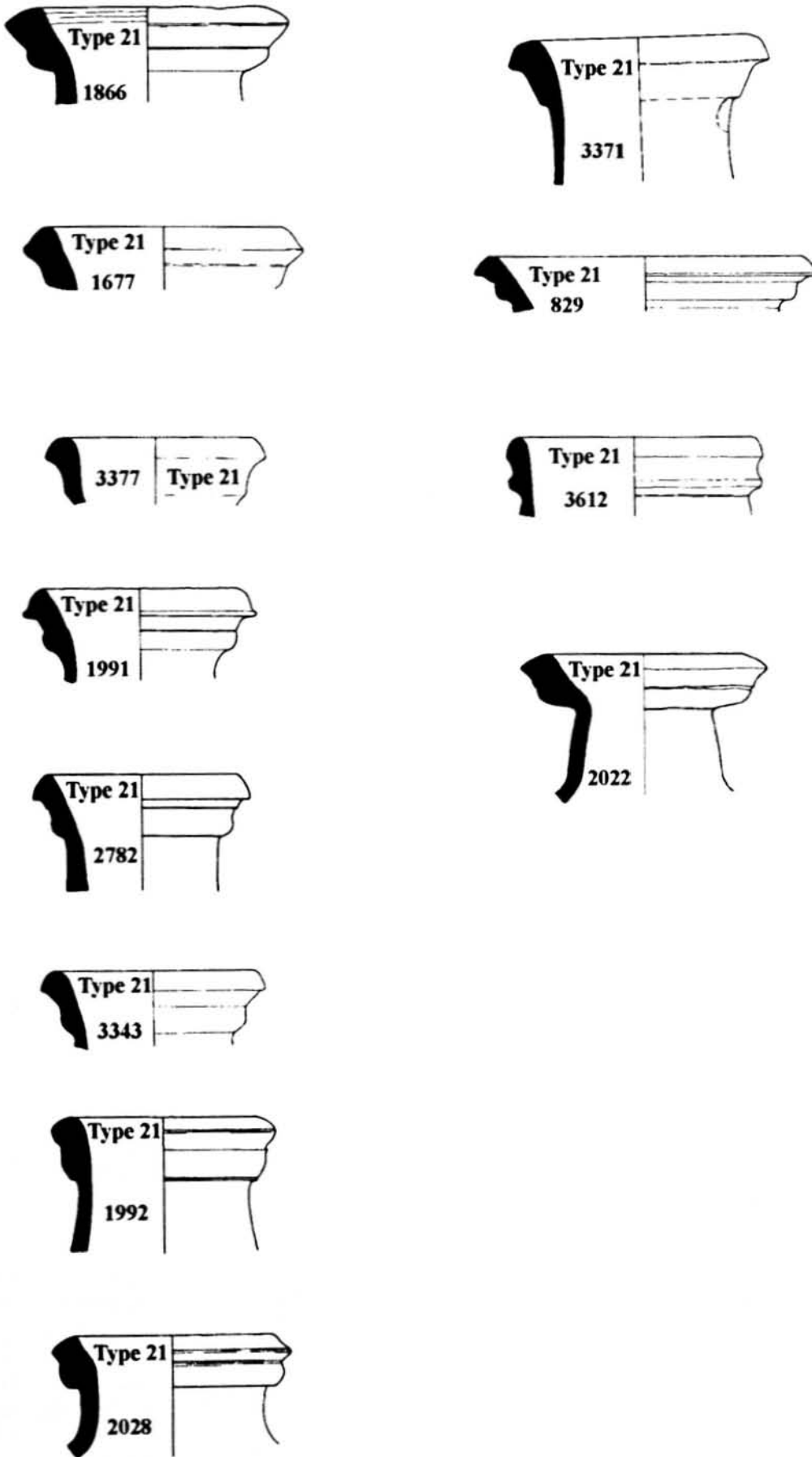

Figure 41.13. Amphora type 21. 1:4.

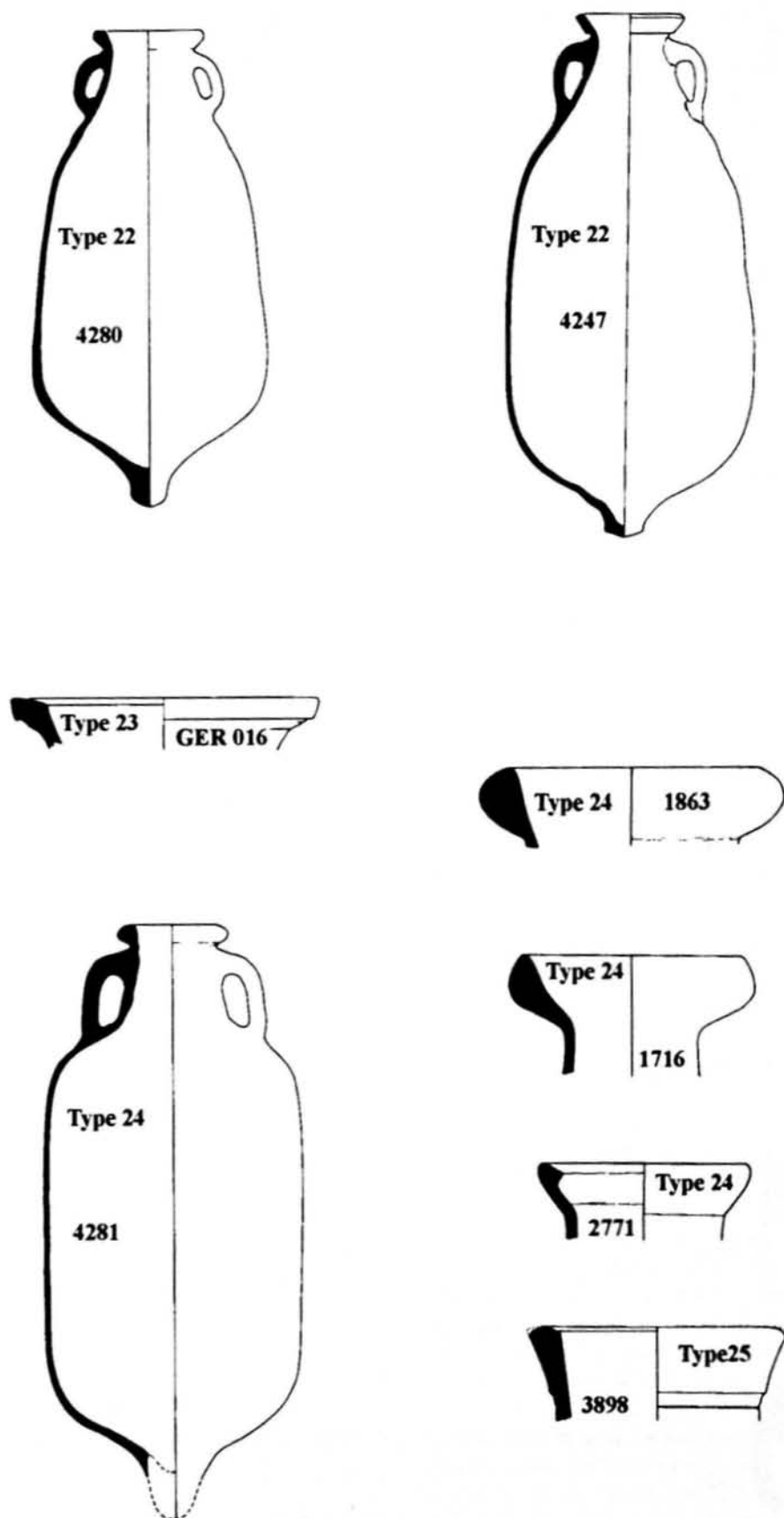

Figure 41.14. Amphora types 22-25. 1:4 (23, 24 except 4281, 25), 1:8 (22, 24.4281).

spike, hollow in [4247] and solid in [4280]. There are two handles which attach at the neck, springing from immediately below the rim and the lower neck. The capacities have been estimated using the same method as described for Type 19. The fabric cannot be differentiated from other Tripolitanian products though there are elements of the form, notably the rim of [4280] and the basal spikes which might be regarded as having greater affinities with the Tunisian 'Africana' series.

CMD No	Context	Other Information
4247	GER 011 (T 42A)	Est. capacity 22.6 l
4280	GER 011 (T 53H)	Est. capacity 15.5 l

Fabric: Well-fired, sandy, dark grey; inclusions: abundant, rounded quartz, main fraction ≤ 0.1 mm, some 0.1-0.2mm, occasional max of 0.5mm.

Type 23. Mid Roman Tunisian

This type, equivalent to Keay (1984) Type LIX, is now known to have been manufactured at Leptiminus on the central Tunisian coast, just to the south of modern Monastir. Examples were initially identified in material recovered from field survey at Leptiminus (Dore 1992, 133, no. 20), but since then the type has been found closely associated with kilns excavated in the late 1990s (Stirling and Ben Lazreg 2001; Stirling *et al.* 2000). 2nd – 4th century AD.

CMD No	Context	Other Information
	GER 016 (Grab)	
2764	LAR 002 (S)	

Fabric: Sandy, mid brown to mid grey; inclusions: abundant, rounded lime, main fraction ≤ 0.1 mm, occasional max of 0.3mm; abundant, rounded quartz, main fraction ≤ 0.1 mm, occasional max of 0.5mm; sparse sub-angular black iron rich, occasional max of 0.5mm.

Type 24. Mid Roman Tunisian

A single whole example of this type comes from a tomb at Sāniat bin Huwaydī. The form has a short, broad, cylindrical body with a conical neck topped with a flanged rim of rounded sectional profile. The basal spike has been restored in the drawing. There are two handles which attach at the neck, springing from immediately below the rim and the shoulder. The capacity has been estimated using the same method as described for Type 19. The form has affinities with the Tunisian 'Africana I' series.

CMD No	Context	Other Information
1716	GER 001.3	
2499	GER 002 (2, 67)	
2639	GER 002 (2, 67)	
2771	GER 002 (4, 92?)	
1863	GER 001.4 (99)	
4281	GER 011 (T 6/A1.4)	Capacity: 29.6 l

Fabric: The vessel could not be identified in the Jarma Museum store and thus we do not have a full fabric description. Charles Daniels' notes describe it as 'grey fabric, white flecks, dark surface slip'.

Type 25. Mid Roman Tunisian

The shape has affinities with the Africana II series, though the other pottery which it is associated with at TIN 001 is largely earlier, that is 3rd century BC to 1st century AD. Fabric: Sandy red brown with black external surface; inclusions: moderate sub-angular quartz, main fraction ≤ 0.1 mm, a little 0.1-0.2mm; sparse rounded lime, occasional max of 1.5mm.

CMD No	Context	Other Information
6022	GER 001.3	
	LEK 006	
3698	TIN 001	

Type 26. Mid Roman Tripolitanian?

There are four complete examples of this type deriving from tombs at GER 011 (Sāniat bin Huwaydī). The form has a short, broad, cylindrical body with a conical neck topped with a flanged rim. There are two handles which attach at the neck, springing from immediately below the rim and the shoulder. The form of the basal spike varies. It is solid in [4250] and hollow in [4282] and [4237], while in [4279] it has been reduced to a knob. The capacities have been estimated using the same method as described for Type 19. The form is very similar to Type 24 and has affinities with the mid Roman 'Africana' series of Tunisian origin (Peacock and Williams 1986, Class 34). Keay (1984) summarises the evidence for the dating of the type around the western Mediterranean and suggests a range of late 2nd – 4th centuries AD. At Sabratha an almost complete example of the type occurred in a context dating to between the mid 3rd and mid 4th centuries AD (Dore and Keay 1989, 44, Type 18).

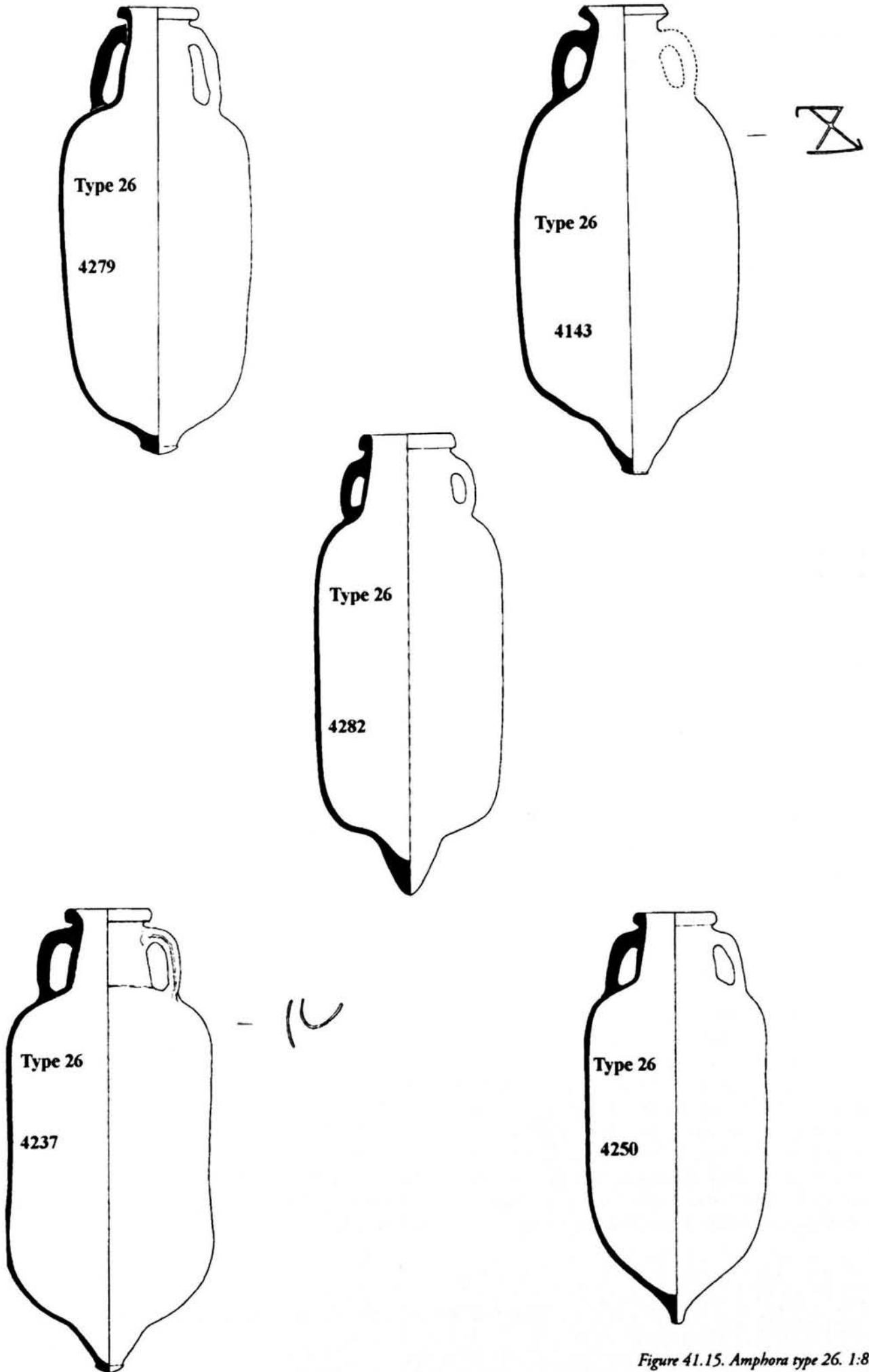

Figure 41.15. Amphora type 26. 1:8.

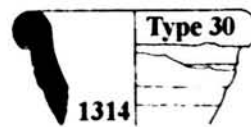
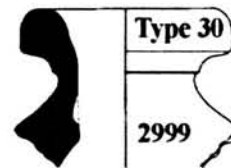
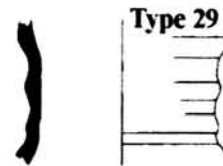
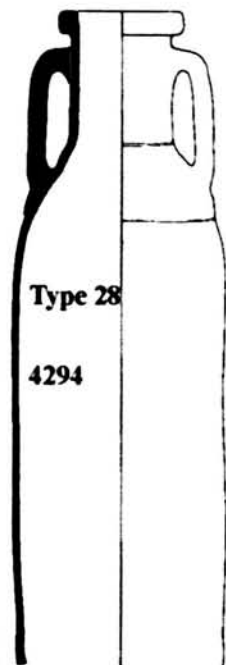
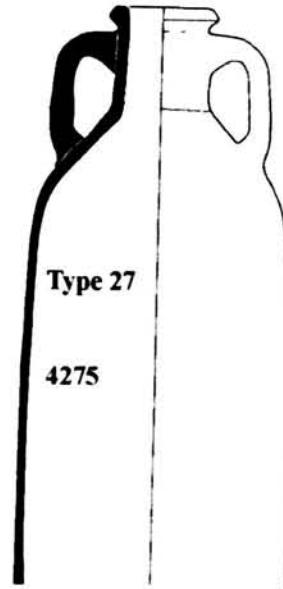
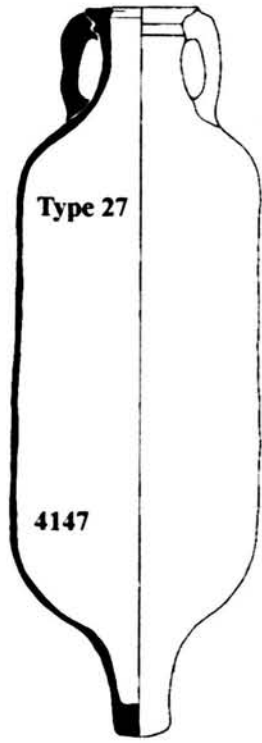

Figure 41.16. Amphora types 27-30. 1:4 (29-30), 1:8 (27-28).

CMD No	Context	Other Information
4143	GER 011 (T 17W)	
4250	GER 011 (T 42D)	Dark plum surface, red fabric. Capacity 18.9 l
4237	GER 011 (T 52C)	Brick red plum fabric. Mark cut on shoulder Capacity: 27.5 l
4282	GER 011 (T 9A)	Reddish fabric, dark plum exterior. Capacity: 23.6 l
4279	GER 011 (T 9B)	Dark brownish fabric, black-brown surface. Capacity: 22 l

Fabric: The vessels could not be identified in the Jarma Museum store and thus we do not have full fabric descriptions. The descriptions from Charles Daniels' notes are given in the table below.

Type 27. Mid Roman

A similar form to Type 26. Both examples are from the tombs at Sāniat bin Huwaydi.

CMD No	Context	Other Information
4147	GER 011 (T 15C)	Buff surface, red brick fabric, possibly also dark grey, no slip
4275	GER 011 (T 53F)	Grey fabric, white flecks, dark surface

Fabric: The vessels could not be identified in the Jarma Museum store and thus we do not have full fabric descriptions. The descriptions from Charles Daniels' notes are given in the table below.

Type 28. Mid Roman

A single example from the tombs at Sāniat bin Huwaydi. The form is similar to type 26, but taller and narrower. The estimated capacity is at least 18 l.

CMD No	Context	Other Information
4294	GER 011 (T 53B)	Red fabric with slip

Fabric: The vessel could not be identified in the Jarma Museum store and thus we do not have a full fabric description. The description from Charles Daniels' notes is given in the table above.

Type 29. Benghazi Mid Roman 7

A wall sherd from an example of Riley's Mid-Roman Amphora 7 from the Aegean (Riley 1979, 189-93, who details the occurrence and distribution of the type and is of the opinion that its date is confined to the 3rd and 4th centuries AD).

CMD No	Context	Other Information
	ZOU 002	

Fabric: Hard, sandy red-brown with darker surface; inclusions: common quartz, mostly ≤ 0.5 mm, some up to 0.5mm.

Types 30-36 Late Roman

Type 30. Spatheia

The type commonly known as Spatheia (Peacock and Williams 1986, Class 51; Riley 1979, Late Roman Amphora 8a). The type occurred in levels of the 6th century AD at Berenice/Benghazi and Riley (1979) was of the opinion that it did not appear earlier. At Sabratha examples of the type occur in contexts which could be as early as the 5th century AD (Dore and Keay 1989, Type 30) and Freed is of the opinion that this type of small Spatheion went out of production in the Vandal period (Freed 1995, 170).

CMD No	Context	Other Information
2999	CHA 001	
1314	GSC 003 (G)	

Fabric: Gritty mid-brown with a dark grey core; inclusions: abundant, poorly sorted, well rounded quartz, main fraction 0.3-0.5mm, a little 0.5-0.7mm; abundant rounded lime, main fraction ≤ 0.1 mm, a little 0.1-0.2mm.

Type 31. Late Roman 1

Late Roman Amphora type 1 probably originating in northern Syria (Riley 1979, 212-6; Riley 1981, 120; Peacock 1984, 119). 5th-7th century AD. The occurrence of this type in the Wadi al-Ajial was only firmly established comparatively recently (during the 2000 season of the Fezzan Project). A limited re-examination of material in the Jarma Museum store was made in order to search for further occurrences of this and other late types, but not all the material could be located and thus the list of contexts given below should not be regarded as exhaustive.

CMD No	Context	Other Information
	CLF 003	
	GBD 001 (NW Quad)	
3842	GRE 001A	
	LEK 009	
	GSC 030 (T 20/21F)	

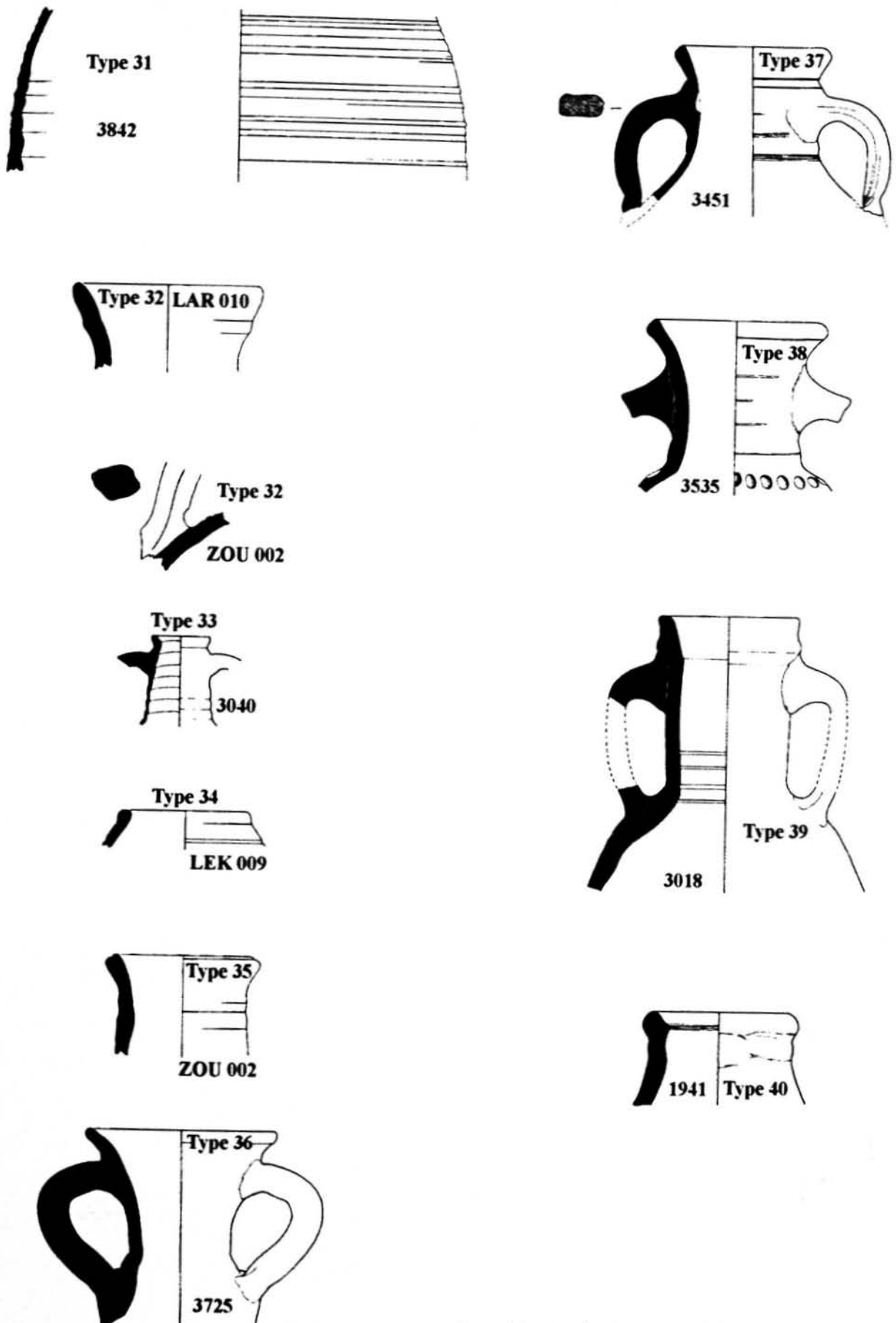

Figure 41.17. Amphora types 31-40. 1:4.

Fabric: Sandy, grey-, pinkish-, or yellowish-brown with (in one example) a thick grey-brown core; one example shows a wet-slipped yellowish-cream outer surface; inclusions: moderate to abundant rounded quartz, mostly 0.2-0.5mm, moderate sub-angular black vitreous grains, 0.2-0.5mm; two examples show moderate rounded lime, 0.2-0.6mm.

Type 32. Late Roman 2

Late Roman Amphora Type 2, produced in Turkey (and probably other places; Riley 1979, 217-9; Riley 1981, 122; Peacock 1984, 119). Late 4th – late 6th centuries. The remarks on the recorded distribution of these late types in the Wādī al-Ajāl made above under type 31 also apply.

CMD No	Context	Other Information
	LAR 010	
	ZOU 002	

Fabric: 1. Sandy orange pink with a greenish-orange outer surface and orange-brown inner; inclusions: moderate limestone up to 1.0mm in a silty matrix; limestone is mostly void on the surface. (LAR 010).

2. Sandy warm mid-brown with pale yellowish-cream surface; inclusions: abundant rounded quartz up to 0.5mm; moderate rounded red and black iron-rich grains, 0.2-0.5mm. (ZOU 002).

Type 33. Late Roman 3

Carthage Late Roman Amphora Type 3, probably from Asia Minor (Riley 1981, 118; Peacock 1984, 121). 5th and 6th centuries AD. The remarks on the recorded distribution of these late types in the Wādī al-Ajāl made above under type 31 also apply.

CMD No	Context	Other Information
3040	CHA 001	Hard buff sandy fabric; light slip
	GSC 001 (C)	

Fabric: The vessels could not be identified in the Jarma Museum store and thus we do not have full fabric descriptions. The descriptions from CMD's notes are given in the table below.

Type 34. Late Roman 4

Carthage Late Roman Amphora 4 originating from Gaza in Palestine (Riley 1979, 219; Riley 1981, 120; Peacock 1984, 121, no. 5). It seems to be present at Carthage before the end of the 4th century AD (Riley 1984, 120) and continued to be imported certainly to the end of the 6th century.

CMD No	Context	Other Information
	LEK 009	

Fabric: Sandy red-brown; inclusions: abundant rounded quartz mostly ≤ 0.2 , some up to 0.5mm.

Type 35. Keay Type 52

A possible example of Keay Type 52. The identification was suggested by comparison with an example on display in the Byrsa Museum at Carthage. 4th-6th (at least) century AD (see Peña 1999, 73; Pacetti 1998). At Sabratha an example occurs in a fill predating the reversion of Regio II, Insula 10 to domestic purposes at the end of the 4th century AD (Dore and Keay 1989, 46, Type 22).

CMD No	Context	Other Information
	ZOU 002	

Fabric: Sandy red-brown with cream coloured surface.

Type 36. Late Roman

A single example of a type which has parallels in late 5th – early 6th century AD deposits at Carthage (Peacock 1984, fig. 39, nos 53-55)

CMD No	Context	Other Information
3725	RUG 001 (G)	

Fabric: Well-fired, sandy, dark grey; inclusions: abundant rounded quartz mostly ≤ 0.2 mm, occasionally up to 0.5mm.

Types 37-43 Probable Late Roman

Type 37. Probable Late Roman

Unassigned, probably late. Possibly another example of Late Roman Amphora 2 (see type 32).

CMD No	Context	Other Information
3451	CLF 002	

Fabric: Red fabric, fired dark to purple in places on external surface.

Type 38. Probable Late Roman

Unassigned, probably late.

CMD No	Context	Other Information
3535	ZOU 002 (G)	

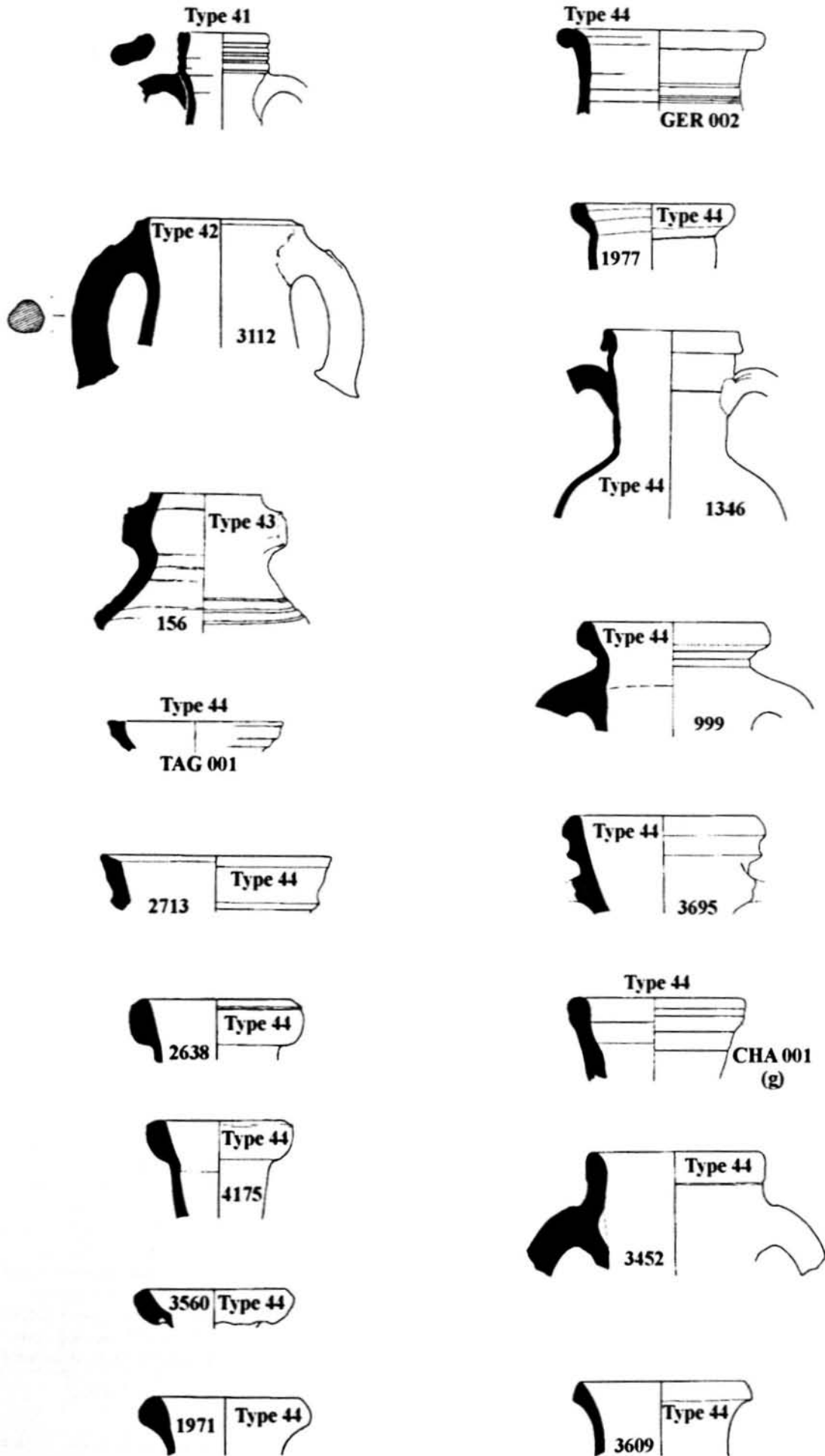

Figure 41.18. Amphora types 41-44. 1:4.

Fabric: Sandy, red-brown with black surface; inclusions: abundant rounded quartz, mostly ≤ 0.1 mm, some 0.2-0.3 mm, occasionally up to 0.5 mm; sparse rounded lime, 0.2-0.5 mm.

Type 39. Probable Late Roman

Unassigned, probably late.

CMD No	Context	Other Information
3018	FJJ 006 (1)	

Fabric: Red, coarse red slip.

Type 40. Probable Late Roman

Unassigned, probably late.

CMD No	Context	Other Information
1941	GER 003 (115)	

Fabric: Sandy orange-brown; abundant rounded quartz and lime ≤ 0.1 mm.

Type 41. Probable Late Roman

Unassigned, probably late.

CMD No	Context	Other Information
	BBA 015	

Fabric: Orange, white external surface.

Type 42. Probable Late Roman

Unassigned, probably late.

CMD No	Context	Other Information
1312	GSC 005 (g)	

Fabric: Sandy mid-brown to grey; inclusions: abundant rounded quartz mostly ≤ 0.1 mm, occasionally up to 0.5 mm; abundant rounded lime, mostly ≤ 0.1 mm, occasionally up to 0.3 mm; sparse sub-angular black iron-rich grains, 0.2-0.5 mm.

Type 43. Probable Late Roman

Unassigned, probably late.

CMD No	Context	Other Information
156	TAG 001 (G01)	

Fabric: Reddish-buff, hard yellow slip on external surface.

Type 44. Miscellaneous Unassigned

Miscellaneous unassigned amphorae.

CMD No	Context	Other Information
3609	Jarma area	Sandy red-brown, black outer surface; inclusions: moderate sub-angular quartz, main fraction ≤ 0.1 mm; a little 0.1-0.2 mm sparse rounded lime, occasional max of 1.5 mm
6000	Jarma area	Well-fired, sandy dark grey; inclusions: abundant rounded quartz, main fraction ≤ 0.1 mm, some 0.1-0.2 mm, occasional max of 0.5 mm
1919	Jarma area	Yellowish-grey slip
1977	CHA 001	
2999	CHA 001	Sandy, dark, lime-rich fabric
1929	CHA 001	Black
1971	CHA 001 (g)	Darkish fabric, grey surface
1972	CHA 001 (g)	White plum inside and grey plum outside, traces of light slip
1992	CHA 001 (g);	Hard sandy brown fabric; lime and red grains visible
3452	CLF 002	Black surface; traces of slip
3845	FJJ 006	
3082	FJJ 006 (2)	Sandy, dark pink lime-rich fabric,
	TAG 001	
	CHA 001 (grab)	
1334	GER 002	
3049	FUG 003	
3560	GEL 004 (G)	Dark lime-rich fabric, black surface
	GER 002	
1569	GER 001.1	Hard grey fabric
6003	GER 001.3	Sandy pale grey, dull orange brown surfaces; inclusions: abundant rounded quartz, main fraction ≤ 0.1 mm, a little 0.2-0.5 mm
2337	GER 001.3	
6023	GER 001.3	Dark grey, thin well defined, greenish cream slip over outer surface; inclusions: sparse rounded quartz, main fraction 0.1-0.2 mm; sparse rounded lime, main fraction 0.1-0.2 mm; silty matrix

Figure 41.19. Amphora types 44 (cont). 1-4.

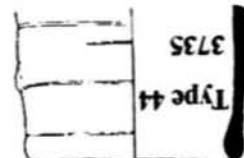
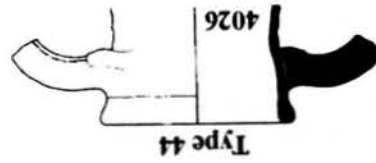
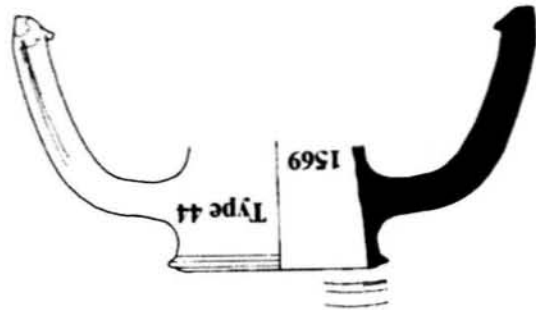
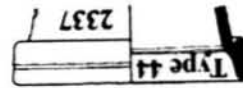
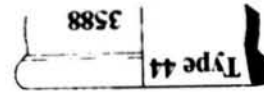
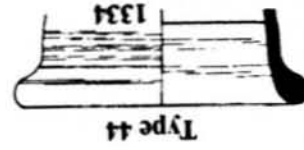
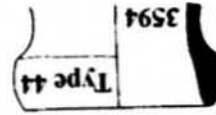
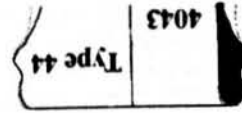
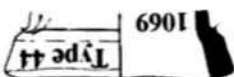
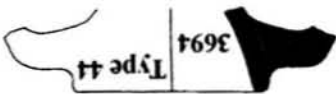
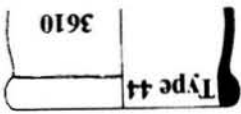
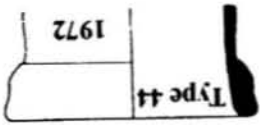
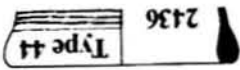
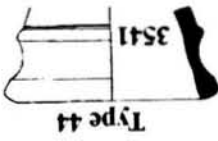
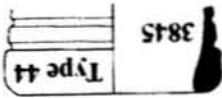
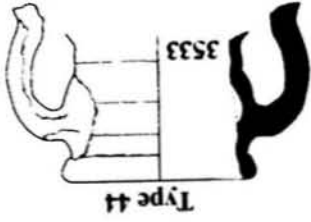
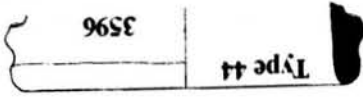

CMD No	Context	Other Information
6051	GER 001.3	Sandy red-brown, black outer surface; inclusions: moderate sub-angular quartz, main fraction ≤ 0.1 mm, a little 0.1-0.2mm; sparse rounded lime, occasional max of 1.5mm
6015	GER 001.3	Sandy dark grey; inclusions: abundant rounded quartz, main fraction ≤ 0.1 mm, some 0.1-0.2mm, occasional max of 0.5mm
2276	GER 001.3 (2, 13)	Sandy red-brown, black surfaces; inclusions: abundant rounded quartz, main fraction 0.1-0.3mm, a little 0.4-0.6mm, occasional max of 1.5mm
2713	GER 001.3 (7 55)	
6017	GER 016 (909)	Sandy pale grey, dull orange brown surfaces; inclusions: abundant rounded quartz, main fraction ≤ 0.1 mm, a little 0.2-0.5mm
2705	GER 002	
2780	GER 002	
2636	GER 002	
2526	GER 002	
3102	GER 002	
3374	GER 002	
2336	GER 002 (2, 12)	Fine orange-brown, diffuse brownish grey core core; inclusions: moderate rounded quartz, main fraction 0.1-0.2mm; moderate rounded lime, main fraction 0.1-0.2mm, occasional max of 2mm; moderate angular red grains, main fraction ≤ 4 mm; moderate angular black grains, main fraction ≤ 4 mm
2436	GER 002 (2, 30)	Red buff with dark brown surface
2638	GER 002 (4, 30)	Dark grey
2079	GER 003 (113)	Dark liver-coloured, plumb-coloured external surface with yellowish patches
1069	GSC 003	Hard grey fabric
1346	GSC 006 (g)	BW
1013	GSC 001	
4026	LEK 007 (S)	Hard black
3819	LEK 009	Sandy dull red fabric, darker surfaces and a lighter slip
3235	RUG 003	Gritty dark red fabric, black surface

CMD No	Context	Other Information
4043	TIN 001 (B)	Hard dark grey fabric; some lime flecking
3694	TIN 001 (B)	Buff fabric
3679	TIN 001 (B, 12, S)	Gritty grey-brown, grey surface with cream slip on outside; inclusions: abundant well rounded quartz, main fraction ≤ 0.2 mm, some 0.3-0.5mm, occasional max of 3.5mm
3695	TIN 001 (B, 17, S)	Sandy red-brown, black surfaces; inclusions: abundant, rounded quartz, main fraction 0.1-0.3mm, a little 0.4-0.6mm, occasional max of 1.5mm
3594	TIN 001 (BE, A)	Dark grey
3596	TIN 001 (BE, A)	Sandy red-brown, black surfaces; inclusions: abundant rounded quartz, main fraction 0.1-0.3mm, a little 0.4-0.6mm, occasional max of 1.5mm
6034	TIN 001 (BE, B)	
3588	TIN 001 (BE)	Sandy red-brown, black surfaces; inclusions: abundant rounded quartz, main fraction ≤ 0.1 mm, occasional max of 0.6mm
3610	TIN 001 (BE, B)	GW1
4175	TWE 002	
4174	TWE 002 (B)	
1602	ZIN 001-003	
566	ZIN 001-003	
614	ZIN 109 (12)	Hard brown fabric; brown slip
3541	ZOU 002	Sandy red-brown, red inner surface, even matt black (Slip?) on outer surface; surfaces wiped and smoothed; inclusions: abundant rounded quartz, main fraction ≤ 0.1 mm, some 0.1-0.2mm, a little 0.2-0.5mm; sparse rounded lime, main fraction \leq mm, occasional max of 0.3mm
3533	ZOU 002	Dark, lime rich liver coloured fabric
3541	ZOU 002	Sandy red-brown, red inner surface, even matt black (Slip?) on outer surface; surfaces wiped and smoothed; inclusions: abundant rounded quartz, main fraction ≤ 0.1 mm, some 0.1-0.2mm, a little 0.2-0.5mm; sparse rounded lime, main fraction \leq mm, occasional max of 0.3mm

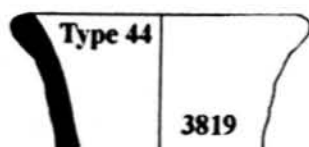
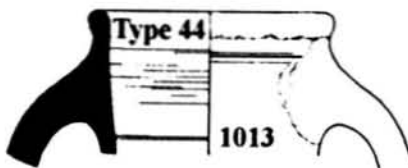
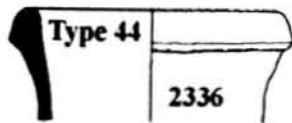
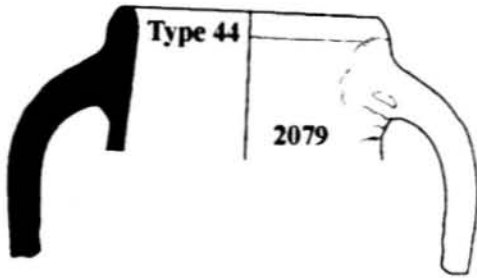
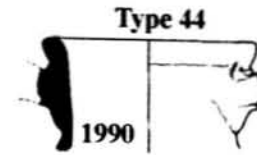
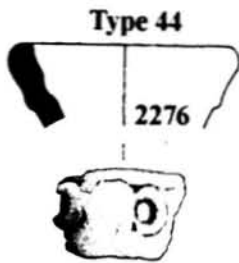
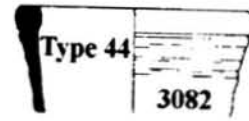
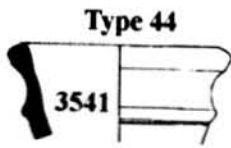
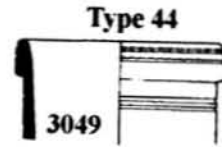
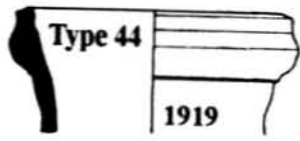

Figure 41.20. Amphora types 44 (cont). 1-4.

PART D. COARSEWARE

Types 101-106. Large Bowls

The superordinate type of which these can all be regarded as sub-types is a large, heavy bowl, not overly deep, with a body of gently curving sectional profile; the rim forms a broad, projecting, down-turned flange; the foot, in the few examples where it survives (see Type 103, 3020 and Type 104, 3021), is plain or carries a simple moulding. In types 101 and 102, the upper face of the rim flange carries a shallow, concave lid-locating facet on its back face which gives the rim the appearance of being articulated as two distinct elements. A distinction is made between type 101 which has this facet located below and behind the highest point of the rim, and type 102 where the location of the facet coincides with the highest point of the rim. Types 103 and 104 do not exhibit this lid-locating facet; a distinction is made between them on the basis of the concave shape of the upper surface of the rim in 103. Types 105 and 106 are represented by only a single vessel apiece; type 105 has a slight 'beak' at the heel of the rim; type 106 is very shallow with a plain rim.

The majority (75%) of the examples of these types occur at Tinda (TIN 001).

Parallels for types 101 and 102 occur at Sabratha (type 238 – probably residual in a context of the late 1st century BC), and in the levels associated with the residential insulae on the south slope of the Byrsa Hill at Carthage, which date from about the mid 3rd century BC to the destruction of 146 BC (see *Byrsa I and II*).

Type 101

CMD No	Context	Other Information
766	GER 001.3	
770	GER 001.3	
3702	TIN 001 (B, 17, s)	
3708	TIN 001 (B, 23, s)	
3682	TIN 001 (B, 12, a)	
3663	TIN 001 (A)	
3617	TIN 001 (BE)	Dark sandy fabric
3708	TIN 001 (BE)	Dark fabric, white fill. Black on both surfaces
3582	TIN 001 (BE)	Flakey fabric, interior surface black, exterior surface red-brown

Type 102

CMD No	Context	Other Information
3834	TIN 001 (A)	Sandy fabric, some white flakes. Dark grey surfaces
3645	TIN 001 (A)	Red fabric, dark surface
3636	TIN 001 (A)	Dark core and dark surface
3690	TIN 001 (B, 15, G)	
3621	TIN 001 (BE)	Dark fabric, fill dark red

Type 103

CMD No	Context	Other Information
3021	FJJ 004	Blackish, partially misfired
3678	TIN 001 (B, 12, s)	
3675	TIN 001	Dark fabric, hard
3677	TIN 001 (B, 1, SF)	

Type 104

CMD No	Context	Other Information
3020	FJJ 002	
3238	GRE 001	
	GER 002 (60, s)	
1420	GER 002 (D, g)	Grey

Type 105

CMD No	Context	Other Information
1570	GSC 016	

Type 106

CMD No	Context	Other Information
1675	GSC 016	

Fabric: Many of the examples of these types are in a distinctive fabric which is close to that of Amphora Type 9. Sandy, occasionally gritty red-brown, smoothed black surfaces; inclusions: moderate, rounded quartz, main fraction <=0.1 mm, some 0.1-0.2mm, a little 0.2-0.5mm; sparse, rounded lime, up to 0.5m.

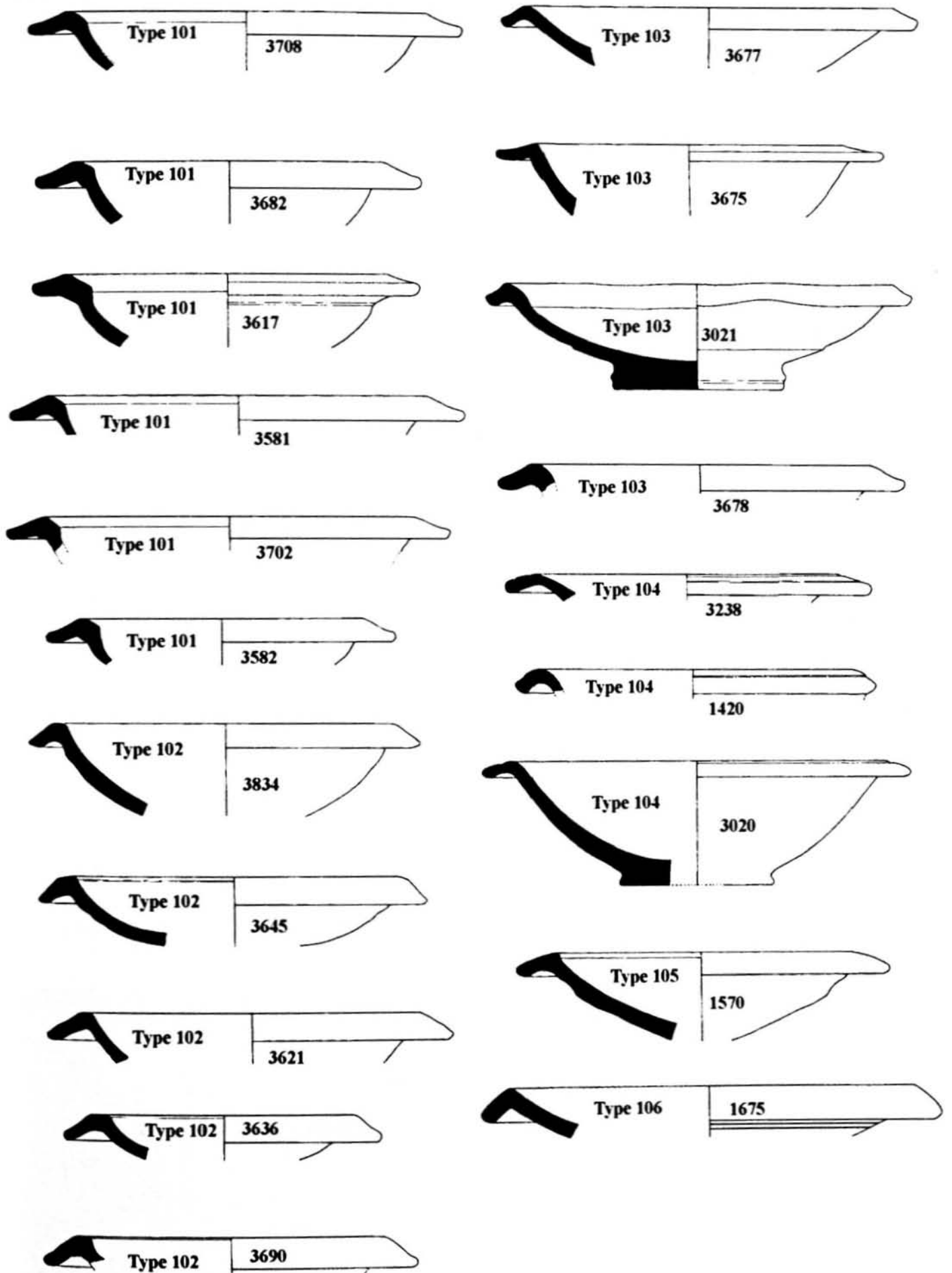

Figure 41.21. Coarseware types 101-106. 1:4.

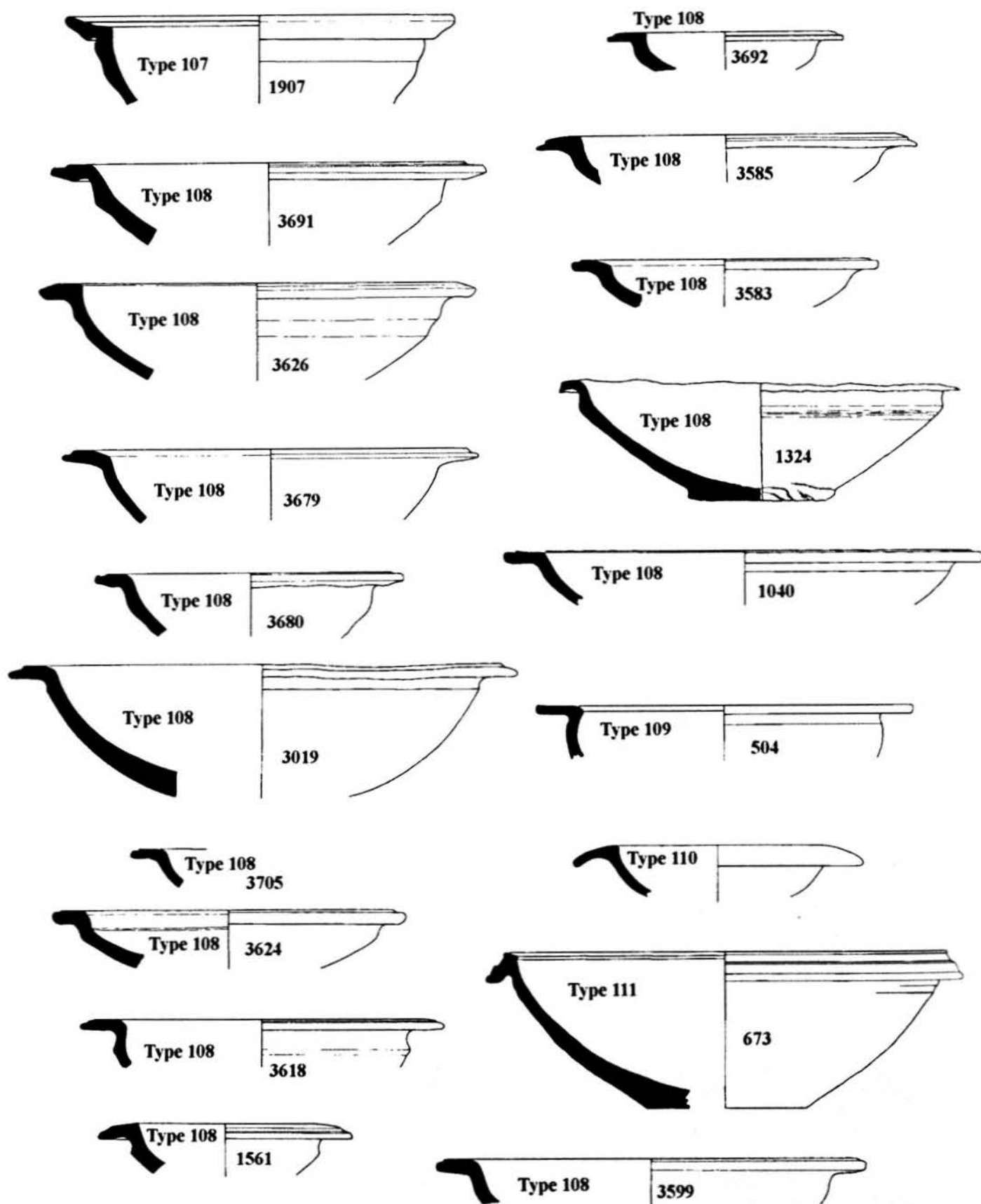

Figure 41.22. Coarseware types 107-111. 1:4.

Type 107. Large Bowl

The best general parallel for this vessel is a type of large basin which is common in the eastern Mediterranean and along the North African coast as far as Carthage in deposits of the latest 1st century BC and 1st century AD. See, for example, Benghazi ER Plain Ware 1 (Riley 1979), Sabratha Types 213-4, Carthage: Early Roman Buff Ware Basin Type 1 (Hayes 1976).

CMD No	Context	Other Information
1907	FUG 001	Dark grey fabric

Type 108. Large Bowl

A medium to large bowl. In the majority of examples, the upper and lower wall of the body are articulated as two distinct elements, the upper approximately vertical and the lower mostly taking the form of an inverted cone. In a few examples (3826 and 3019) the articulation is barely present. The rim forms a broad flange, usually approximately horizontal, whose lip carries a single rebate. The best parallels, in terms of the overall size and form of the vessels, are among the early Roman basins at Sabratha, particularly type 215 (Dore and Keay 1989).

CMD No	Context	Other Information
3680	TIN 001 (B, 12, s)	
3019	FJJ 003	Reddish surface
1324	GSC 008	Brick red fabric, hard metallic, more brownish internal and external
1561	GSC 013	
3691	TIN 001 (B, 15, s)	
3692	TIN 001 (B, 15, s)	
3599	TIN 001 (B)	Dark fabric surface
3792	TIN 001 (B)	Red quartz
3705	TIN 001 (B)	Dark fabric, red inside, grey outside
3679	TIN 001 (B, 12, s)	
3618	TIN 001 (BE)	Dark fabric, red inside, greyish brown outside
3626	TIN 001 (BE)	Dark grey fabric, lighter slip traces
3585	TIN 001 (BE)	Reddish fabric, brownish surface

CMD No	Context	Other Information
3583	TIN 001 (BE)	Dark fabric, light slip
3624	TIN 001 (BE)	Dark grey fabric, blackish surface, hard
1040 [DZ 222]	ZIN 119	Metallic hard grey with brownish surface

Fabric: Gritty grey-brown, grey surface with cream slip on outside; inclusions: abundant well-rounded quartz, main fraction ≤ 0.2 mm, some 0.3-0.5mm, occasional max of 3.5mm

Type 109. Large Bowl

Related to type 108?

CMD No	Context	Other Information
504	ZIN 109	Hard black self-coloured fabric

Type 110. Small Bowl

A finely-made small bowl with down-turned flange rim. The type is one of a series of similar small bowls identified at Sabratha as dating to 1st century BC – 1st century AD (Dore and Keay 1989, Types 207-212). It is closest to Sabratha Type 209 (for other examples see Dore 1992, no. 76, from Leptiminus; Arthur 1983, fig. 8, no. 72 and fig. 9, no. 88, from an assemblage of broadly similar date recovered from a site near Mişurāta).

CMD No	Context	Other Information
	GER 002 (5)	

Fabric: Sandy cream, pinkish-brown core, greenish-cream outer surface; the rim-top is slipped and burnished; the remainder of the outer surface and under the flange is wiped but not slipped; the inner surface is abraded; inclusions: abundant, rounded quartz, main fraction ≤ 0.1 mm, a little 0.1-0.2mm; abundant rounded lime, main fraction ≤ 0.1 mm, a little 0.1-0.2mm.

Type 111. Large Bowl

A single example; bowl with downturned flange rim. Date possibly as types 107 and 108.

CMD No	Context	Other Information
673	TIN 001	Reddish fabric, sandy with white inclusions; dark surface

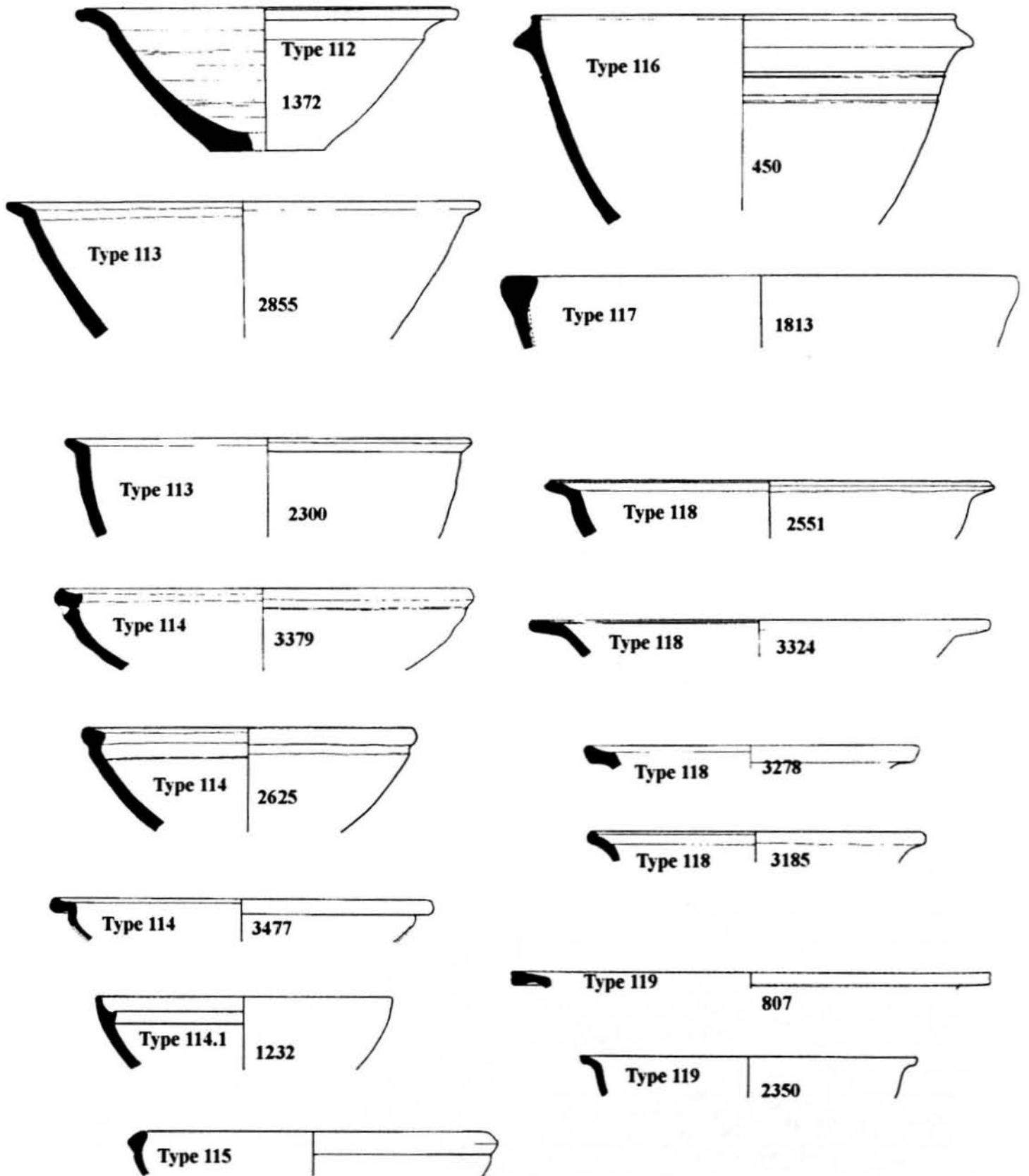

Figure 41.23. Coarseware types 112-119. 1:4.

Types 112 – 113. Large Bowls

Basin with up-tilted flange rim: in type 112 the rim is long and curved, in type 113 it is shorter and straight. The context of the two examples of Type 113 (Sāniat Jibril) can be dated on structural grounds to the late 2nd–3rd century AD.

Type 112

CMD No	Context	Other Information
1372	GSC 008 (1)	Hard, dull brown fabric with some white inclusions; dark purple surface
1546 [DZ 402]	ZIN 109	Hard metallic dark red with brownish surface

Type 113

CMD No	Context	Other Information
2300	GER 002 (6, 2)	
2855	GER 002 (6, 9)	Sandy dark grey, darker surfaces, burnished inner surface
2726	GRE 001 (C)	

Type 114 Medium Bowl

This type of medium-sized bowl with horizontal or up-tilted flange rim is known to have been produced at Leptiminus (see Dore 1992, nos. 52–4). Late 2nd–4th centuries AD. One example (2625) comes from a context which can be assigned on structural grounds to the late 2nd–3rd century AD.

CMD No	Context	Other Information
3379	GER 002 (2, g)	
2625	GER 002 (7, 2)	
3477	ZOU 001 (G)	
2799	ZOU 002	

Fabric: Sandy orange-brown, reddish-brown core, dark grey outer surface; surfaces smoothed and burnished; inclusions: abundant rounded quartz, main fraction 0.1–0.2mm, some 0.2–0.5mm–1.5mm; sparse rounded lime, main fraction 0.1–0.3mm.

Type 115. Medium Bowl

A medium-sized bowl with inturned lip and moulded face. This type occurs in the Tripolitanian pre-desert (Dore 1996, no. 110) in contexts which suggest a date of c.2nd–5th century AD. It may well be formally related to a series of bowls of mid-Roman date produced at Leptiminus (see Dore 1992, nos. 50–52). The fabric also is known

in the pre-desert area (see particularly the examples of Casserole Type 77 from Wādi Umm al-Kharab – Dore 1996, no. 377).

CMD No	Context	Other Information
	GER 002 (3, 5))	

Fabric: Sandy dark grey brown with thin orange sub-surface margins and a banded grey and brown wet-hand-slipped surface brown surface; inclusions: moderate rounded quartz, main fraction <=0.1mm, some 0.5–1mm.

Type 116. Large Bowl

Miscellaneous large bowl.

CMD No	Context	Other Information
450	FJJ 004	Hard metallic fabric

Type 117. Large Bowl

Miscellaneous large bowl.

CMD No	Context	Other Information
1813	GER 001.4 (150)	Bl4. Phase 2

Types 118 – 124. Medium Bowls

The formal characteristics which unite these forms are their roughly hemi-spherical body shape and their up-tilted flange rims. Types 118, 119 and 122 are quite finely made with a moulded upper face to the flange. Type 120 is shallower than the others – a dish rather than a bowl.

Type 118. Medium Bowl

These vessels are quite finely made with a moulded upper face to the flange. All the examples come from Sāniat Jibril (GER 002). No. 2551 is from a context of the later 2nd to 3rd century AD. Parallels are known from Sabratha (Dore and Keay 1989, 189, no. 198.3096 – from a poorly stratified context, and 193, no. 214.3911 from a homogenous group with a *TPQ* of c.10 BC from the Antonine Temple; also see Arthur 1983, fig. 6, no. 65, from Marsa Jazira near Mişūrāta; Sabratha type 207, Dore and Keay 1989).

CMD No	Context	Other Information
2551	GER 002 (2, 56)	
3324	GER 002 (121, s)	
3278	GER 002 (107, s)	
3185	GER 002 (46, s)	

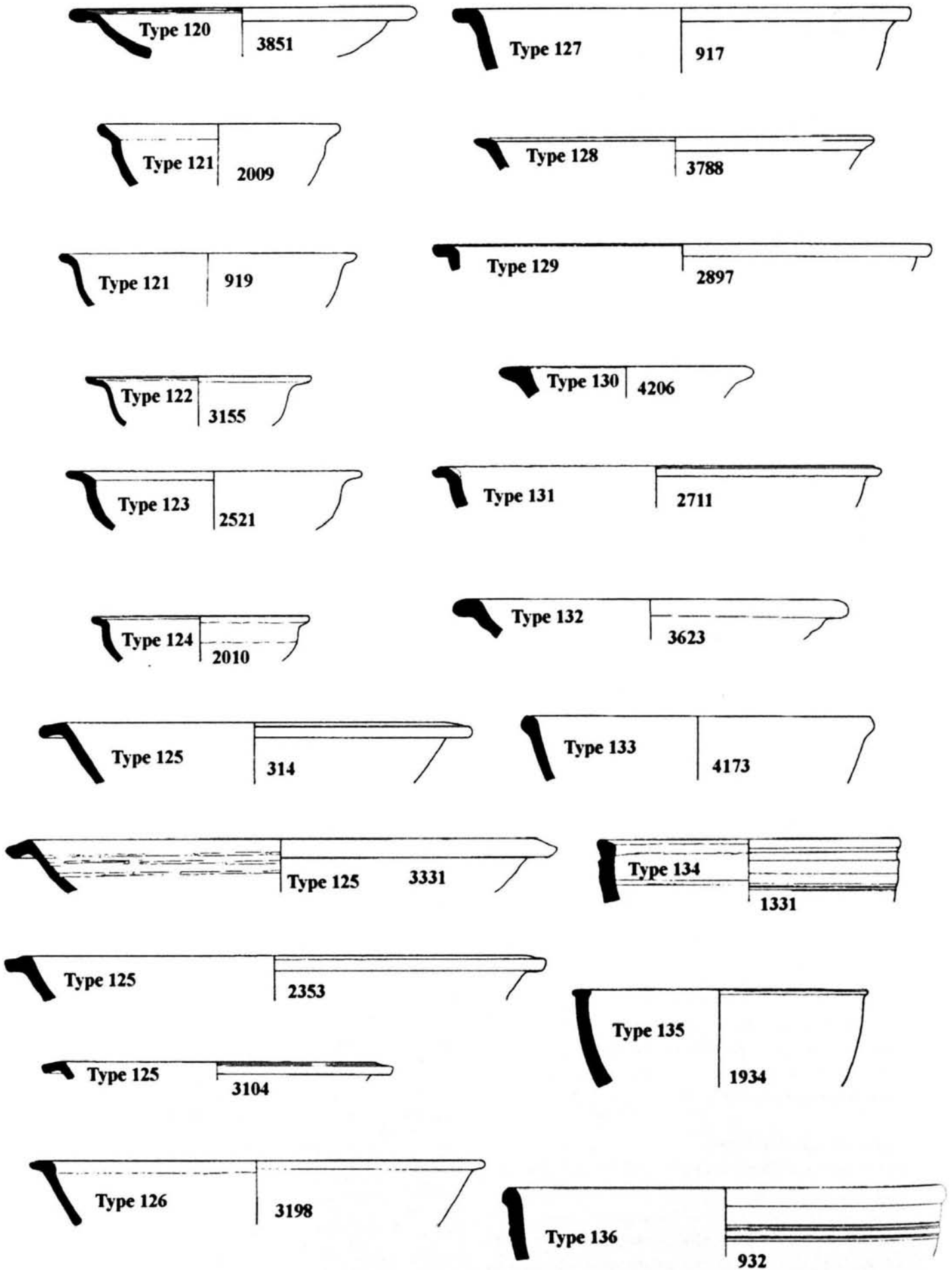

Figure 41.24. Coarseware types 120-136. 1:4.

Fabric: Fine red-brown, thin dark grey core, dark grey to black surfaces; surfaces smoothed; inclusions: moderate rounded quartz, main fraction ≤ 0.1 mm, occasional max of 0.2mm; sparse rounded lime, main fraction ≤ 0.1 mm, occasional max of 0.2mm.

Type 119. Medium Bowl

Similar to Type 118. The upper face of the rim flange is un moulded. No. 807 is from a deposit likely to date to the late 2nd-3rd centuries AD. No. 2350 comes from a late 1st-early 2nd century deposit at Sāniat Jibril

CMD No	Context	Other Information
2350	GER 002 (6, 10)	Sandy grey-brown with smooth surface
807	GER 001.4 (19)	Grey burnished fabric

Type 120. Medium Bowl

A single example of a dish with a broad, up tilted flange rim, thickened at the lip.

CMD No	Context	Other Information
3851	GRE 001 (A)	Sandy fabric, light brown, dark surface

Type 121. Medium Bowl

Miscellaneous bowls with up turned flanges.

CMD No	Context	Other Information
2009	CHA 001	Hard dark grey fabric, almost black
919	GER 002 (g)	

Fabric: Sandy dark grey, dark purple outer surface; inner and outer surfaces burnished; inclusions: abundant rounded quartz, main fraction ≤ 0.1 mm, some 0.1-0.2mm; sparse rounded lime, main fraction ≤ 0.1 mm, occasional max of 0.3mm.

Type 122. Medium Bowl

Miscellaneous bowl with up turned flange; the upper face of the flange is grooved.

CMD No	Context	Other Information
3155	GER 002 (30, s)	Grey fabric with white flecks.

Type 123. Medium Bowl

Miscellaneous bowl with up turned flange. This piece comes from a context likely to date to the later 2nd century AD.

CMD No	Context	Other Information
2521	GER 002 (2, 55)	

Fabric: Sandy dark grey-brown, greenish-cream slip or wash over the upper wall and rim; inclusions: abundant rounded quartz, main fraction ≤ 0.1 mm, some 0.1-0.2mm, a little 0.2-0.3mm, occasional max of 0.5mm; sparse rounded lime, 0.1-0.2mm; sparse rounded red iron-rich grains up to 0.5mm

Type 124. Medium Bowl

Miscellaneous bowl with up turned flange.

CMD No	Context	Other Information
2010	GER 002 (g)	Grey fabric with brown core and purplish grey-brown surface

Type 125. Medium Bowl

Bowl or dish with downturned flange rim. These appear to have been unslipped though they may be related to TRS (Hayes Form 2) or ARS (Hayes Form 58). All the examples are from Sāniat Jibril and 314 is from a context likely to date to the later 3rd or 4th centuries AD.

CMD No	Context	Other Information
3104	GER 002 (3, s)	
314	GER 002 (4, 2/1)	
3331	GER 002 (130, s)	

Fabric: Sandy dark grey or dark red.

Types 126 – 136. Large or Medium Bowls

Large- and medium-sized bowls with flange rims of varying lengths. This is a miscellaneous category, each type being represented by one example only.

Type 126. Large or Medium Bowl

CMD No	Context	Other Information
3198	GER 002 (52, s)	Brown fabric, black slip surface

Type 127. Large or Medium Bowl

CMD No	Context	Other Information
917	GER 002 (g)	

Fabric: Sandy dark grey with darker surfaces, once burnished.

Type 128. Large or Medium Bowl

CMD No	Context	Other Information
3788	RUG 003	'Quartz bowl'

Type 129. Large or Medium Bowl

This vessel comes from a context at Sāniat Jibril dating to the late 2nd-3rd centuries AD.

CMD No	Context	Other Information
2897	GER 002 (4, 48)	

Fabric: Sandy dark grey, orange-brown core, dark brownish-grey inner surface, dark grey outer surface showing the remains of a cream slip; inclusions: moderate, rounded quartz, main fraction 0.1-0.2mm, some 0.2-0.5mm, occasional max of 1mm.

Type 130. Large or Medium Bowl

CMD No	Context	Other Information
4206	FUG 009	Dark fabric, blackfiring outside

Type 131. Large or Medium Bowl

CMD No	Context	Other Information
2711	TIN 001	Brick red fabric, cream skin on outer surface

Type 132. Large or Medium Bowl

CMD No	Context	Other Information
3623	TIN 001 (BE)	Sandy dark fabric

Type 133. Large or Medium Bowl

CMD No	Context	Other Information
4173	TWE 002 (b)	Dark grey fabric

Type 134. Large or Medium Bowl

CMD No	Context	Other Information
1331	GSC 002	Metallic grey fabric with yellowish-cream slip on outer surface

Type 135. Large or Medium Bowl

CMD No	Context	Other Information
1934	GER 003 (106)	Sandy grey burnished fabric

Type 136. Large or Medium Bowl

It seems possible that the form of this type has been influenced by that of samian form Dr. 37. The vessel is from a context dating to phase 1 of Sāniat Jibril.

CMD No	Context	Other Information
932	GER 002 (1, 3)	Phase 1

Fabric: Sandy dark grey, with darker surfaces, once burnished.

Types 137 – 142: Medium and Small Bowls with Flange Rims.**Type 137. Medium or Small Bowl**

The body of this type is generally of smoothly rounded sectional profile. The flange is plain and more or less horizontal. Vessel [3172] was examined in 2000 and although overfired appears to have born a slip. Apart from one vessel (3531 from ZOU 002) all examples of the type are from Sāniat Jibril. Vessel [169] comes from a late 1st-2nd century deposit. The type occurs at Sabratha (Type 165), though not in great quantity, with one example occurring in a deposit dating to the first half of the 1st century AD.

CMD No	Context	Other Information
3156	GER 002 (30, s);	
169	GER 002 (3, 3/1)	
3350	GER 002 (8, 1)	
3172	GER 002 (42)	
3197	GER 002 (52, s)	
3271	GER 002 (63, s)	
2995	GER 002 (g)	
3531	ZOU 002	

Fabric: Apart from [3172], the fabric is as follows: sandy orange-brown or occasionally grey, with dark grey surfaces; the outer surface is covered with a cream-coloured slip or wash; inclusions: moderate rounded quartz, main fraction <=0.1mm, some 0.1-0.2mm, occasionally up to 0.5mm; sparse rounded lime, occasional max of 0.5mm

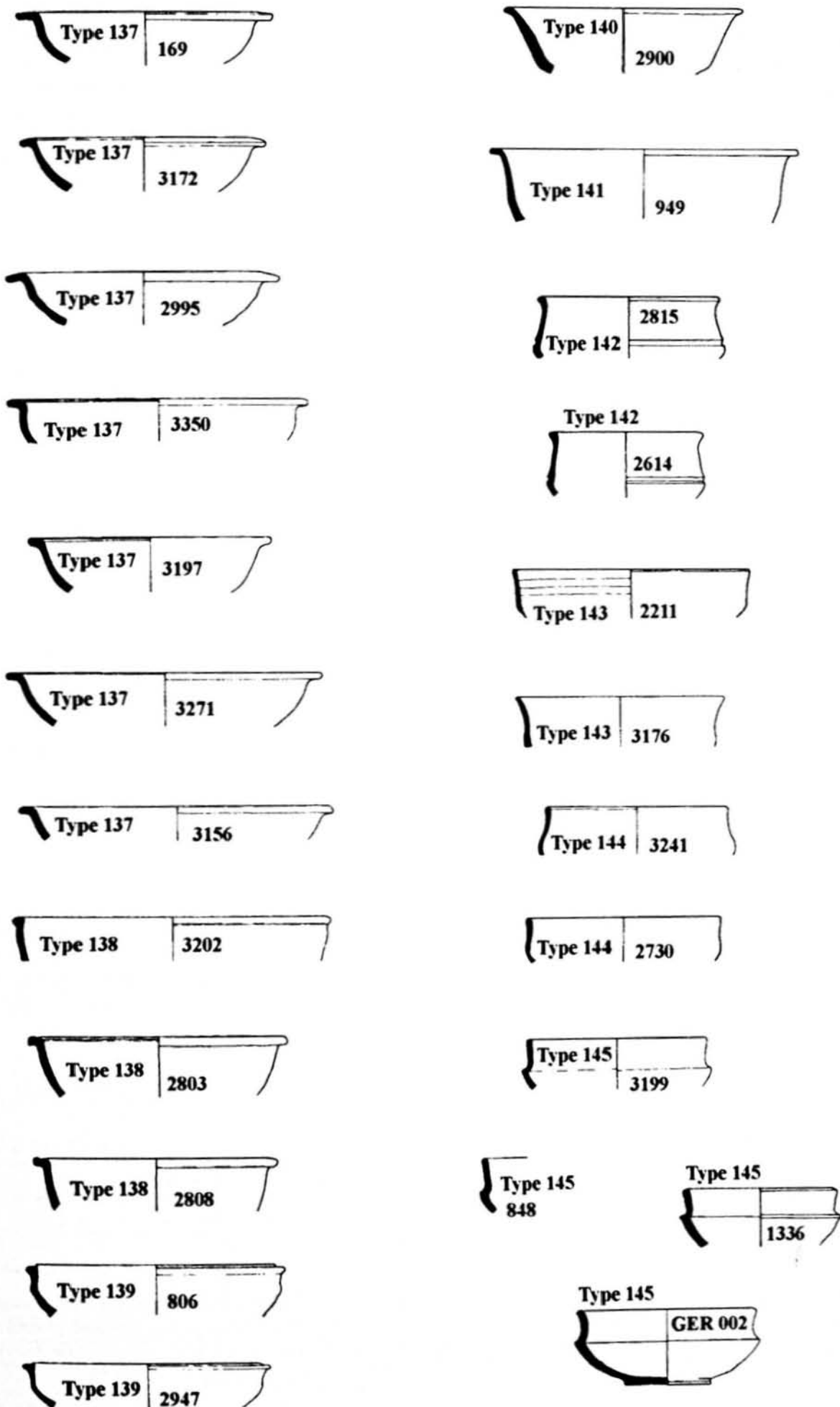

Figure 41.25. Coarseware types 137-145. 1:4.

Type 138. Medium or Small Bowl

This type has a similar general shape to 137 though the flange is generally much shorter. All examples are from Sāniat Jibril. Vessel 2803 is from a context dating to the late 1st – early 2nd century AD.

CMD No	Context	Other Information
3202	GER 002 (53, s)	
2803	GER 002 (6, 21)	
2808	GER 002 (2, 73)	

Fabric: As type 137.

Type 139. Medium or Small Bowl

Small bowls with a carinated body and a bead and flange rim. Both examples come from late 2nd-3rd century contexts. A similar form is known in the pre-desert area (Dore 1996, Type 108) where it occurs in contexts which are likely to be between the 1st and the 4th centuries AD. The fabric is also known in the pre-desert area (see particularly the examples of Casserole Type 77 from Wādi Umm al-Kharab – Dore 1996, 377).

CMD No	Context	Other Information
806	GER 001.4 (19)	
2947	GER 002 (4, 65)	

Fabric: Sandy dark grey-brown with thin orange margins and banded grey and brown surfaces; smoothed surfaces; inclusions: moderate rounded quartz, main fraction ≤ 0.1 mm, some 0.5-1 mm.

Type 140. Medium or Small Bowl

Carinated bowl with short flange rim. The form bears a striking resemblance to a late Italian sigillata form (*Conspectus Formarum* 3.2) which occurs in quantity in the tombs of Sāniat bin Huwaydī (see Fineware Type 515) and is popular in the pre-desert area (see Dore 1996: 323), but it is in a coarseware fabric. The piece comes from a late 1st century – early 2nd century context at Sāniat Jibril.

CMD No	Context	Other Information
2900	GER 002 (2, 76)	

Fabric: Sandy dark grey with banded orange and grey surfaces; smoothed surfaces; inclusions: moderate rounded quartz, main fraction ≤ 0.1 mm, some 0.5-1 mm.

Type 141. Medium or Small Bowl

Similar to type 132 with slightly longer flange. The single example comes from a deposit of the late 1st – early 2nd century AD at Sāniat Jibril.

CMD No	Context	Other Information
949	GER 002 (3, 5)	Hard, light grey fabric

Type 142. Medium or Small Bowl

Small carinated bowl with short flange rim. Vessel 2815 comes from a context of the late 1st – early 2nd century AD. A similar vessel occurs at Sabratha (Dore and Keay 1989, Type 172) in a deposit of the late 2nd century AD.

CMD No	Context	Other Information
2815	GER 002 (2, 86)	
2614	GER 002 (4, 92)	

Fabric: Sandy orange-brown, dark grey surfaces with a cream wash or slip over the outer surface; inclusions: moderate rounded quartz, main fraction ≤ 0.1 mm, some up to 0.5 mm; sparse rounded lime, max of 0.5 mm.

Types 143 – 145: Small Carinated Bowls with Plain Rims**Type 143. Small Bowl**

The type is known at Sabratha (Dore and Keay 1989, Type 144) and in the pre-desert (Dore 1996, Type 122), though in the latter case usually in a finer red fabric. A case was made for dating the pre-desert type to the 4th century AD (Dore 1996, 386) whereas at least one of the Fazzān examples (2211) is likely to come from an earlier context (late 2nd-3rd century AD).

CMD No	Context	Other Information
2211	GER 002 (7, 2)	
3176	GER 002 (44, s)	

Fabric: Sandy dark grey, with darker slipped and burnished surfaces; inclusions: abundant rounded quartz, main fraction ≤ 0.1 mm, some 0.1-0.2 mm, occasional max of 0.5 mm

Type 144. Small Bowl

Similar to 143 though more restricted above the carination.

CMD No	Context	Other Information
3241	GER 002 (61, s)	
2730	GER 002 (g)	

Fabric: Sandy dark grey-brown with thin orange margins and banded grey and brown surfaces; smoothed surfaces; inclusions: moderate rounded quartz, main fraction ≤ 0.1 mm, some 0.5-1 mm.

Type 145. Small Bowl

This type may well have no formal connection with the previous two. It has a pronounced rebate above the carination and a generally upright upper wall. The type occurs in the pre-desert area (Dore 1996, Type 116) where one example was from a midden associated with a *qasr* (Mm 10) whose construction could be dated to after c.AD 200. Vessel [848] comes from a late 2nd- to 3rd-century context.

CMD No	Context	Other Information
3199	GER 002 (52, s)	
848	GER 001.4 (16)	
1336	GSC 002	
3343	GER 002	

Fabric: Sandy orange-brown with dark grey surface; white slipped band on the edge of the carination; traces of red ochre in the groove above the footring (vessel 3343); Sandy dark grey, with darker slipped and burnished surfaces (vessel 848); inclusions: abundant rounded quartz, main fraction ≤ 0.2 mm, max 0.5mm; some lime.

Type 146. Miscellaneous Bowl

Miscellaneous bowl imitating a glass form.

CMD No	Context	Other Information
133	ZIN 022 (South)	Fabric unknown

Types 147, 148, 149, 150, 151: Large and Medium Bowls and Dishes with Plain Rims**Type 147. Large Bowl**

The fabric is essentially an unslipped version of Tripolitanian Red Slip Ware (Hayes 1972, 304 ff.). The form (not dissimilar to TRS form 2) and certain features of its manufacture, the cut-away base and the use of knife-trimming on the upper part of the exterior wall, also suggest a relationship with that ware.

CMD No	Context	Other Information
3745	RUG 003	Hard metallic. Brownish sandy fabric; dark brown inner, blue green outside

Type 148. Large Bowl

CMD No	Context	Other Information
1961	GER 003 (160)	Sandy red-brown with grey core

Type 149. Medium Bowl

Bowl with plain, inturned lip. The formal characteristics of this type are extremely long-lived and thus not closely datable. At Berenice, Riley regards the form as 'essentially and primarily Hellenistic' (Riley 1979, 283: Hellenistic Plain Ware 4), though he notes that the general form was still being produced in a kiln at Tocra in the 3rd century AD. In the pre-desert area the form is likely to be a member of a coarseware series produced in parallel to Tripolitanian Red Slip Ware and to date to the 3rd century AD and later (see Dore 1996, Types 134-7).

CMD No	Context	Other Information
3164	GER 002 (33, s)	
3579	TIN 001 (B)	

Fabric: Sandy orange-brown with dark grey surfaces; outer surface smoothed and burnished; inclusions: moderate rounded quartz, main fraction 0.1-0.2mm, some 0.2-0.5mm, occasional max of 1mm.

Type 150. Medium Bowl

Bowl with plain, inturned lip. See remarks on type 146.

CMD No	Context	Other Information
2108	GER 003 (211)	Fabric unknown

Type 151. Medium Bowl

Bowl with plain, slightly inturned lip. The more open form of this type would suggest affinities with African and Tripolitanian Red Slip Ware types. Close parallels are known in the pre-desert area (Dore 1996, 385, Types 134 and 137). 3rd century AD or later.

CMD No	Context	Other Information
2904	CHA 001	
	GER 002 (7, 77)	Sandy, dark red
1213	GSC 008	Hard, dark red fabric, grey surface

Types 156 - 164: Medium and Small Bowls with Plain Rims**Type 156. Medium Bowl**

CMD No	Context	Other Information
1562	GSC 015	

Fabric: Sandy dark grey-brown with thin orange margins and banded grey and brown surfaces; smoothed surfaces; inclusions: moderate rounded quartz, main fraction ≤ 0.1 mm, some 0.5-1mm.

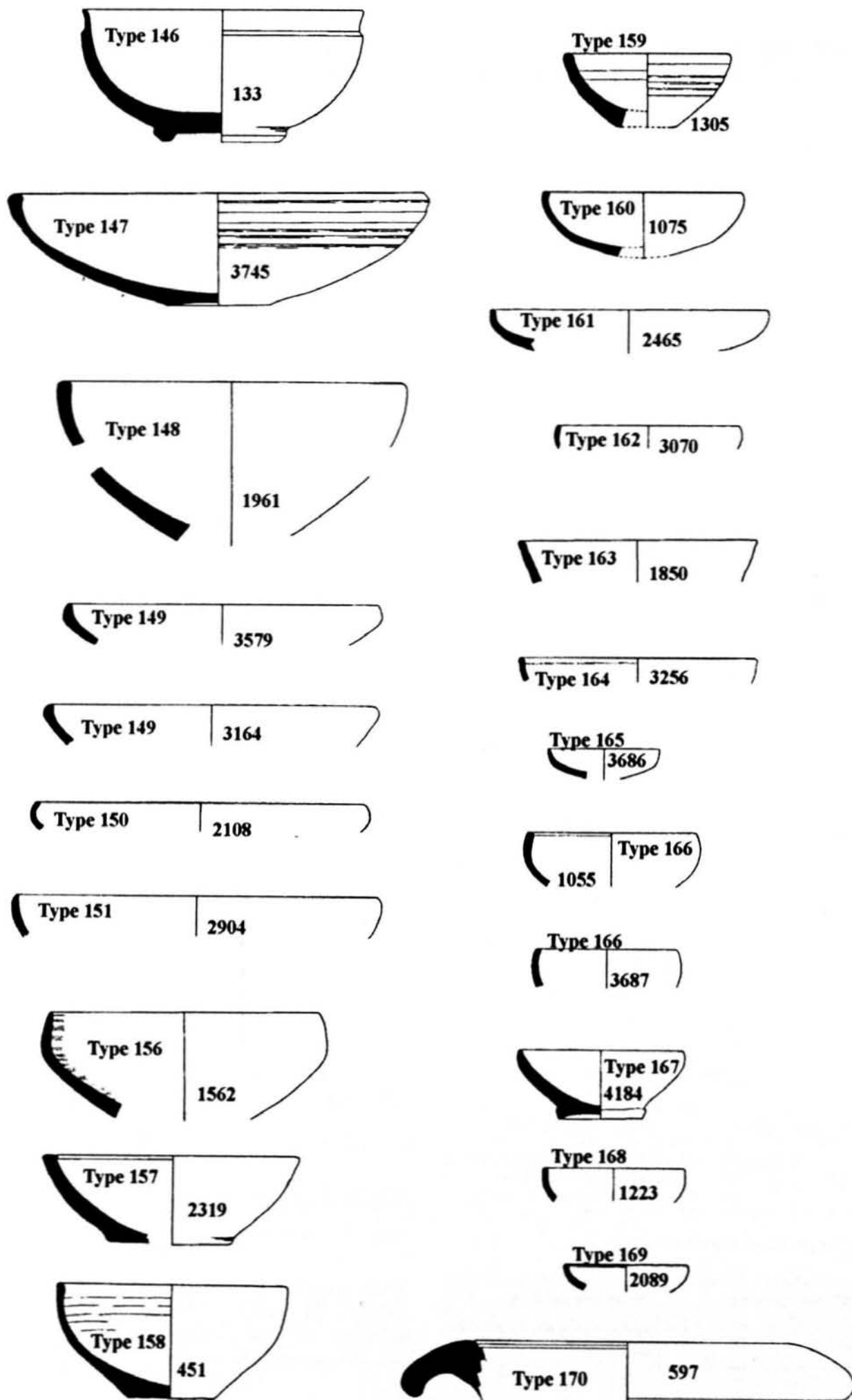

Figure 41.26. Coarseware types 146-170. 1:4.

Type 157. Medium Bowl

Miscellaneous bowl. The single example is from a context dating to the later 2nd – 3rd century AD.

CMD No	Context	Other Information
2319	GER 002 (6, 2)	Sandy dark grey, with darker surfaces; inner surface once burnished

Type 158. Medium Bowl

Miscellaneous bowl.

CMD No	Context	Other Information
451	FJJ 004	Reddish sandy brown fabric, smoothed, no slip

Type 159. Small Bowl

Miscellaneous bowl.

CMD No	Context	Other Information
1305	GSC 002	Hard brown fabric, with black outer surface

Type 160. Small Bowl

Miscellaneous bowl.

CMD No	Context	Other Information
1075	GSC 008	Red fabric, black inside

Type 161. Small Bowl

Miscellaneous bowl. Vessel [2465] is from a context dating to the later 2nd-3rd century AD at Sāniat Jibril.

CMD No	Context	Other Information
1983	CHA 001	
2465	GER 002 (2, 33)	Sandy brown with darker surface

Type 162. Small Bowl

Miscellaneous bowl. The single example is from a context possibly dating to the early 4th century AD.

CMD No	Context	Other Information
3070	GER 002	Unslipped sandy red

Type 163. Small Bowl

Miscellaneous bowl.

CMD No	Context	Other Information
1850	GER 001.3 (1)	Unslipped reddish-brown with grey core

Type 164. Small Bowl

Miscellaneous bowl.

CMD No	Context	Other Information
3256	GER 002 (69, s)	Sandy dark grey, with darker surfaces; inner surface once burnished

Types 165, 166, 167, 168, 169: Small bowls or cups with plain rim

Most of these vessels have been re-examined and are known to be coarseware.

Type 165. Small Bowl or Cup

CMD No	Context	Other Information
3686	TIN 001 (B)	Dark fabric

Type 166. Small Bowl

CMD No	Context	Other Information
1055	GSC 008	Sandy reddish-buff fabric, smooth surface
3687	TIN 001 (B)	Dark fabric

Type 167. Small Bowl or Cup

CMD No	Context	Other Information
4184	GSC 020	Hard buff fabric, darker brown outer surface

Type 168. Small Bowl or Cup

CMD No	Context	Other Information
1223	GSC 008	Dark brown fabric, grey outer surface, almost black inner

Type 169. Small Bowl or Cup

CMD No	Context	Other Information
2089	GER 001.4 (211)	Fabric unknown

Mortarium

Type 170. Mortarium

CMD No	Context	Other Information
597	ZIN 109 (10)	

Fabric: Gritty, dull pinkish-brown, smoothed surfaces; inclusions: abundant, angular quartz, main fraction 0.5-1mm; moderate angular rock fragments, main fraction ≤ 2 mm; abundant angular black vitreous grains, main fraction ≤ 2 mm; abundant, rounded quartz, main fraction ≤ 0.2 mm.

Casseroles, Basins and Jars

Type 171. Casserole

This type has a general similarity to Sabratha types 33 and 34 (Dore and Keay 1989) indicating a date range of 3rd century BC to 1st century AD.

CMD No	Context	Other Information
3150	GER 002 (29, s)	
3207	GER 002 (54, s)	

Fabric: Sandy dark grey, with darker surfaces; burnished outer surface.

Type 171.1. Casserole

See Sabratha Type 15 (Dore and Keay, 1989). 1st century AD.

CMD No	Context	Other Information
2084	GER 001.5/6/7	

Type 172. Casserole

See Sabratha Type 46 (Dore and Keay 1989). Late 1st-3rd century AD.

CMD No	Context	Other Information
3969	GER 001.5/6/7	

Type 173. Casserole

This type seems to constitute the principal casserole type in use in central and southern Tunisia and Tripolitania during the mid-Roman period. It was almost certainly produced at, or in the immediate vicinity of, Leptiminus (see Dore 1992, Type 13), and also at kilns sites in Tripolitania, on the evidence of Sidi al-Sid (Arthur 1982). The type occurs in quantity at Sabratha (Dore 1989, Types 58-60) where it appears in the second half of the

2nd century AD and continues throughout the 3rd and 4th centuries. It also occurs in the pre-desert area (Dore 1996, Types 62-4) in association with fineware which confirms a starting date in the 2nd century AD.

CMD No	Context	Other Information
3292	GER 002 (112, s)	
3103	GER 002 (3, s)	
3252	GER 002 (63, s)	
3194	GER 002 (51, s)	

Fabric: Sandy red-brown, with red inner surface and dark grey outer surface; the outer surface is covered with a cream-brown slip and finished with narrow burnished horizontal bands; inclusions: abundant rounded quartz, main fraction ≤ 0.1 mm, some 0.1-0.2mm, a little 0.2-0.5mm, occasional max of 1mm; sparse rounded lime, main fraction ≤ 0.2 mm, occasional max of 0.5

Type 174. Casserole

Variant of type 174.

CMD No	Context	Other Information
1823	GER 001.3 (15)	R8 sandy red

Type 175. Casserole

Finer, thin-walled version of casserole type 173. Occurs at Sabratha (Dore and Keay 1989, Type 65) and in the pre-desert (Dore 1996, Type 68). Its distribution suggests that it was produced in Tripolitania. The evidence from Sabratha and the pre-desert suggests that the type started being produced in the 3rd century AD and continued at least into the 5th century.

CMD No	Context	Other Information
947	GER 002 (2, 5)	R7
3873	GRE 001	Dark fabric, sandy, hard

Type 176. Casserole

The classic northern Tunisian casserole form (see Hayes 1972, Form 197) which started in the later 2nd century AD and continued, with some evolution, until the early 5th century. The fabric of both these pieces is that known, after Hayes, as African Black Top Ware (Hayes 1976, 87).

CMD No	Context	Other Information
2426	GER 002 (4, 49)	
2227	GER 002 (7, 2)	

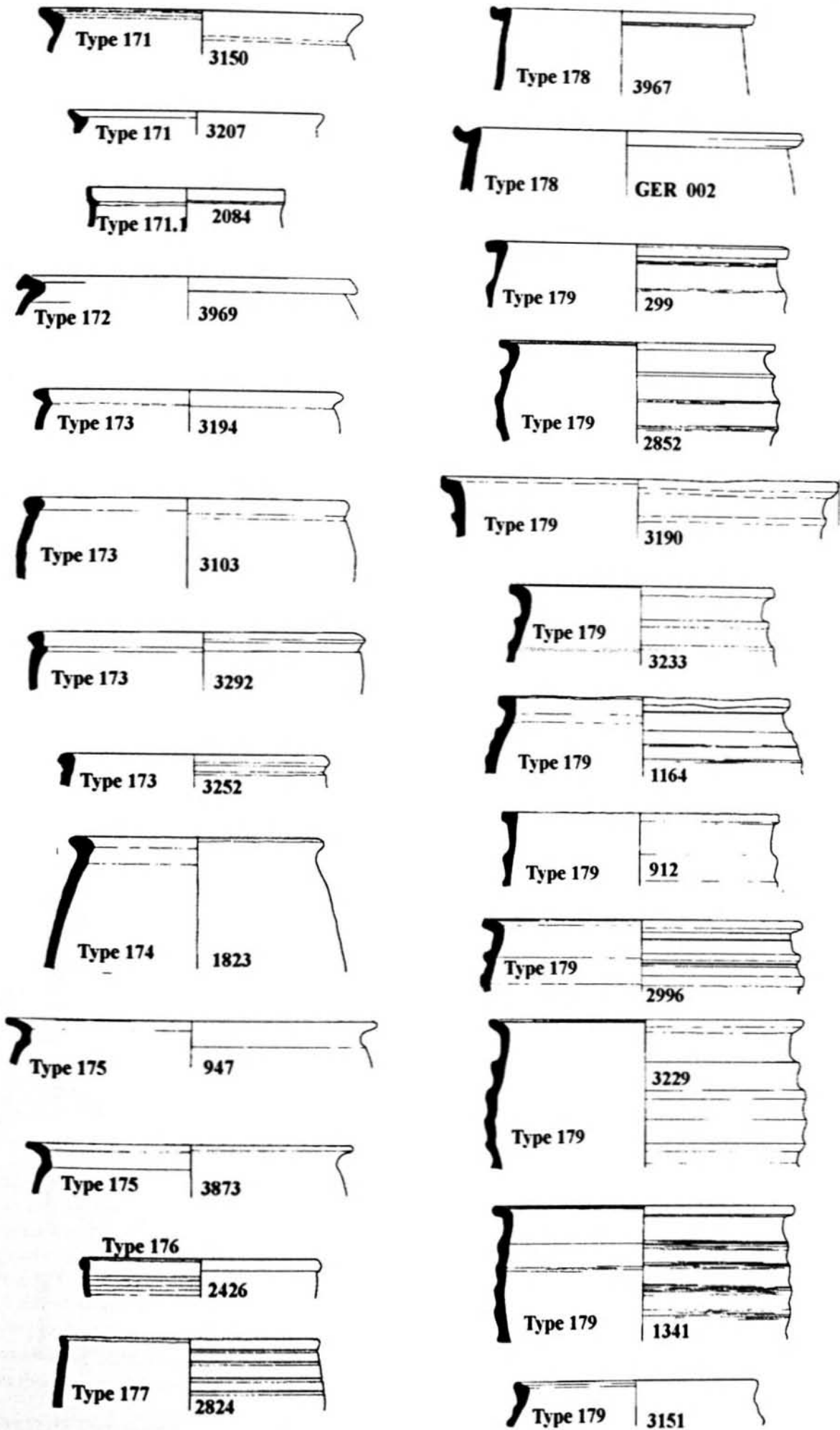

Figure 41.27. Coarseware types 171-179. 1:4.

Type 177. Casserole

Related to type 176 but quite probably slightly earlier. See Sabratha Type 55 (Dore and Keay 1989). The fabric is similar to African Black Top Ware.

CMD No	Context	Other Information
2824	GER 002 (6, 24)	

Fabric: Sandy orange-brown, with dark grey surfaces; thin horizontal wet-burnished bands on the outer surface; inclusions: moderate rounded quartz, main fraction 0.1-0.2mm, occasional max of 1mm.

Type 178. Casserole

Casserole with upturned (that is, lid-locating) flange rim. This type is common in Cyrenaica (Benghazi (Berenice) MR Cooking Ware 1) where a kiln site is known at Tocra. Riley (1979) dates its introduction at Berenice to the end of the 1st or beginning of the 2nd century AD, and it seems to have lasted there until the 5th century AD. The type also occurs at Bū Nijīm where it was the principal casserole form (Rebuffat *et al.* 1970) and in the pre-desert (Dore 1996, Type 67). The pre-desert area and Jarma seem to mark the westernmost limit of the type's distribution.

CMD No	Context	Other Information
3967	GER 001.5/6/7	
	GER 002 (D, g)	

Fabric: Fine, dark reddish-brown with red-brown inner surface and dark grey outer surface; the surfaces are smoothed; inclusions: moderate rounded quartz <=0.2mm.

Type 179. Casserole

A distinctive, deep casserole whose walls are covered with parallel, equally spaced horizontal ridges. The rim consists, for the most part, of a simple, slightly uptilted flange which, in some examples, is slightly relieved to form a lid-locator, though examples are known with a bead and flange rim (GER 001, G1, 924 – mud-brick packing, phase 7). Within the Wādī al-Ajāl, the type appears to be restricted to Jarma and its immediate environs (GSC 002 and 003). No close parallels are at present known outside the region, though it may be noted that horizontal ridging as a general decorative technique is a characteristic of mid-Roman cooking wares at Berenice (Riley 1979, fig. 104). The fabric suggests an origin within the region and it may well be that the type was produced in the locality.

CMD No	Context	Other Information
3151	GER 002 (29, s)	
299	GER 002 (1, 4)	Phase 1

3190	GER 002 (48, s)	
3229	GER 002 (59, s)	
912	GER 002 (g)	
2996	GER 002 (g)	
3233	GER 002 (60, s)	
2852	GER 002 (1, 9)	Phase 2
1341	GSC 002	
1164	GSC 003	

Fabric: Sandy orange-brown, with dark grey surfaces; horizontal wet-burnished bands on the outer surface; inclusions: moderate rounded quartz, main fraction 0.1-0.2mm, occasional max of 1mm.

Type 179.1. Casserole

This is an example of the most commonly occurring casserole type in the Tripolitanian pre-desert. The fabric is likely to be a coarser version of Tripolitanian Red Slip Ware (see Dore 1996, Types 69-72, and p. 374 for a discussion of the dating evidence). 4th – 5th centuries AD (and possibly later).

CMD No	Context	Other Information
422	GER 001 (5)	Sandy red

Types 180-186. Deep Casseroles

The superordinate type of which 180-186 are all variants is a deep casserole or basin with a more or less upright upper wall. Types 180 and 181 are distinguished by rims with a lid-locator in their back face; type 180 has a short flange rim of angular sectional profile, type 181 a shorter rim of more amorphous profile. The rim of type 183 has a barely articulated flange and a single groove cut in its top edge.

Within Wādī al-Ajāl, the majority of recorded occurrences are at Sāniat Jibril (GER 002) where four examples were recovered from contexts of Phase 1. Single examples are also recorded from TWE 015 and GBD 001. A vessel of similar form is known from Sabratha (Dore and Keay 1989, fig. 49, no. 188), where it occurs in a context with a likely date range 2nd century BC-early 1st century AD.

Fabric: This is usually a sandy dark grey, less often orange-brown or red-brown. Grey examples sometimes have an orange-brown core. The surfaces are mostly dark grey. The treatment of the outer surface varies. Some examples show the remains of a cream slip, though it may well be that many examples were once treated in this way. Many examples, whether slipped or not, have their outer surface burnished in narrow, horizontal, parallel bands. Occasional examples have a good burnish on both their

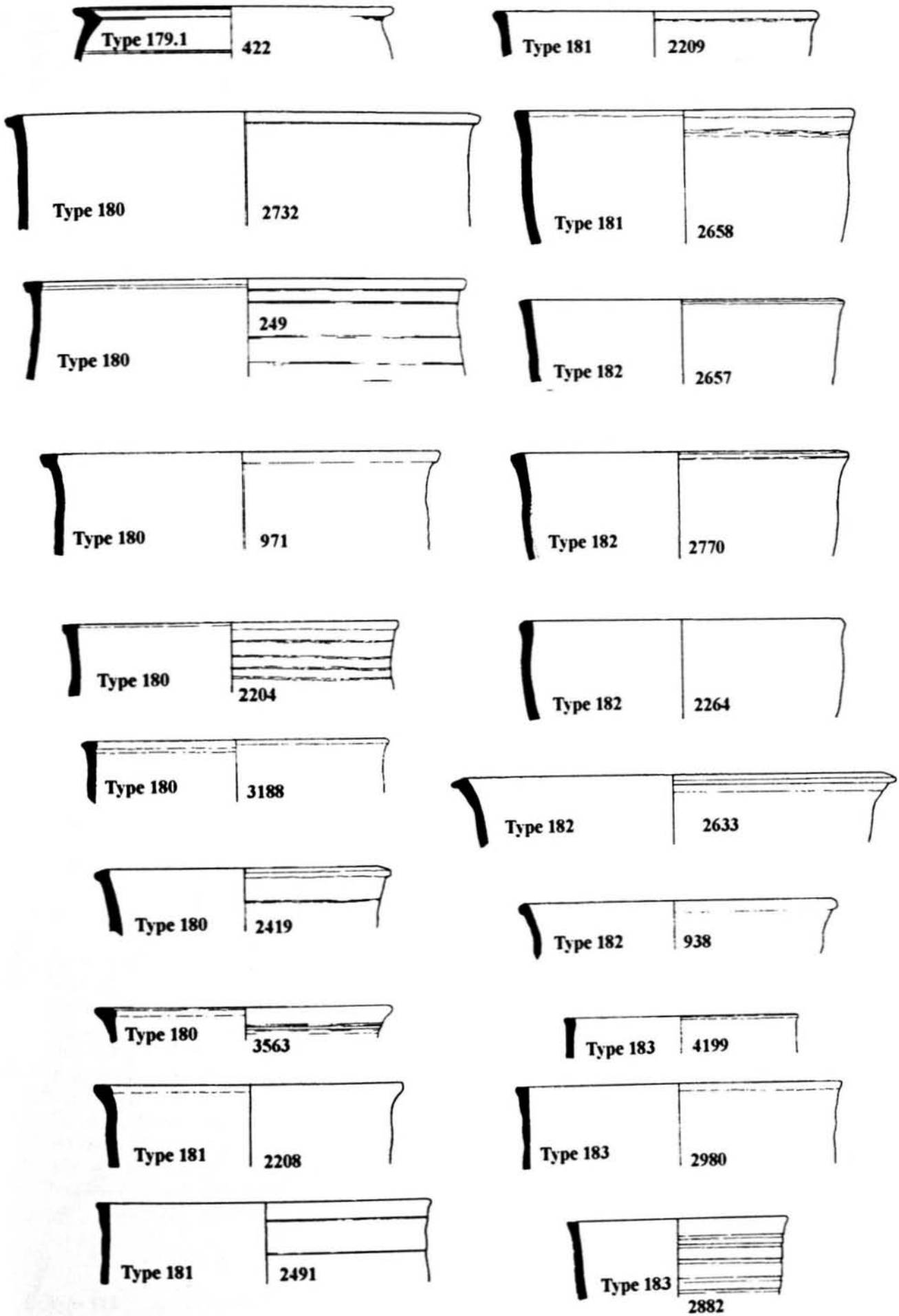

Figure 41.28. Coarseware types 179.1-183. 1-4.

inner and outer surfaces and the quality of this is such as to suggest that they may have been slipped before burnishing. The appearance of this particular fabric variant is very close to Tripolitanian Red Slip Ware. A single example with a red-brown fabric has an even, matt black smoothed and slipped surface. Inclusions: abundant rounded quartz, main fraction ≤ 0.2 , some 0.2-0.5, occasional grains up to 1.0mm. Some examples have sparse grains of rounded limestone up to 0.3mm.

Type 180. Casserole or Basin

CMD No	Context	Other Information
3563	GBD 001	
2419	GER 002 (4, 18)	
971	GER 002 (4, 4/1)	
2204	GER 002 (6, 1)	
249	GER 002 (4, s)	
3188	GER 002 (118, s)	
2732	GER 002 (g)	

Type 181. Casserole or Basin

CMD No	Context	Other Information
2209	GER 002 (4, 10)	
2658	GER 002 (6, 9)	
2491	GER 002 (2, 29)	Phase 3
2208	GER 002 (4, 10)	

Type 182. Casserole or Basin

CMD No	Context	Other Information
938	GER 002 (1, 2)	Phase 1
2657	GER 002 (6, 9)	Phase 2
2264	GER 002 (4, 11)	
2770	GER 002 (6, 24)	Phase 1
2633	GER 002 (6, 12)	Phase 1

Type 183. Casserole or Basin

CMD No	Context	Other Information
2980	GER 002 (7, 29)	Phase 3

CMD No	Context	Other Information
2882	GER 002 (6, 24)	Phase 1
4199	TWE 015	

Type 184. Casserole or Basin

CMD No	Context	Other Information
2802	GER 002 (6, 23)	Phase 1

Type 185. Casserole or Basin

CMD No	Context	Other Information
3158	GER 002 (30, s)	

Type 186. Casserole or Basin

CMD No	Context	Other Information
3203	GER 002 (54, s)	

Type 187. Casserole or Large Bowl

Casserole or large bowl, moulded rim. Single example.

CMD No	Context	Other Information
3162	GER 002 (32, s)	Light brown with grey core and darker surface

Type 188. Casserole or Large Bowl

Casserole or large bowl. Single example.

CMD No	Context	Other Information
2200	GER 002 (4, 10)	

Type 189. Casserole

Casserole or deep bowl with thickened rim. Single example. Examples of this type have been noted at Leptiminus from undated field survey contexts (the precise type has not been published, though a similar type appeared in Dore 1992, no. 20) and may have been manufactured there (though it does not appear in any of the groups published by Peacock *et al.* (1989 and 1990). A very similar type occurs at Carthage (Fulford and Peacock 1984, Type 13) and is thought to have been produced in the Cathage-Nabeul region (Fulford and Peacock 1984, Type 14). The type appears in contexts at Cathage dated to the second half of the 6th century AD.

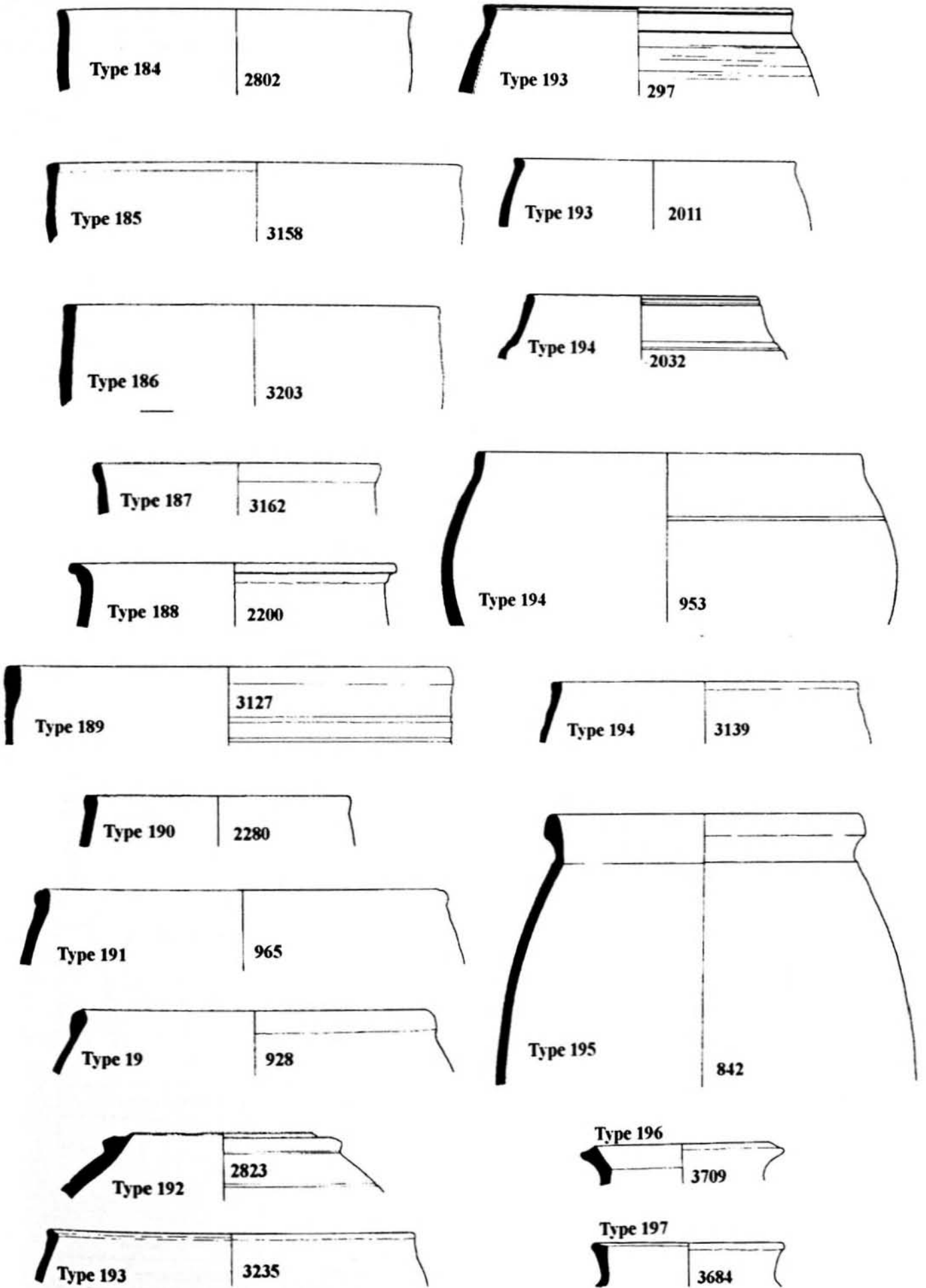

Figure 41.29. Coarseware types 184-197. 1:4.

CMD No	Context	Other Information
3127	GER 002 (24, s)	Sandy red with dark slip

Types 190 – 194. Casseroles or Large Jars with Restricted Mouths.

Type 190. Casserole or Large Jar

CMD No	Context	Other Information
2280	GER 002 (6, 4)	

Fabric: Sandy dark grey, dark grey-black surfaces; surfaces (certainly the inner) originally burnished.

Type 191. Casserole or Large Jar

CMD No	Context	Other Information
965	GER 002 (4, 4/1)	Sandy grey
928	GER 002 (1, 2)	Orange-brown with red slip

Type 192. Casserole or Large Jar

The single example comes from a context dating to the late 2nd-3rd century.

CMD No	Context	Other Information
2823	GER 002 (4, 74)	

Fabric: Sandy orange-brown, reddish-brown core, dark grey outer surface. Smoothed and burnished outer surface. Inclusions: abundant rounded quartz, main fraction 0.1-0.2mm, some 0.2-0.5mm, occasionally up to 1.5mm; sparse rounded lime, main fraction 0.1-0.3mm.

Type 193. Casserole or Large Jar

Vessel [297] comes from a context of the late 2nd-3rd century AD.

CMD No	Context	Other Information
297	GER 002 (4, 2/2)	Grey with red core; slipped.
3235	GER 002 (60, s)	Black with red core.
2011	GER 002 (g)	Sandy reddish-purple.

Type 194. Casserole or Large Jar

The type specimen, vessel [2032] comes from a context (GER 001.4 (24, 1)) of the late 2nd-3rd century AD.

CMD No	Context	Other Information
953	GER 002 (4, 4/1)	

CMD No	Context	Other Information
3139	GER 002 (28, s)	
2032	GER 001.4 (24, 1)	

Fabric: Sandy orange-brown, with dark grey surfaces; there is a cream wash or slip over the outer surface; inclusions: moderate rounded quartz, main fraction <=0.1mm, some 0.1-0.2mm, occasionally up to 0.5mm; sparse rounded lime up to 0.5mm

Types 195 – 203. Jars

Type 195. Jar

This vessel appears very similar to jars in Pantellerian ware (see Dore and Keay 1989, fig. 61, nos 291 and 292). This identification cannot be verified, however, since none of the authors have seen the piece. The fabric description given in the original field notebook is equivocal.

CMD No	Context	Other Information
842	GER 001.4 (8)	Dark brown with black surface

Type 196. Jar

CMD No	Context	Other Information
3709	TIN 001 (B)	
3611	TIN 001 (B)	

Fabric: Gritty red-brown, smoothed black surfaces; inclusions: moderate rounded quartz, main fraction <=0.1mm, some 0.1-0.2mm, a little 0.2-0.5mm; sparse rounded lime up to 0.5mm.

Type 197. Jar

CMD No	Context	Other Information
3684	TIN 001 (B)	Grey fabric, brownish surface, probably not slipped

Type 198. Jar

CMD No	Context	Other Information
604	ZIN 109 (11)	Light buff

Type 199. Jar

CMD No	Context	Other Information
578	ZIN 109	No fabric description

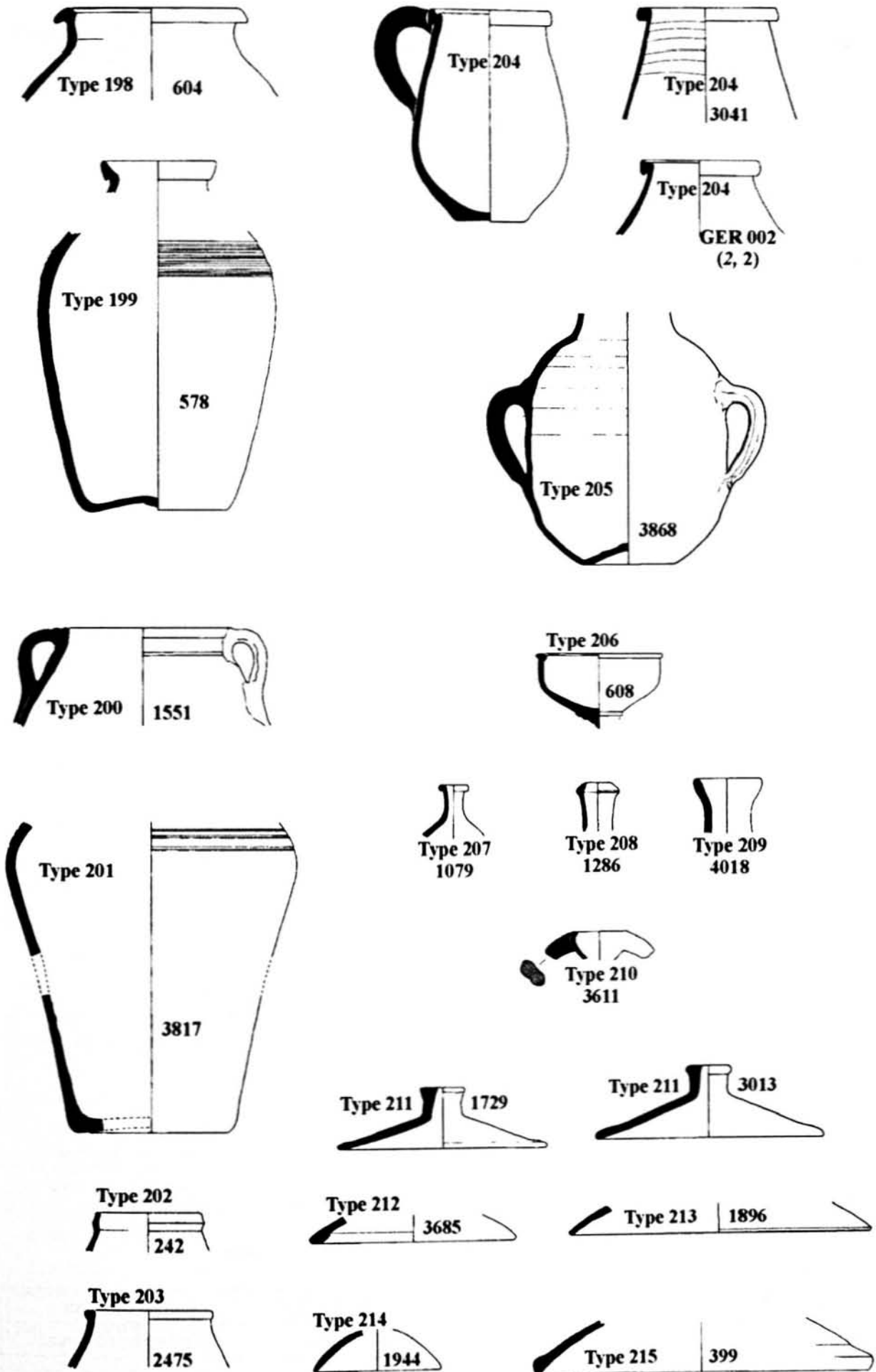

Figure 41.30. Coarseware types 198-215. 1:4.

Type 200. Jar

CMD No	Context	Other Information
1551	ZIN 109 (G)	Metallic brown-red

Type 201. Jar

CMD No	Context	Other Information
3817	LEK 009 (G)	

Type 202. Jar

Small jar or flask.

CMD No	Context	Other Information
242	GER 002 (4, 5/4)	

Fabric: Sandy orange-brown, dark grey surfaces, burnished outer surface; inclusions: moderate rounded quartz, main fraction 0.1-0.2mm, some up to 0.5mm, occasional max of 1mm.

Type 203. Jar

Small jar. The single example comes from a context which dates to the late 1st or 2nd century AD.

CMD No	Context	Other Information
2475	GER 002 (6, 14)	CC4

Fabric: Sandy orange-brown, dark grey surfaces, burnished outer surface; inclusions: moderate rounded quartz, main fraction 0.1-0.2mm, some up to 0.5mm, occasional max of 1mm.

Types 204 – 206: Mugs and Feeders**Type 204. Mug**

A small bag-shaped mug or jug usually with a single handle. Vessels of this type have been found on sites all along the Tunisian and Tripolitanian coasts: Carthage (ER Jugs 1 and 2; for examples from well-dated contexts see Tomber 1986, and also Fulford 1994, 70, Type 3 the earliest occurrence of which is dated to the second half of the 1st century AD), Uzita (Van der Werff 1982, pl. 27 for a particularly good example), Leptiminus (Dore 1992, no. 86), Sabratha (Dore and Keay 1989, particularly Type 350). At Sabratha, many examples were recovered from excavations of the tophet and are on display in the Punic Museum (Brecciaroli-Taborelli 1983 has a report on the salvage excavation; there has been no publication, so far as we are aware, of the pottery). Examples have been noted (by Dore) in the museum of Lepcis Magna from contexts (mostly funerary) between Lepcis and Miṣurāta. They also

occur in the pre-desert area (Dore 1996, Type 37 and 38). Overall, the available evidence suggests that the form was common in the 2nd to 3rd centuries AD. The typical fabric described below is the same as the typical fabric in which the principal 2nd- to 4th-century Tripolitanian casserole type (our Type 173) occurs.

CMD No	Context	Other Information
3041	CHA 001	
[H14]	GER 011 (T A3.3)	
	GER 002 (2, 2)	
[H188]	GER 011 (T A3.3)	

Fabric: The typical fabric is that in which the example from GER 002 (2, 2), below, appears: sandy orange-brown, orange core with thin dark-grey margins; cream-brown slip on outer surface; inclusions: abundant, rounded quartz all c.0.1mm; sparse, rounded limestone up to 0.6mm.

Type 205. Feeder

Two-handed flask or feeder, or possibly a miniature model of an amphora. A very similar vessel is known from Mausoleum 1 in the Roman Cemetery of Puppūt, close by modern Hammamet, Tunisia (Bonifay 2004, 222). Bonifay regards the Puppūt example as a representation of one of three types of amphora 'de tradition punique' manufactured in the Hammamet area and notes, 'Le dépôt de céramiques miniatures dans les nécropoles puniques et néo-puniques est un phénomène bien documenté' (Bonifay 2004, 222, n. 56).

CMD No	Context	Other Information
3868	GRE 001	

Type 206. Cup

Small stemmed cup. The break on the base suggests that this vessel was originally attached to a more extensive structure.

CMD No	Context	Other Information
608	ZIN 109 (4)	Red, hard, well-made

Types 207 – 210. Unguentaria**Type 207. Unguentarium**

CMD No	Context	Other Information
1079	GSC 008	Light fabric, buff ware

Type 208. Unguentarium

CMD No	Context	Other Information
1286	GSC 008	Buff fabric

Type 209. Unguentarium

CMD No	Context	Other Information
4018	LEK 006	Black fabric, red core

Type 210. Unguentarium

CMD No	Context	Other Information
3611	TIN 001 (BE)	Sandy, pink fabric, yellow slip

Types 211-214. Lids**Type 211. Lid**

CMD No	Context	Other Information
1729	FJJ 004	Red sandy brick fabric
3013	FJJ 004	Dark fabric

Type 212. Lid

CMD No	Context	Other Information
3685	TIN 001 (B)	Dark inside, black outside

Type 213. Lid

CMD No	Context	Other Information
1896	GER 001.3 (1)	Reddish-brown with grey core

Type 214. Lid

CMD No	Context	Other Information
1944	GER 003 (152)	Hard, metallic, dark purplish red with brown core

Type 215. Lid

The fabric of this vessel occurs at Carthage where it is known as Early Roman Cooking Ware and African Black Top Ware (see Hayes 1976, 87, 93).

CMD No	Context	Other Information
399	GER 001.4 (12)	

Fabric: Gritty orange with orange-yellow surfaces; the lip and moulding of the rim are black; the inner surface has been wiped, the outer surface knife-trimmed; inclusions: moderate rounded quartz, main fraction 0.1-0.2mm, a little 0.2-0.6mm; sparse rounded black iron rich, occasional max of 0.2mm; sparse rounded lime, occasional max of 1mm.

Types 216 and 217. Pedestal vases**Type 216. Pedestal Vase**

This is a highly distinctive vessel class. The general form is that of an inverted bell-shape with a pedestal foot. The rim consists of a short, plain flange which, in the case of 236, is barely articulated from the upper wall. There is generally a clearly demarcated undecorated band just below the rim. Decoration consists of: a) parallel, horizontal cordons; b) impressions, often of date-stones, but with various other motifs also represented. There appears to be a case for seeing these forms as copying a similar form in Italian terra sigillata. The similarity between the vessel H51 from Ayoub's excavation of Sāniat bin Huwaydī and some of the contemporary Italian designs is striking. In particular we might note that form R9.2.1 (illustrated by Kenrick in *Conspectus Formarum*, Tafel 58, p. 178) bears a wheel-like motif that seems to be exactly matched by vessel H51.

CMD No	Context	Other Information
2001	GER 003 (200)	
[H51]	GER 011 (T A3.1)	
463	UAT 016	
1296	ZIN 115 (S)	
1091	ZIN 220 (g)	
263	ZIN 001 (s)	

Fabric: The fabrics in which these vessels were manufactured are extremely diverse. The example from Zinkekra [263] is in a very heavy fabric that seems to be related to the amphora fabrics of amphora classes 2-4. In contrast, that from Waṣwāt [463] is in a much lighter fabric that appears very similar to the local handmade Berber Red Wares. A fragmentary example of a wall-sherd from Jarma, which bears the date-stone impressions, but which need not come from a pedestal vase, is in a much softer purer fabric, very much like those of Italian wine amphorae of the 1st century BC and AD.

The dating of these vessels is unfortunately not as precise as we might wish, but better than for other vessels. Vessel [H51] comes from tomb A3.1 at Sāniat bin Huwaydī dug by Ayoub, and was found in association with Italian Sigillata dishes stamped by the workshop of L. Rasinius Pisanus, dating to the mid to late 1st century AD.

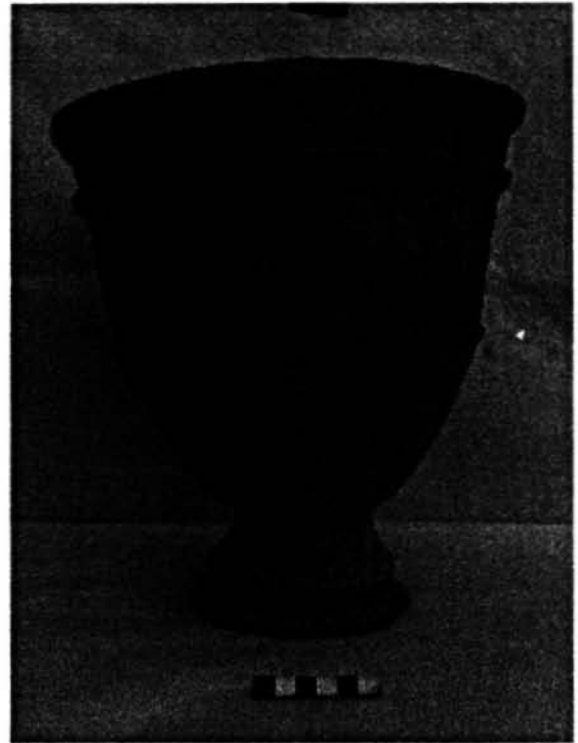
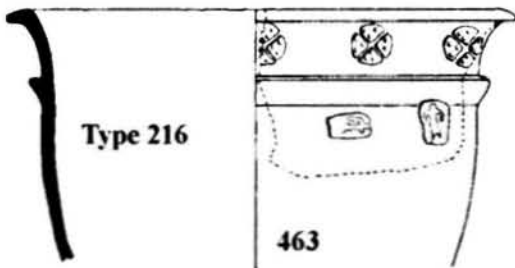
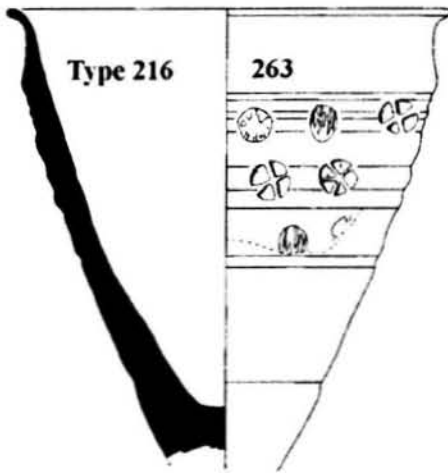
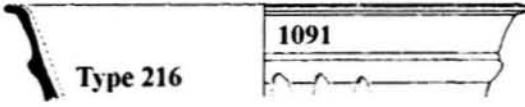
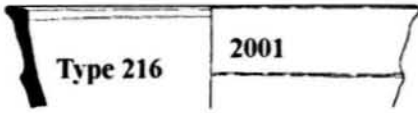

Figure 41.31. Coarseware types 216-217. 1:4.

The parallels in the chalice series of relief moulded Italian wares date to as late as the Claudian period (*Conspectus Formarum*, 178), suggesting that these vessels were being produced around the middle of the 1st century AD.

Type 217. Pedestal Vase

Pedestal feet probably to be associated with type 216.

CMD No	Context	Other Information
2560	GER 002 (6, 18)	
288	ZIN 296	

Types 218-238. Flagons and Jugs

Type 218. Amphoroid Flagon

This type (along with types 219-220) could be a further example of the small 'amphoroid' forms discussed under amphora types 6-8. Generally speaking, they are thinner walled and narrower necked than these types and have therefore been placed in the flagon category. Parallels are given with the amphora types. Date: 1st - 2nd century AD.

CMD No	Context	Other Information
6004	GER 001.3	
6040	GER 001.3	
6029	GER 001.3	
6037	GER 001.3	
6033	TIN 001 (B, 17, s)	

Fabric: Two fabrics seem to be represented by the examples below.

1. Red-brown with black surfaces; this fabric can be quite fine - ie with abundant rounded quartz, all of which is ≤ 0.1 mm, and a little rounded lime, 0.1-0.3mm - or it can be somewhat coarser - with abundant rounded quartz, main fraction 0.1-0.3mm, a little 0.4-0.6mm, and an occasional max of 1.5mm, and little or no lime.

2. Fine dull orange-brown with a cream slip on the outer surface; inclusions: sparse angular black vitreous grains, main fraction 0.2-0.5mm in a silty matrix containing very fine lime.

Type 218.1. Amphoroid Flagon

A type which occurs frequently in the Tripolitanian pre-desert where the evidence suggests a date in the range 1st - 3rd century AD (Dore 1996, 361, Type 33).

CMD No	Context	Other Information
1192	GSC 004	
4198	TWE 011	

CMD No	Context	Other Information
619	ZIN 109 (11)	

Fabric: Sandy orange-buff with traces of a cream slip on the external surface.

Type 219. Amphoroid Flagon

CMD No	Context	Other Information
3374	GER 002 (4, 120)	
4197	TWE 011	

Fabric: Sandy orange-brown, cream-brown surfaces; inclusions: abundant rounded quartz, main fraction ≤ 0.1 mm, occasional max of 0.5mm; moderate rounded lime, main fraction ≤ 0.1 mm.

Type 220. Amphoroid Flagon

CMD No	Context	Other Information
1984	CHA 001	
1994	CHA 001 (G)	
	FJJ 006	
3006	FJJ 006	
2232	GER 002	
1151	GSC 002	
1159	GSC 002 (G)	
1313	GSC 005 (g)	
677	ZIN 001-003	

Fabric: These examples are all in a lime-rich fabric. Sandy orange-brown, yellowish-cream slip on outer surface; inclusions: moderate to abundant rounded lime, main fraction 0.1-0.5mm, some 0.5-2.0mm.

Type 221. Flagon

There is a close parallel for this type, both in form and fabric, in the pre-desert (Dore 1996, fig. 47.5). Occurrences of the type in the pre-desert are almost entirely confined to late sites and suggest a date not earlier than the late 3rd century AD.

CMD No	Context	Other Information
3818	LEK 009 (G)	
3712	TIN 001 (B, 5)	
3711	TIN 001 (B, Y)	
6031	TIN 001 (B, Y)	

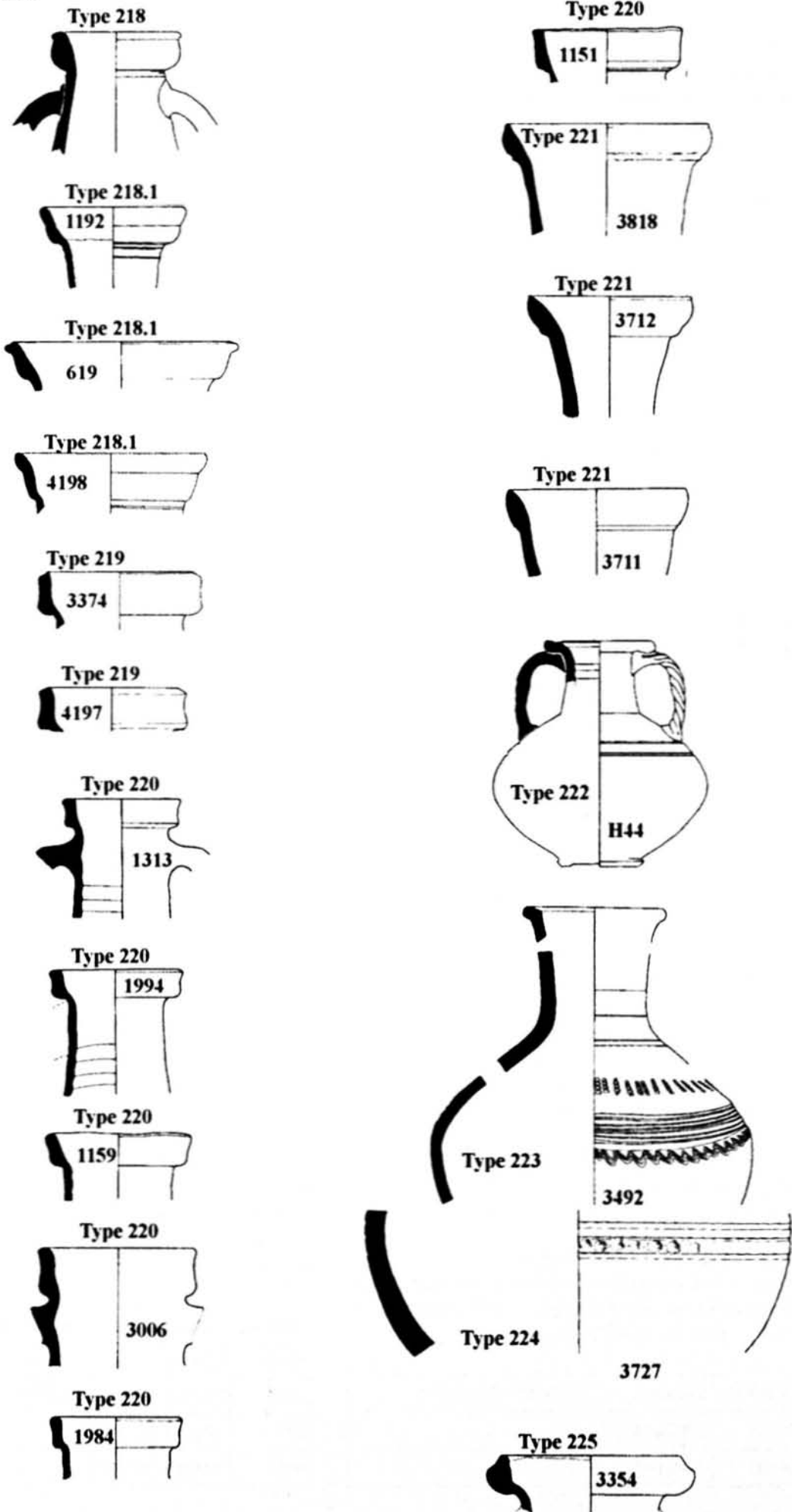

Figure 41.32. Coarseware types 218-225. 1:4.

Fabric: Sandy red-brown, black surfaces; inclusions: abundant rounded quartz, main fraction ≤ 0.1 mm, a little 0.2-0.3 mm, occasional max of 0.5 mm; sparse rounded lime, main fraction 0.2-0.5 mm.

Type 222. Flagon

Two-handled flagon or flask with ovoid body. A vessel of this type is known from a tomb on the coast near Lepcis Magna (unpublished, in Lepcis Magna museum). Rim sherds which are very likely to be from the type occur in the pre-desert area (Dore 1996, Type 40). The fineware associations in the pre-desert do not allow any close dating of the type but general considerations would suggest that it is early, that is, 1st-2nd century AD. With the exception of [H44], which was seen in January 2000 in Jarma Museum, our only information concerning these vessels comes from the Sabhā Museum catalogue and Daniels' archive photographs.

CMD No	Context	Other Information
[H44]	GER 011 (TA2.2)	Pale buff fabric with glossy burnish on exterior surface
[H21]	GER 011 (TA2.4)	Light red fabric One handle is broken off
[H43]	GER 011 (TA3.1)	Grey fabric, brown slip in places, smoothed outer surfaces, slight gloss. Blackened in places
3048	FUG 004	Hard red fabric

Type 223. Flagon

CMD No	Context	Other Information
3492	ZOU 006	Fabric unknown

Type 224. Flagon

Sherd from the globular body of a large flagon.

CMD No	Context	Other Information
3727	RUG area	Sandy, dark fabric with red surface; outer surface has a lighter, yellow-brown slip

Type 225. Flagon

The bead and flange rim of this type seems to be characteristic of the Mid-Roman period (see Dore and Keay 1989, fig 66, no. 344 and fig. 67, no. 369 both from contexts of the 2nd century AD).

CMD No	Context	Other Information
3354	GER 002 (8, 10)	

Fabric: Sandy orange-brown, dark grey surfaces;

inclusions: moderate rounded quartz, main fraction 0.1-0.2 mm; some 0.2-0.5 mm, occasional max of 1 mm

Type 226. Flagon

The type occurs at Carthage (Fulford 1984, fig. 80, Type 24), Uzita (Van der Werff 1982, pl. 11, no. 18), Sabratha (Dore and Keay 1989, fig 67, Type 361), and in the pre-desert (Dore 1996, fig. 47.5, Types 49 and 50). The context at Uzita could be as early as the late 1st century AD. One of the contexts in the pre-desert (Type 49 from the midden of *qasr* Mm 10) has a *TPQ* of c. AD 200. The occurrence cited at Carthage, in contexts dating from the mid 5th to the early 6th century AD, is likely to be residual. Suggested date range 2nd-4th century AD.

CMD No	Context	Other Information
3558	GEL 004	
2526	GER 002 (4, 120)	
3666	TIN 001 (A, 103, s)	

Fabric: Sandy red-brown, smoothed black surfaces; inclusions: moderate-abundant rounded quartz, main fraction ≤ 0.1 mm, a little 0.2-0.3 mm, occasional max of 0.5 mm; sparse rounded lime, main fraction 0.2-0.5 mm

Type 227. Flagon

CMD No	Context	Other Information
3542	ZOU 002	Brownish fabric

Type 228. Flagon

Mid-Roman? Similar to Benghazi form 1146 (Riley 1979).

CMD No	Context	Other Information
6036	GER 001.3	
	TIN 001 (A)	
3653	TIN 001 (A, 23, s)	

Fabric: Gritty orange-brown, or grey-brown, with dark grey core; cream outer surface; inclusions: a discrete fabric with abundant well-rounded quartz, main fraction 0.2-0.5 mm, occasional max. of 3.5 mm; a scatter of very fine lime < 0.1 mm and some rounded grains 0.2-0.3 mm.

Type 229. Flagon

CMD No	Context	Other Information
3694	TIN 001 (B)	Buff fabric

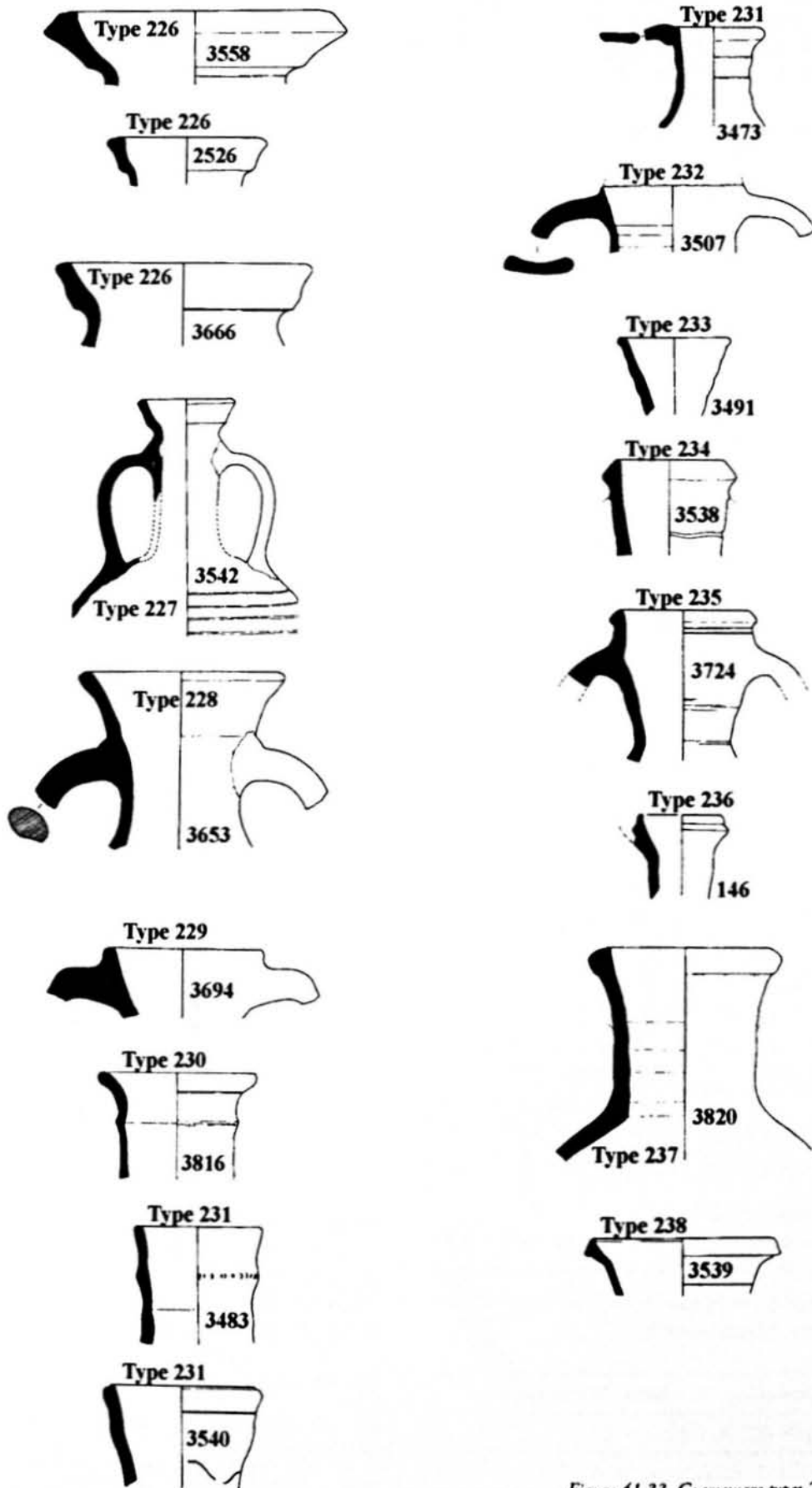

Figure 41.33. Coarseware types 226-238. 1:4.

Type 230. Jug

This form is designated LR Jug 1 at Carthage (Tomber 1988, 472 and fig. 7, nos 163-4; Fulford 1984, Closed Form 10). Mid 4th-mid 6th century AD.

CMD No	Context	Other Information
3816	LEK 009	Sandy, dull red fabric, yellowish slip
4198	TWE 011	Sandy buff fabric, slightly lighter ext. surface

Fabric: The fabric of vessel [4198] conforms reasonably well to the 'Plain Ware' of the Carthage examples (Tomber 1988, 469), that of 3816 less so.

Type 231. Jug

Late?

CMD No	Context	Other Information
3473	ZOU 001	Brick red fabric inside, dark surface
3483	ZOU 002	Hard brown fabric inside, darker natural grey outside
3540	ZOU 002 (G)	

Type 232. Jug

As we have not examined the vessel, we cannot tell whether it was actually double-handled or simply conventionally represented that way. If it was single handled then it is similar to LR Jug 3 at Carthage (Tomber 1988, 42 and fig. 7, nos. 170-2). Date: mid 4th – mid 6th century AD.

CMD No	Context	Other Information
3507	ZOU 004	Dark brown grey fabric; darkish on surfaces

Type 233. Jug

This form is designated LR Jug 3 at Carthage (Tomber 1988, 472 and fig. 7, nos 170-2). Date: mid 4th-mid 6th century AD. The fabric of our example may be one of the 'cooking ware' fabrics in which the Carthage type sometimes occurs (Tomber 1988, 470).

CMD No	Context	Other Information
3491	ZOU 006	Dark fabric with white grits. Dark surface and light yellowish slip

Type 234. Flagon

CMD No	Context	Other Information
3538	ZOU 002 (G)	

Fabric: Sandy, slightly orangey-brown, greyish brown surfaces; inclusions: abundant rounded quartz, main fraction 0.1-0.2mm, occasional max of 0.8mm.

Type 235. Flagon

CMD No	Context	Other Information
3725	RUG 001	

Fabric: Well-fired, sandy dark grey; inclusions: abundant rounded quartz, main fraction ≤ 0.1 mm, some 0.1-0.2mm, occasional max of 0.5mm.

Type 236. Flagon

CMD No	Context	Other Information
146	TAG 001	Hard self-coloured fabric, almost a fine ware
3611	TIN 001 (BE)	

Type 237. Flagon

CMD No	Context	Other Information
3820	LEK 009 (G)	

Fabric: Sandy-gritty red-brown, smoothed black surfaces; inclusions: moderate rounded quartz, main fraction ≤ 0.1 mm, some 0.1-0.2mm, a little 0.2-0.5mm; sparse rounded lime, main fraction ≤ 0.2 mm, occasional max of 0.5mm.

Type 238. Flagon

CMD No	Context	Other Information
3539	ZOU 004	Buff fabric

Type 239. Flagon or Jug

CMD No	Context	Other Information
	GER 011 (T A2.4)	Dark purplish, hard
429	ZIN 011 (30)	Reddish brown

Type 240. Flagon or Jug

Similar vessels have been found in tombs of mid-Roman date at Raqqada (Salomonson 1968). Suggested date: 3rd-4th century AD.

CMD No	Context	Other Information
	GER 011 (T A2.3)	Fine red polished

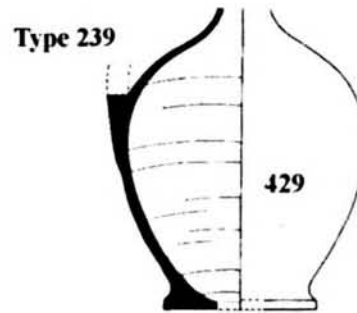
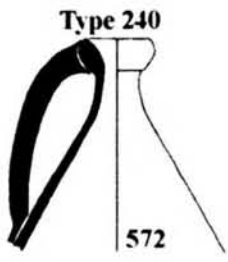

Figure 41.34. Coarseware types 239-241. 1:4.

CMD No	Context	Other Information
	GER 011 (TA2.2)	Fine, red, polished
	GER 011 (TA2.2)	Fine, red, polished
572	ZIN 026 (N)	Hard grey; white calcite, grit flecks
279	ZIN 280 (S)	Red, hard metallic, slightly darker strip on handle (ARS?)

Type 241. Flagon

CMD No	Context	Other Information
	GER 011 (TA2.3)	Brown sandy fabric, darker surface

Type 242. Flagon2nd century AD?

CMD No	Context	Other Information
[H202]	Jarma area = perhaps GER 011?	Pink, sandy fabric, cream slip
[H46]	GER 011 (TA2.3)	
[H45]	GER 011 (TA2.3)	
[H5]	GER 011 (TA2.1)	

CMD No	Context	Other Information
3000	FJJ 002	Red fabric
4047	Jarma area	

Type 243. Flagon

CMD No	Context	Other Information
[H101]	GER 011 (TA2.2)	
[H20]	GER 011 (TA2.4)	Refined red clay. Combed wavy lines surrounded the body, inside incised horizontal lines
[H97]	GER 011 (TA2.4)	Pale buff
3756	RUG area	Fabric orange brown outer, dark brown inner, cream brown outer surface, inclusions abundant quartz, less lime

Type 244. Flagon or Bowl?

Islamic. It is difficult to decide whether this fragment is from the body of a flagon or a bowl.

CMD No	Context	Other Information
3826	LEK 009	Sandy fabric grey surface; glazed outside

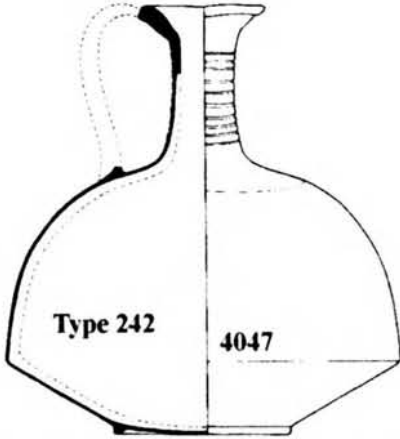
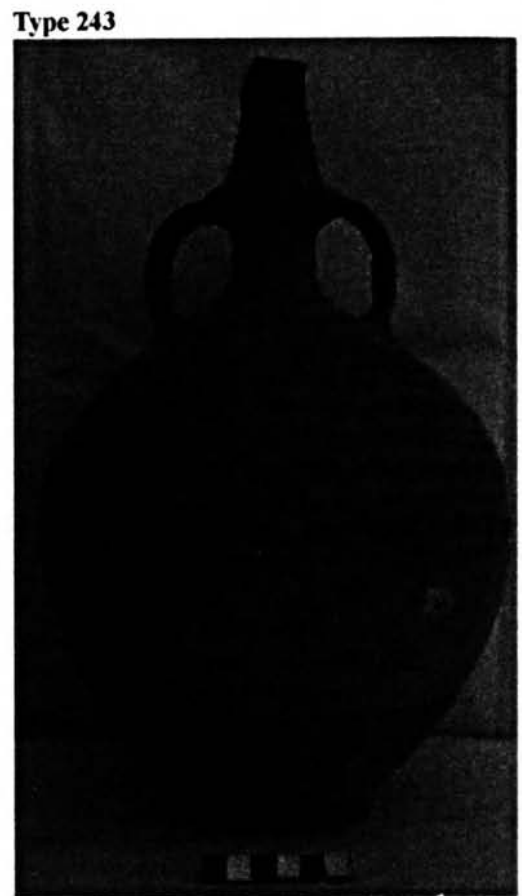
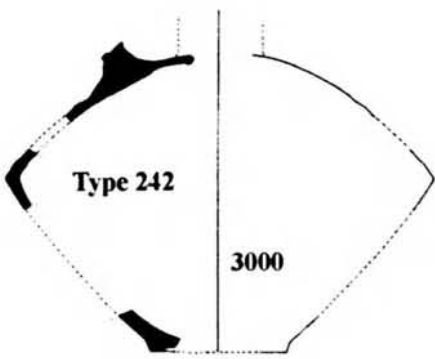

Type 242 H45



Type 243 H20



Type 243

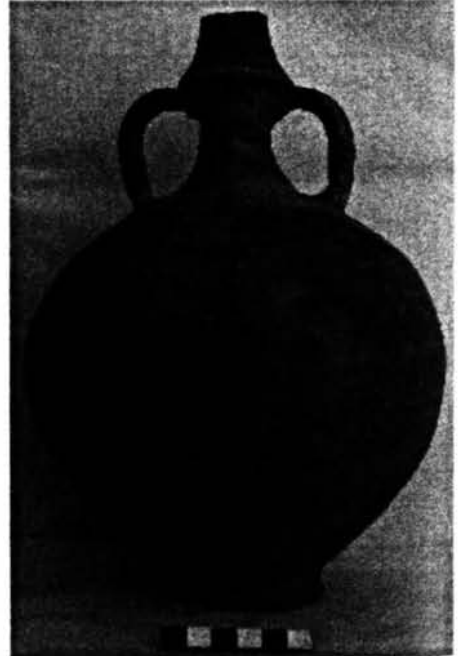

Type 242



H46

H97

H101

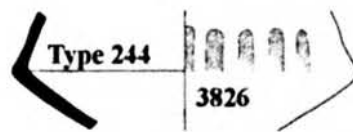

Figure 41.35. Coarseware types 242-244. 1/4.

PART E. HANDMADE VESSELS

Type 301. Jar or Bowl

A deep wide-mouth jar or bowl. The evidence of [1311] suggests a hemispherical and footless body-shape. At any rate no footed base fragments have been found which could be associated with this type. The upper wall is slightly in-turned and there is a pronounced lip on the back-face of the rim. The outer face of the rim carries a plain moulding above a deep horizontal groove. In many examples there are small holes pierced (before firing) in this groove through the vessel wall to the interior. The only part of the type which is usually decorated is the flat area on the top of the rim. For the most part this decoration consists of simple impression but in a few examples (1231 and 3650) the decoration appears to have been made by a rocker stamp.

CMD No	Context	Other information
1231	ZIN 013 (110)	Zinkekrā fabric/ ø 22 cm
58	ZIN 013 (1)	Zinkekrā fabric/ ø 31.6cm
47 [1311]	ZIN 001-003	
1133	ZIN 013 (32)	Zinkekrā fabric/ ø 26 cm
1251	ZIN 013 (110)	Zinkekrā fabric/ ø 21.2 cm
260	ZIN 037(1)	Zinkekrā fabric; RTHM3/ ø 28 cm
	ELH 005	
	ELH 005	
3650	TIN 001 (A)	

Type 302. Jar or Bowl

A similar form to Type 301 but shallower and more open. The upper wall is generally slightly out-turned, or approximately vertical, but sometimes leans inwards very slightly. There is usually a slight lip to the inner face of the rim and a very slight flange to the outer, above a deep horizontal groove which, like that in type 301, is pierced at regular intervals. As in type 301, the only area decorated is the rim top, simple impression being the general rule.

CMD No	Context	Other information
3805	CHA 007	Berber red fabric
95	ELH 006	Berber red
1480	ELH 003	Berber red
1470	FJJ 002	Red fabric with white grits and some quartz

CMD No	Context	Other information
1453	GER 002	Berber red
1235	GER 002 (4)	Berber red with white flakes
104	GER 002 (G)	Grey fabric
	GER 016	
	GER 016	No drawing
1228	ZIN 013 (108)	Zinkekrā fabric/ ø 18 cm
53	ZIN 011 (10)	Zinkekrā fabric/ ø 30 cm
1101	ZIN 013 (107)	Zinkekrā fabric/ ø 10.8 cm
1242	ZIN 013 (36)	Zinkekrā fabric; RTHM1; RTHM16/ ø 25.6 cm
441	ZIN 001-003	Dark grey fabric
1367	ZIN 001	Berber red
426	ZIN 007	Berber red
	ZIN 904	
	ZIN 904	No drawing

Type 303. Bowl

The upper wall is mostly upright but slightly in-turned in some examples. The upper wall is of an even thickness and the rim is plain and without the external moulding and internal lip of types 301 and 302. Where it resembles these types more closely is in having the deep horizontal groove on the external surface just below the rim, pierced at regular intervals. [116] is decorated on its exterior surface with a simple impressed pattern (confirmed by re-examination of the vessel, in 2000). Several examples have decoration on the rim top. That of [1172] appears to be a wavy line scribed in the clay before firing.

CMD No	Context	Other information
3776	CHA 005	Sandy light red fabric
	ELH 006	No drawing, incl. with 57
1122	GBD 001	
57	GER 002 (.2)	Light fabric, with white flakes; RTHM1
499	ZIN 001-003	
1468	ZIN 001-003	
1237	ZIN 011 (17)	Brickish fabric
1172	ZIN 011 (24)	Dark grey fabric
116	ZIN 0 13 (U/S)	Zinkekrā fabric/ ø 10.8 cm. Decorated

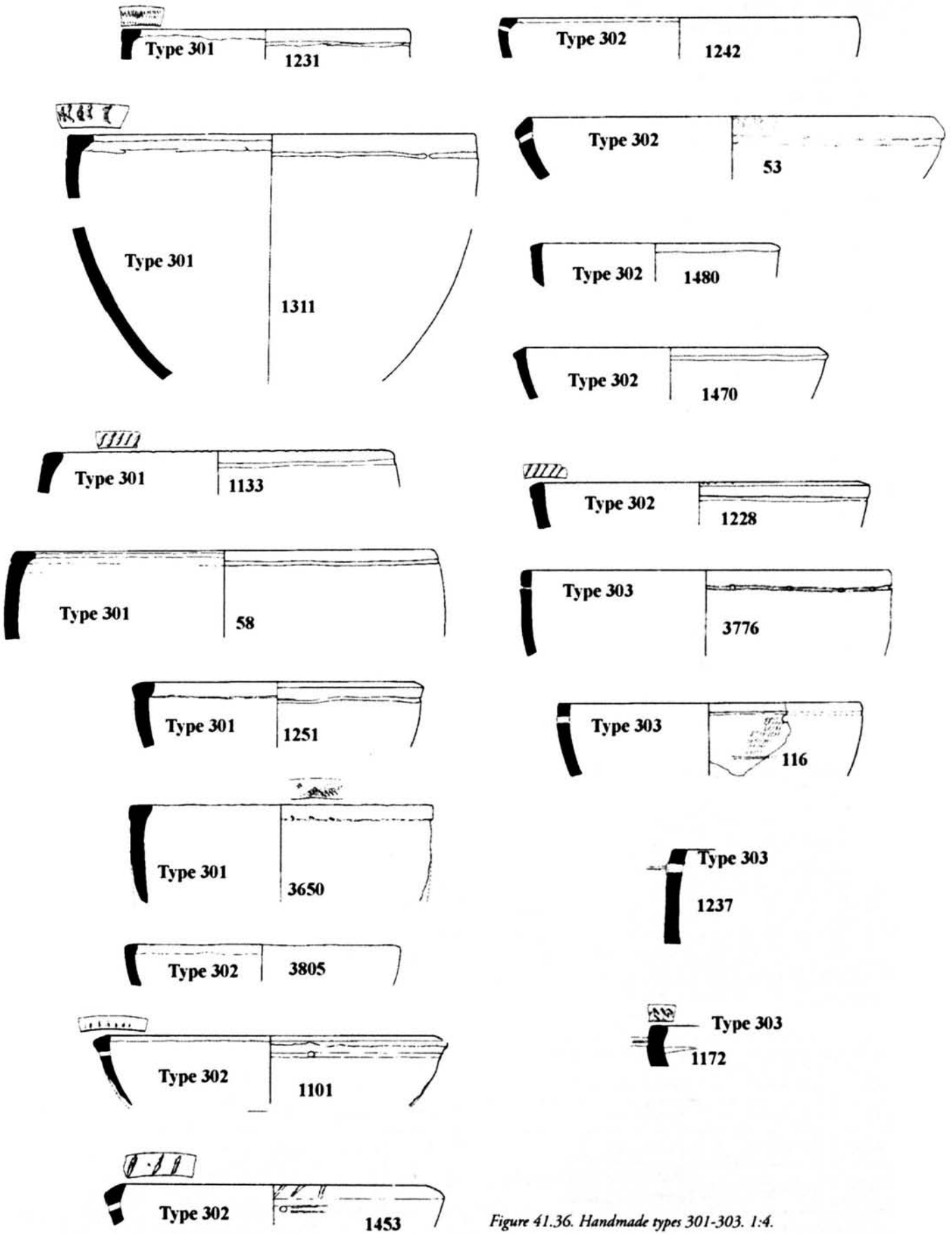

Figure 41.36. Handmade types 301-303. 1:4.

Type 304. Jar or Bowl

A deep bowl of similar form to type 301. It has a thickened, in-turned upper wall but it does not have the pronounced internal lip to the rim as in type 301. As with types 301, 302 and 303, it has the deep horizontal groove just below the rim, pierced at intervals. One example, [3783] is decorated on the exterior surface though the exact character of this decoration is unclear from the drawing (though it could quite well be rocker).

CMD No	Context	Other information
3787	CHA 005	
3649	TIN 001	Black fabric
1494 [DZ 338]	ZIN 060	Zinkekrā fabric
4 [DZ 18]	ZIN 013	Zinkekrā fabric
55	ZIN 001-003	
1243	ZIN 013 (109)	Dark grey fabric with white flakes
1490	ZIN 060 (S0)	Zinkekrā fabric/ø 23.2cm

Type 305. Deep Jar

The basic form is that of a deep jar with a markedly in-turned upper wall and a more or less developed rim. In the one example which shows an almost complete profile [Daniels 1968, no 56], the body is approximately globular. The upper wall terminates in a rim which is thickened and, in most cases, lightly moulded on its exterior surface. [1564] which is highly abraded may be an example of this type.

Variation in form is discernible – mostly in the degree to which the moulding articulating the rim is developed – but the sample is not nearly large enough to say whether the variation is significant or whether there is a chronological component to it. Vessels recovered by the Fazzān Project from inter-dune sites in the Ubārī sand sea (code EDU; see Part F below) in association with Holocene lithics are of the same type.

Half of the examples of this type carry some form of decoration on the flat band formed by the upper surface of the in-turned rim. Of these, the majority carry bands of packed zig-zag rocker while a few are decorated with simple rocker technique. There are a few examples (59, 1356 and 3416) which carry decoration which appears to have been made with an alternately pivoting stamp, and one example (223) carrying simple impression. Examples from the Ubārī sand sea (EDU 26, 136, 217, 472) also clearly carry decoration on the area below the rim and in common with many examples of high quality ceramics which seem to have been common in the middle Pastoral, may well have been extensively decorated on

their exterior surfaces. Table 41.14 below summarises the information.

Table 41.14. Type and location of decoration on selected handmade vessels.

CMD No	Rim	Wall
1289	packed rocker	
223	simple impression	
199	alternate pivot	
56	undecorated	
472		present
67	simple rocker	
1462	packed rocker	
1469	simple rocker	
3659	present	
3661		
136		present
217		present
1211	present	
26	packed rocker	
EDU 026	packed rocker	packed rocker
225		
99		
1089		
1185		
1288		
1356	alternate pivot	
3416	alternate pivot	
EDU 026 Part F, Cat 14		
EDU 026 Part F, Cat 17		? packed rocker

Taking into account the evidence of the examples recovered from the Ubārī sand sea, it seems likely that this is a long-lived type, starting conceivably as early as the middle Pastoral, and continuing down into the Garamantian period in the middle of the 1st millennium BC. One might suggest that the earlier examples of the type are more likely to carry extensive packed rocker decoration on their exterior surfaces while later examples are more likely to carry only decoration on their rims or to be completely plain.

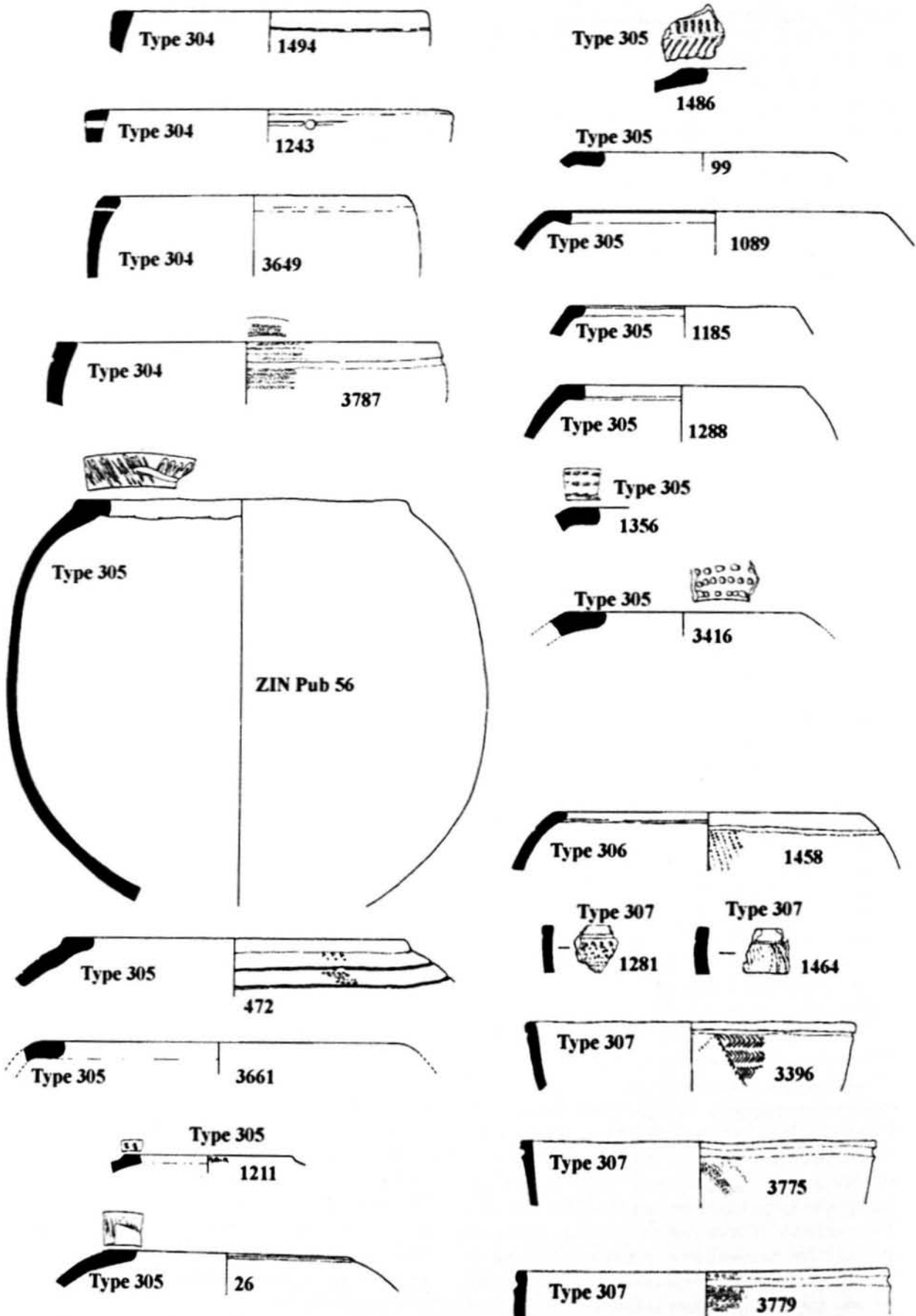

Figure 41.37. Handmade types 304-307. 1:4.

CMD No	Context	Other information
1288		
3416	CLF 008 (53, 3)	
1469	GER 002 (5)	Berber red
	GER 033	
2762	LAR 001	
3659	TIN 001 (A)	
3661	TIN 001 (A)	
472	TIN 001 (G)	
472	TWE 004?	Dark fabric
223	ZIN 001-003	Zinkekrä fabric/ ø 30.4 cm
	ZIN 001-003	Black berber fabric
1486	ZIN 001-003	
99	ZIN 011 (20)	
1089	ZIN 013 (105)	
1185	ZIN 013 (35)	
1356	ZIN 013 (42)	
1564	ZIN 101 (E)	Zinkekrä fabric/ ø 14cm
67 [DZ 205]	ZIN 011 (26)	Dark black fabric
1211	ZIN 013 (108)	Zinkekrä fabric/ ø 24.8 cm
26 [DZ 79]	ZIN 013 (4)	Berber red
1462 [DZ 340]	ZIN 060 (5)	Dark grey fabric
1289	ZIN 070(1)	Zinkekrä fabric; RTHM3/ ø 25.2 cm
225	ZIN 001 (S)	Zinkekrä fabric/ ø 15.8 cm
217	ZIN 001 (S)	Zinkekrä fabric/ ø 24.8 cm
1062	ZIN 001 (S)	Dark grey fabric
136 [DZ 292]	ZIN 047 (S)	Berber red
59	ZOU 006	Berber red

Type 306. Deep Jar

A deep jar with a markedly inturned upper wall and plain, inturned rim. There is a deep horizontal groove on the exterior surface just below the rim. The external surface is decorated, though the precise character of this cannot

be gauged from the drawing. The form has elements in common with type 301, most notably the rim and the horizontal groove, but the upper wall is much more markedly inturned than in that type, and it shares this characteristic much more with type 305. One might possibly regard it as in some sense a transitional form linking the two types.

CMD No	Context	Other information
1458	ZIN 051(1)	Zinkekrä ware/ø 21.2 cm
1490	ZIN 060 (S0)	Zinkekrä fabric/ ø 23.2cm

Types 307 – 310. Bowls/Dishes

These types form a related series of relatively shallow bowls or dishes all with a single horizontal groove on the exterior surface just below the rim. They are distinguished one from another by the form of the rim: all except type 310 are unthickened or only slightly thickened; type 307 has a flat top while type 308 has a more rounded profile; type 309 (which may represent a single anomaly rather than a definable type) has a somewhat reduced rim; type 310 has a thickened rim with a flat top.

For type 307 the drawings are clear enough to suggest that two examples (1281 and 1464) carried zig-zag rocker stamp decoration. For type 308, the drawings clearly show alternately pivoting stamp impressions. The one example of type 309 may bear packed rocker impressions. No. [1047] has packed rocker stamped impression on the rim top.

A vessel similar to type 310 was recovered by the Fazzân Project from inter-dune sites in the Ubâri sand sea (EDU; see Part F below) suggesting that the type has formal antecedents in the middle or late Pastoral periods.

Type 307. Bowl or Dish

CMD No	Context	Other information
3775	CHA 005	Black berber fabric, with grits
3779	CHA 005	Black berber fabric
3396	CLF 004	Black berber fabric with grits
1464	ELH 004	Berber red. Decorated
31	GER 002 (G)	Grey granular fabric with quartz
1281	GER 002 (3, 2)	

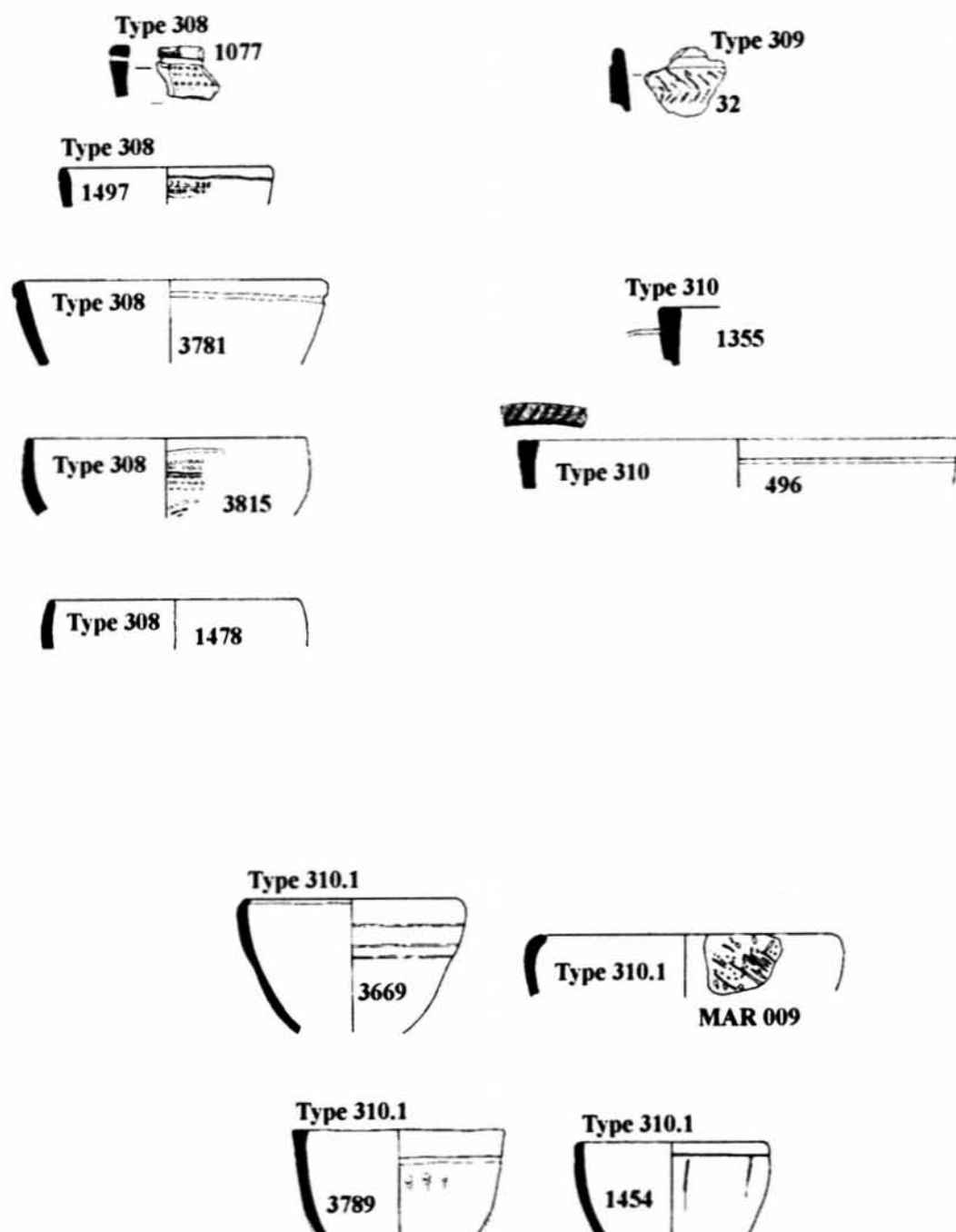

Figure 41.38. Handmade types 308-310.1. 1:4.

Type 308. Bowl or Dish

CMD No	Context	Other information
3781	CHA 005	Black fabric, red surface
1497	ELH 003	Berber red. Decorated
3815	RUG 006	Black berber fabric
439	ZIN 001-003	Berber red
1478 [DZ 331]	ZIN 060	Black fabric

CMD No	Context	Other information
1077	ZIN 011	No fabric description. Decorated
1439	ZIN 001 (S)	Grey fabric. Decorated

Type 309. Bowl or Dish

CMD No	Context	Other information
32	TAG 001	Berber red. Decorated

Type 310. Bowl or Dish

CMD No	Context	Other information
	EDU 018	
496	GER 001 (19)	Black fabric. Decorated
1428	ZIN 001-003	Berber red
1355	ZIN 013 (1)	Grey fabric
1047	ZIN 001 (S)	Berber red

Type 310.1. Small Bowl/Cup

Small bowl or cup with a plain, inturned rim. The vessels are thin-walled and well-made. The fabric is a fine black with a burnished red-brown surface. Although the external surface of the example from MAR 009 is abraded, traces of packed rocker stamp decoration can be clearly discerned.

CMD No	Context	Other information
3784	CHA 001	Black fabric
	MAR 009	
3669	TIN 001 (A)	
1454 [DZ 355]	ZIN 075	Black fabric

Type 311. Jar

Necked jar. Most of the examples of this type survive as rim sherds with only small amounts of the body attached. The one exception to this is [3707] from TIN 001 where an associated, but non-conjoined, body sherd suggests that the body shape of the type was globular or ovoid. The type is characterised by a neck, for the most part quite short and a plain rim. The distinguishing characteristic of the rim is its flat top and more or less square sectional profile. There is some variation in rim shape within the type which can be characterised as follows: a) short, very upright, neck articulated both in the interior and exterior profile; b) short, upright, neck articulated only in the exterior profile; c) as (b), but somewhat taller.

The type is very often decorated on the rim top, mostly, as far as can be judged from the drawings, with simple impression.

Eighty percent of the examples of this type are from Zinkekrā. Two are from Tinda (TIN 001), and one from CLF 002.

CMD No	Context	Other information
4031	CLF 002	Berber red
3707	TIN 001	Black fabric
3635	TIN 001 (A)	

CMD No	Context	Other information
485 [DZ 209]	ZIN 119	Berber red
440 [DZ 275]	ZIN 034 (3)	Dark grey fabric
113 [DZ 200]	ZIN 011 (17)	Brickish fabric
96 [DZ 180]	ZIN 011 (20)	Dark, grey fabric
1194	ZIN 013 (1)	Dark grey fabric
1081	ZIN 013 (111)	Grey fabric
1144	ZIN 013 (32)	Black grey fabric
1191 [DZ 104]	ZIN 013 (107)	Zinkekrā fabric/ ø14.8cm. Phase Z3
1246	ZIN 013 (109)	Black-grey fabric; RTHM3
	ELH 006	
1178 [DZ 133]	ZIN 013 (110)	Berber red
1245 [DZ 146]	ZIN 013 (111)	Brown fabric, black surface
1422	ZIN 013 (111)	Zinkekrā fabric/ ø14.8 cm. Phase Z0

Type 312. Deep Jar

A deep jar with a markedly inturned upper wall and rim surmounted by a lid-locating collar. The exterior surface below the rim is decorated (with simple impression to judge from the drawing), as are the rim top and the top of the collar.

CMD No	Context	Other information
1058	GSC 008	Black fabric

Type 313. Jar

Small jars with bead rims

CMD No	Context	Other information
1351 [DZ 65]	ZIN 013 (56)	Zinkekrā fabric/ ø 9.2 cm
1227	ZIN 017(38)	Zinkekrā fabric/ ø 13.2 cm

Type 314. Jar or Bowl

Necked wide-mouth bowl or jar. A complete profile is known for the one example of this type. The base is round and unfooted; The plain, everted rim is articulated from the body by a slight shoulder. The external surface is almost completely covered with zig-zag rocker decoration.

CMD No	Context	Other information
1411 [DZ 52]	ZIN 013 (39)	Zinkekrā fabric/ ø 15.2 cm. Phase Z2

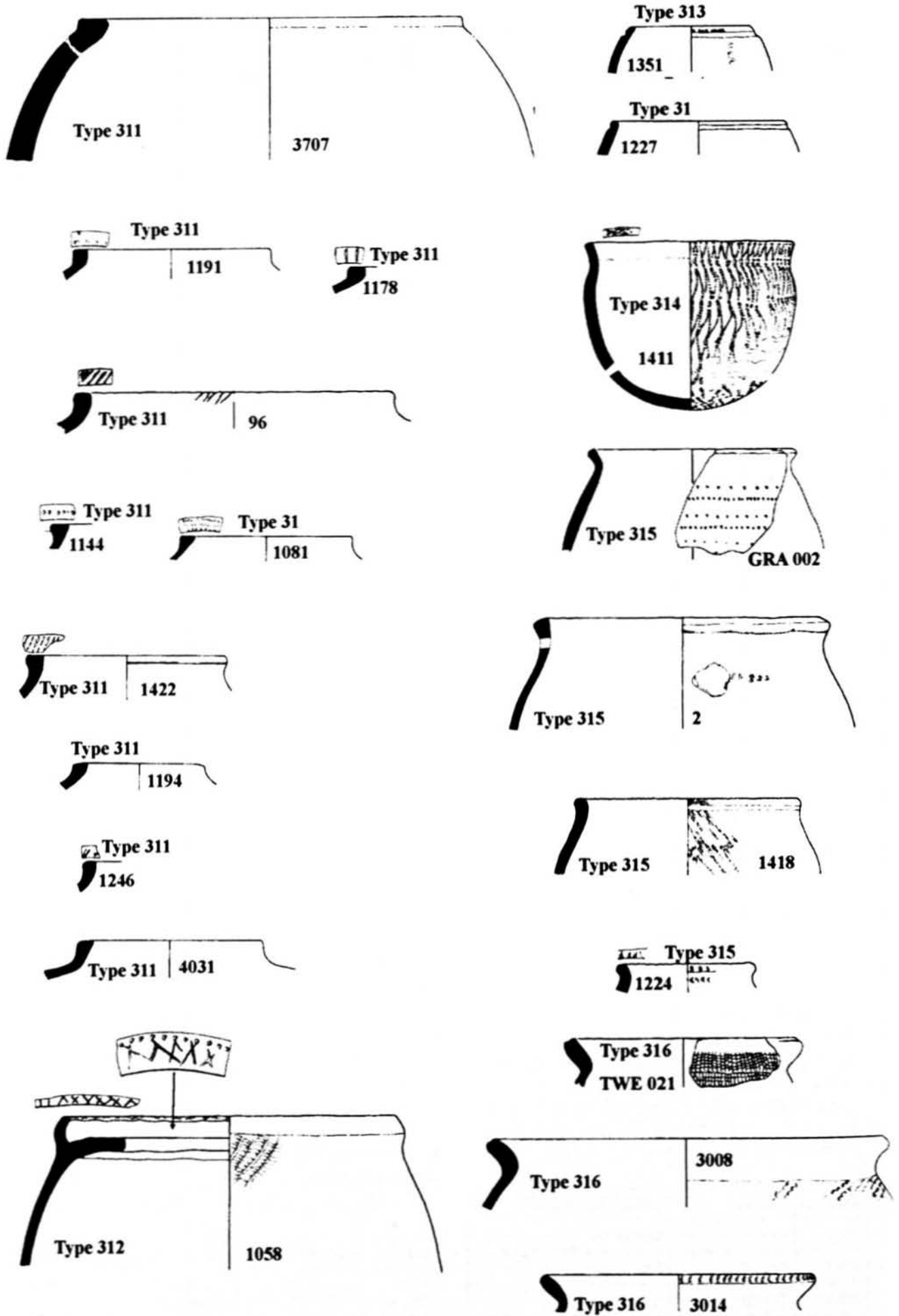

Figure 41.39. Handmade types 311-316. 1:4.

Type 315. Jar

The plain, everted rim is slightly thickened. There is no shoulder. The fabric, particularly of the example from GRA 002, is thick with a somewhat lumpy and poorly finished surface. The external surfaces of two examples of the type are decorated with alternately pivoting stamp impressions.

CMD No	Context	Other information
	GRA 002	Rim sherd and five wall sherds probably all from the same vessel. Diameter at rim: 160mm. Average wall thickness: 9.5mm. Sandy black with dark brown surface. Inclusions: common rounded quartz mostly ≤ 0.0 mm, occasionally up to 1.0mm. External surfaces decorated with alternately pivoting stamp impressions (non-return).
487 [DZ 212]	ZIN 119	Black fabric
1369 [DZ 161]	ZIN 011 (surface)	No fabric description
2	ZIN 013 (14)	Black berber fabric
1418	ZIN 013 (115)	Zinkekrå fabric/ $\varnothing 16.4$ cm/ Phase Z0
1319	ZIN 013 (29)	Zinkekrå fabric/ $\varnothing 15.6$ cm/ Phase Z1
1224	ZIN 013 (50)	Zinkekrå fabric; RTHM7/ $\varnothing 10$ cm Phase Z1
	ELH 006	

Type 316. Jar

The rim is more everted than in the immediately previous type. The lip of the rim carries a groove in two examples of the type. The external surfaces of two examples are decorated with packed zig-zag rocker impression.

CMD No	Context	Other information
3008	FJJ 006	Berber red
3014	FJJ 006	Berber red
	TWE 021	Rim sherd of jar. Diameter at rim 180mm. Thickness of wall below rim: 5.5mm. Sandy black fabric, orange-brown outer surface, black inner surface. Inclusions: abundant rounded quartz mainly ≤ 0.1 mm, some up to 0.5mm. Packed zig-zag rocker impressions on external surface.

Type 317. Jar

The type is distinguished by thick walls and a rim which is only slightly everted and thickened. Zig-zag rocker impression appears on the exterior surface of one example [1097] and the rim top of two others, [108] and [294]. All the examples of the type occur on Zinkekrå except one from Tuwash.

CMD No	Context	Other information
4201	TWE 011	Berber red
1422	ZIN 001-003	
24	ZIN 001-003	
103	ZIN 001-003	
82	ZIN 101-003	
[DZ 294]	ZIN 118	
259	ZIN 001-003	
108 [DZ 5]	ZIN 013 (1)	Dark grey fabric
1097 [DZ 108]	ZIN 013 (107)	Dark/brown fabric

Type 318. Jar

Small jar with everted rim. All examples from Sāniat Jibril.

CMD No	Context	Other information
2865	GER 002 (4, 74)	Berber Red/ $\varnothing 11$ cm
2304	GER 002 (6, 2)	Berber red/ $\varnothing 22$ cm
2675	GER 002 (6, 21)	Berber red/ $\varnothing 16.5$ cm
2781	GER 002 (6, 23)	Berber red/ $\varnothing 18$ cm

Type 319. Bowl or Jar

Small bowl or jar with short everted rim. Two examples from Jarma.

CMD No	Context	Other information
2710	GER 002 (6, 21)	Berber red / $\varnothing 22$ cm
2689	GER 002 (6, 21)	Berber red/ $\varnothing 17$ cm

Type 320. Jar

Large jars with tall, upright rims. At least one of these, [1254], is decorated with packed zig-zag rocker.

CMD No	Context	Other information
3418	CLF 002	Berber red
3442	CLF 002	Black fabric
2886	GER 002 (4, 110)	Berber red/ $\varnothing 23$ cm
3641	TIN (A, 12, 4)	Berber red

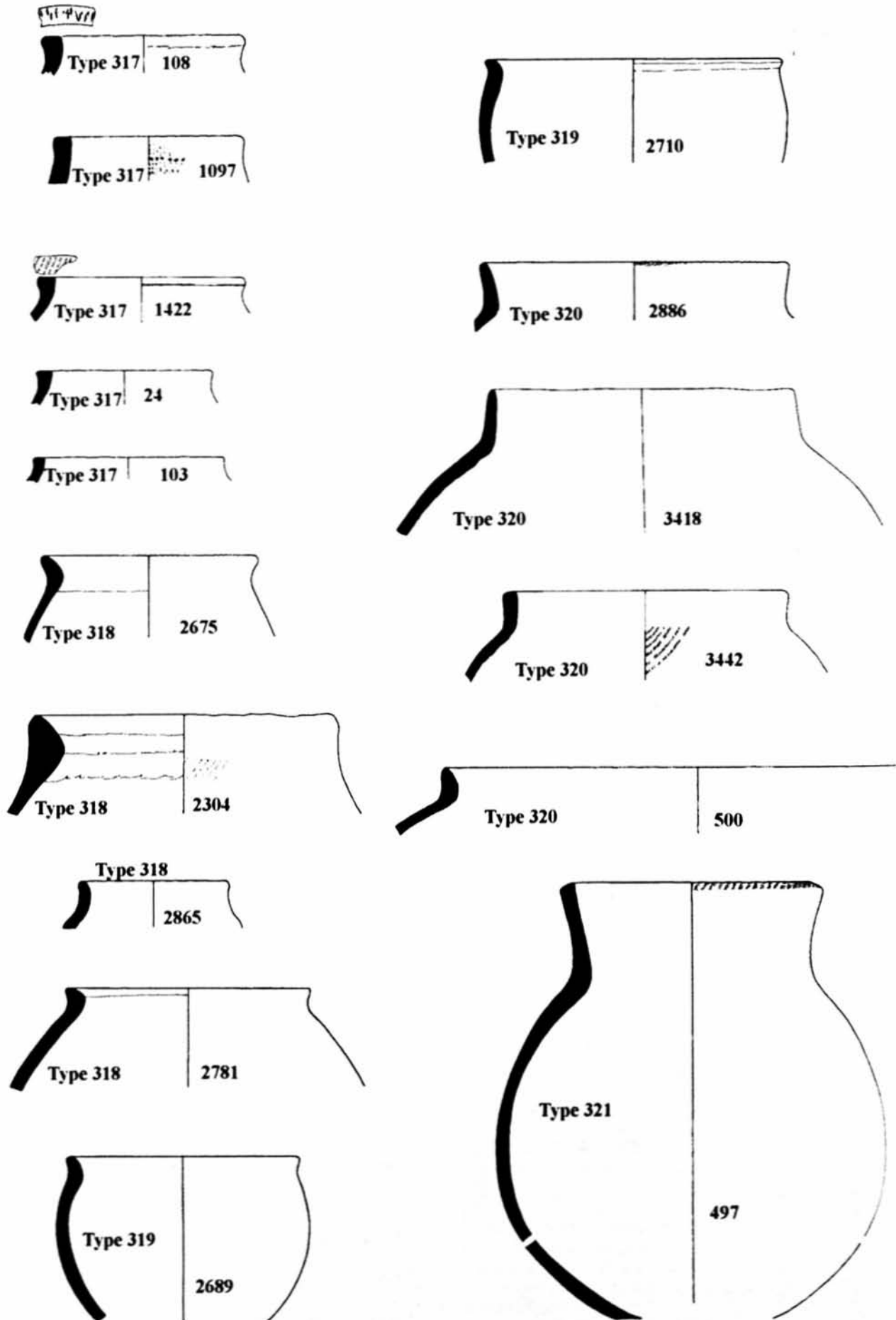

Figure 41.40. Handmade types 317-321. 1-4.

CMD No	Context	Other information
500 [DZ 395]	ZIN 109 (5)	Berber red
1254 [DZ 249]	ZIN 218 (3)	Black fabric

Type 321. Deep Jar

The Zinkekrā example shows an almost complete profile, which is round-bottomed and unfooted. The rim is tall and slight everted. There is decoration on the rim top though its precise character cannot be judged from the drawing. Occurrences at Zinkekrā, CHA 001 and GER 002, 016 suggest a date range of late 1st millennium BC – c. 4th century AD.

CMD No	Context	Other information
	CHA 001(2)	
	GER 002	
	GER 016	
497 [DZ 391]	ZIN 101 (2)	Berber fabric

Type 322. Jar

The rim is slightly out-turned, the lip is square in sectional profile, often decorated and with a single horizontal groove inside it. Many examples are decorated on their exterior surfaces: [1197] bears alternately pivoting stamp decoration, and [1186] packed rocker. All the examples are from Zinkekrā. The type shows the deep horizontal groove on the external surface pierced at intervals, a characteristic typical of types 301, 302 and 303. Like these types, type 322 can be thought of as typical of Zinkekrā.

CMD No	Context	Other information
1239 [DZ 250]	ZIN 218 (2)	Dark grey fabric
431 [DZ 276]	ZIN 034 (4)	No fabric description
27 [DZ 192]	ZIN 011 (8)	Grey fabric
1105	ZIN 013 (103)	Dark red metallic fabric
1210 [DZ 132]	ZIN 013 (11)	Dark grey fabric
1186 [DZ 106]	ZIN 013 (108)	Black grey fabric

CMD No	Context	Other information
1195 [DZ 105]	ZIN 013 (109)	Black grey fabric
1197 [DZ 144]	ZIN 013 (111)	Grey fabric

Type 323. Jar

Of similar form to that of type 322 it is distinguished from the latter in having a minimally developed flanged lip to the rim. [1066] displays what is almost certainly alternately pivoting stamp impressions. All examples are from Zinkekrā.

CMD No	Context	Other information
	CHA 026/027	
	ELH 006	
1030	ZIN 013 (39)	Zinkekrā fabric/ ø16.8 cm Phase Z2
1093	ZIN 013 (107)	Zinkekrā fabric, RTHM1/ ø14.8 cm Phase Z3
1429	ZIN 013 (50)	Zinkekrā fabric/ ø 13.6 cm/ Phase Z1
1066	ZIN 013 (48)	Zinkekrā fabric; RTHM3/ ø14.8 cm Phase Z1

Type 324. Jar

A necked jar with a flange rim; the flange is generally rounded in sectional profile. The top of the rim most usually carries packed rocker impressed decoration. Of the nine examples, seven are from Zinkekrā, the remainder being from CHA 001 and TIN 001.

CMD No	Context	Other information
1988	CHA 001	Berber red
3630	TIN 001	Berber red
1471 [DZ 324]	ZIN 060	
61 [DZ 193]	ZIN 011 (10)	Berber red
1098	ZIN 013 (32)	Dark grey fabric
10 [DZ 11]	ZIN 013 (1)	Berber red
1466 [DZ 325]	ZIN 060 (4)	Brown fabric, with white flakes
1238	ZIN 013 (108)	Zinkekrā fabric
1442	ZIN 013 (39)	Zinkekrā fabric/ ø 15.2cm/ Phase Z2

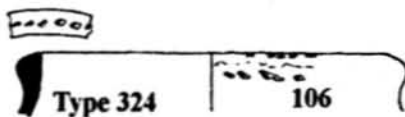
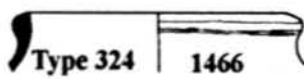
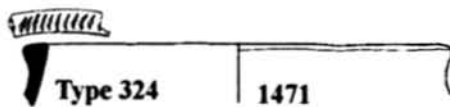
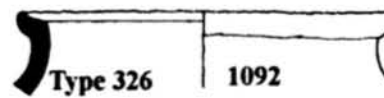
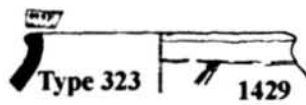
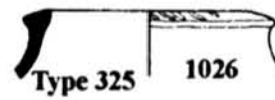
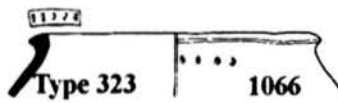
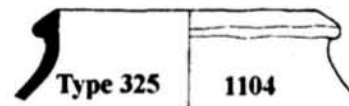
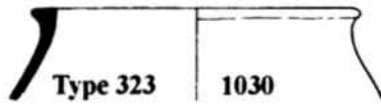
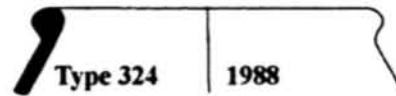
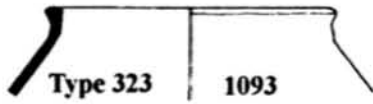
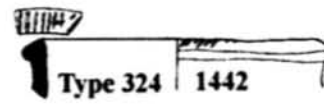
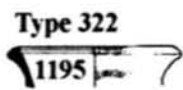
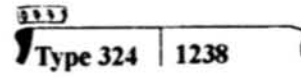
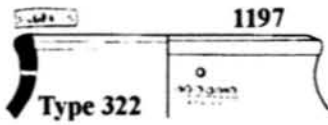
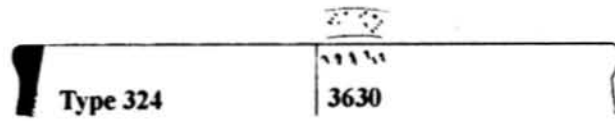
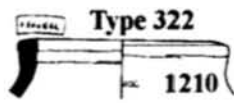
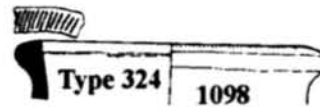
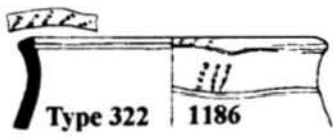

Figure 41.41. Handmade types 322-326. 1:4.

Type 325. Jar

Necked jar. Similar to 324. In contrast to 324 the rim is triangular in sectional profile and has a lid-locating groove on the inner face. All examples are from Zinkekrå.

CMD No	Context	Other information
70	ZIN 011 (20)	Zinkekrå fabric/ ø 34 cm/ Phase Z4
1026	ZIN 013 (53)	Zinkekrå fabric/ ø 12.4cm/ Phase Z1
1104	ZIN 013 (7)	Berber red

Type 326. Jar

Necked, shouldered jar with flanged rim. The flange mostly has a flat top but one example shows a concave, in-sloped face. All examples are from Zinkekrå. The complexity of the form suggests an association with Hellenistic and/or Roman wheel-made forms.

CMD No	Context	Other information
489 [DZ 211]	ZIN 119	Berber red
434 [DZ 287]	ZIN 034 (4)	No fabric description
1447 [DZ 321]	ZIN 060 (3)	Black fabric
1092 [DZ 9]	ZIN 013 (103)	Black fabric

Type 327. Small Jar

CMD No	Context	Other information
1118	ZIN 013 (106)	Zinkekrå fabric/ ø 7.6 cm/ Phase Z4
1146	ZIN 013 (109)	Zinkekrå fabric/ ø 4.8 cm Phase Z2

Type 328. Deep Bowl or Jar

CMD No	Context	Other information
1260	GSC 003	Berber red

Type 329. Deep Bowl or Jar

CMD No	Context	Other information
2646	GER 002 (4, 64)	Berber red/ ø 25 cm

Type 330. Jar

Narrow-mouth jar.

CMD No	Context	Other information
	ELH 006 (2)	
1088	ZIN 013 (107)	Zinkekrå fabric; RTHM 1, 7/ ø 8.8cm Phase Z3

Type 331. Jar

Narrow-mouth jar.

CMD No	Context	Other information
3668	TIN 001	Berber red
4195	TWE 001? (5G)	Berber red grey fabric

Type 332. Jar

Narrow-mouth jar.

CMD No	Context	Other information
3563	GBD 001	Dark grey fabric
1443	ZIN 013 (5)	Zinkekrå fabric/ ø 9.2 cm Phase Z1

Type 333. Jar

Globular jar with tall neck; painted decoration. None of the illustrated profiles indicates the form of the lower half of the body. Archive photographs suggest that it was globular and examination of fragments suggests that the manufacturing process consisted of joining together pre-fabricated globular bases and upright necks, and that this rendered the finished vessels susceptible to fracture at the joint. Vessel rims were commonly decorated with incised lines or cord or fabric impressions. The walls of the neck were commonly decorated with cross-hatching in red-brown paint on a white background. It is possible that all the vessels of this type were originally decorated in this way since the decoration, and particularly the white background is rather fugitive. It seems that this style of painting eventually evolved into that commonly seen on Medieval wares. Surviving fragments of globular bases suggest that they were routinely decorated with thick, straight, vertical lines of paint.

Many of the examples illustrated were found in Zinkekrå cemeteries, where associations with datable fine- and coarseware would suggest that they date to the 1st and 2nd centuries AD. Occurrence in stratified levels of GER 001 suggests that they were produced and used until the 4th century AD at least. It was the most widely dispersed painted form in the Roman period.

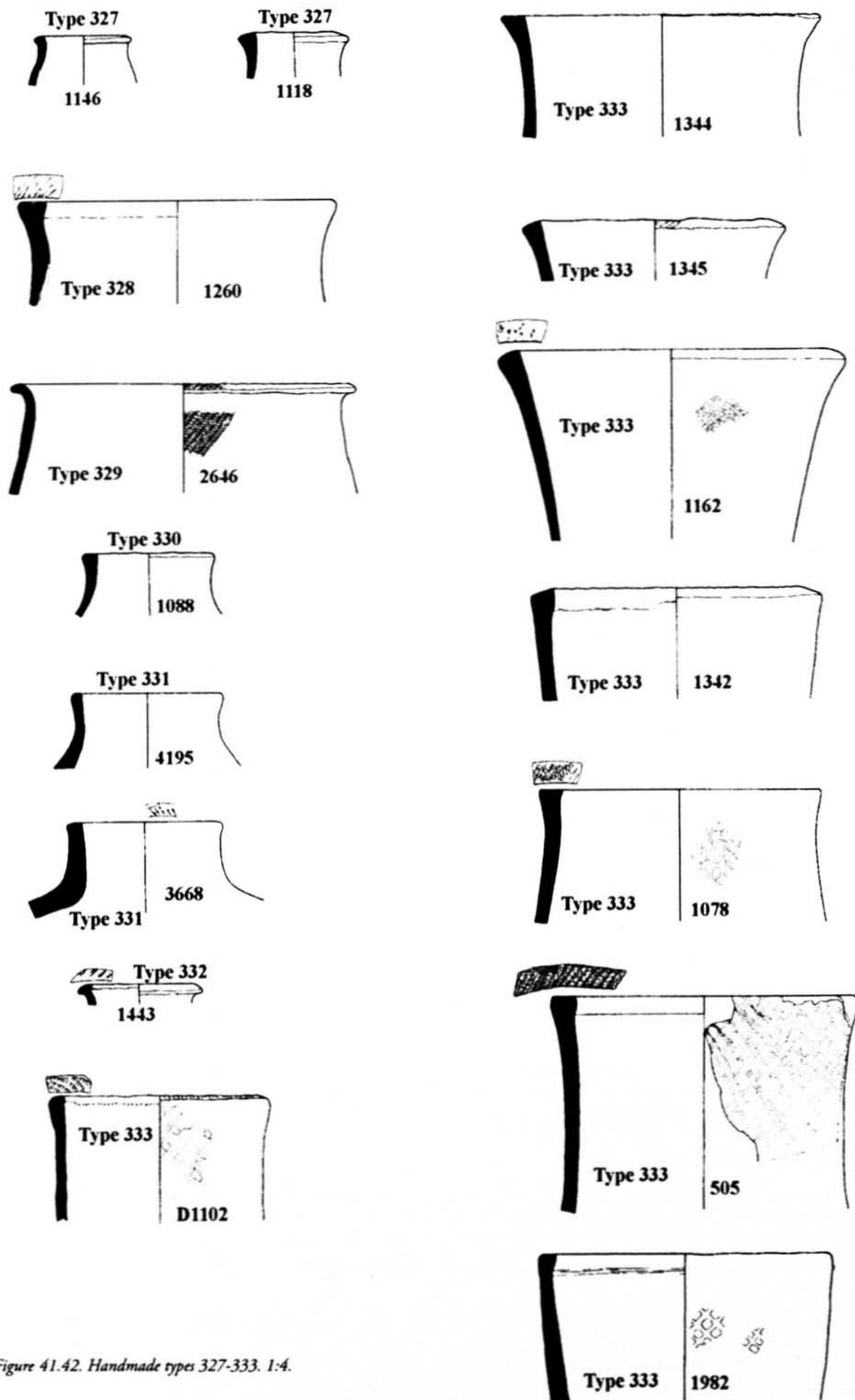

Figure 41.42. Handmade types 327-333. 1:4.

CMD No	Context	Other information
1982	CHA 001	Berber red
1344	GSC 002	Berber red
1345	GSC 002	Berber red
1342	GSC 002	Berber red
1162	GSC 007	Berber red
1078	GSC 007	Berber red
505	ZIN 109	Berber red
559	ZIN 023 (5)	Berber red/ ø 26.2cm
560	ZIN 235	Berber red/ ø 24.4cm
563	ZIN 024	Berber red fabric/ ø 26.4cm
656	ZIN 280 (G)	Berber red/ ø 14 cm
655	ZIN 280	Berber red/ ø 28cm
668	ZIN 280	Berber red/ ø 36 cm
674	ZIN 281	Berber red/ ø 23.6 cm
666	ZIN 280	Berber red/ ø 21.6 cm
1102	ZIN 330 (A)	Berber red/ ø 15.6cm

Type 334. Jar

Globular jar with tall neck; painted decoration. The neck is surmounted with a flange rim of varying length, often in-sloped. Decoration is as on the previous type suggesting that the two are of a broadly similar date. The type does not seem to occur at Zinkekrā though whether this is chronologically significant is hard to determine.

CMD No	Context	Other information
1964	CHA 001	Berber red
1995	CHA 001	Berber red
1970	CHA 001	Berber red
2030	CHA 001	Berber red
3448	CLF 008	Black fabric

Type 335. Jar

Ovoid jars with vertical lug handles and painted decoration.

As far as can be judged the form of the body is ovoid. The rim is short and generally upright or slightly inverted. In some cases it has a slightly concave inner face. At

least two lug handles are usually present situated on the shoulder of the vessel and often extending on to the neck and rim. Both the external and internal surfaces of the rim can be painted with a white ground over which are vertical red-brown lines. The external body can be similarly covered and can also bear incised inverted V-shaped motifs. The best dating evidence comes from Sāniat Jibril (GER 002) and suggests that the type emerged in the 3rd-4th centuries AD.

CMD No	Context	Other information
3422	CLF 002	Dark grey fabric
2416	GER 002 (4, 26)	Fabric hrbps/ ø 22.2 cm
2278	GER 002 (4, 26)	Fabric hrbp; RTHM3/ ø19.2 cm
	RUG 023	Cf 2278
2859	GER 002 (7,70)	Berber red/ ø 23 cm
3856	GRE 001	Black fabric with quartz
3836	GRE 001	Berber red
3847	GRE 001	Grey fabric
3857	GRE 001	Berber red
4020	LEK 007	Dark brown fabric
3741	RUG 003	Berber red black fabric
3754	RUG 003	
3528	ZOU 002	Black fabric with white inclusions
3458	ZOU 006	Black fabric
3486	ZOU 006	Berber red
3488	ZOU 006	Berber red
3520	ZOU 009	Black fabric
3718	ZOU 011	Black fabric

Type 336. Handled Cup (incense burner?)

No 3439 is more likely to date to the Medieval or post-Medieval period as the incised decoration and the position of the top joint of the handle (below the rim) are similar to modern forms. It is possible that they were used as incense burners.

CMD No	Context	Other information
3518	Jama area?	

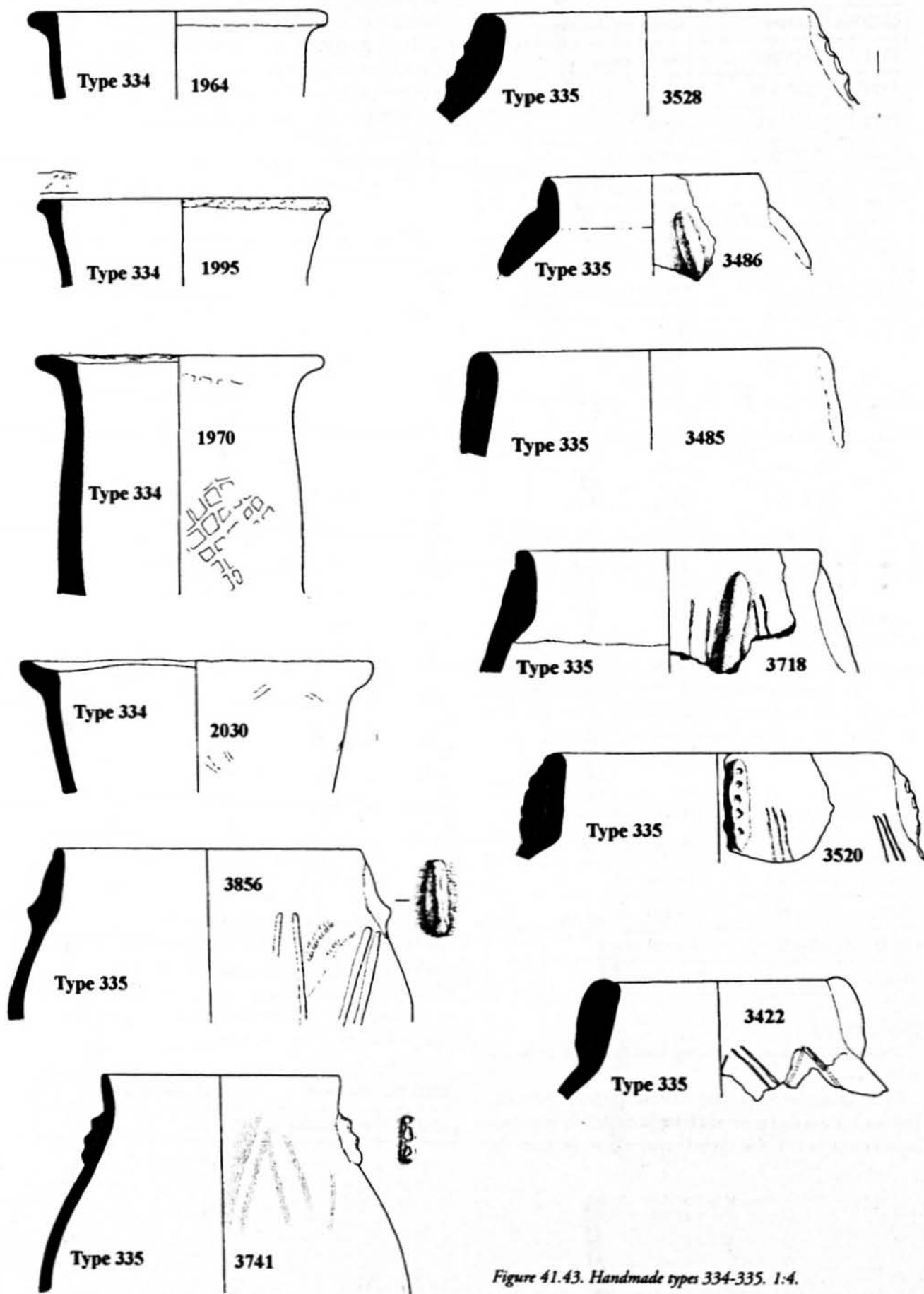

Figure 41.43. Handmade types 334-335. 1:4.

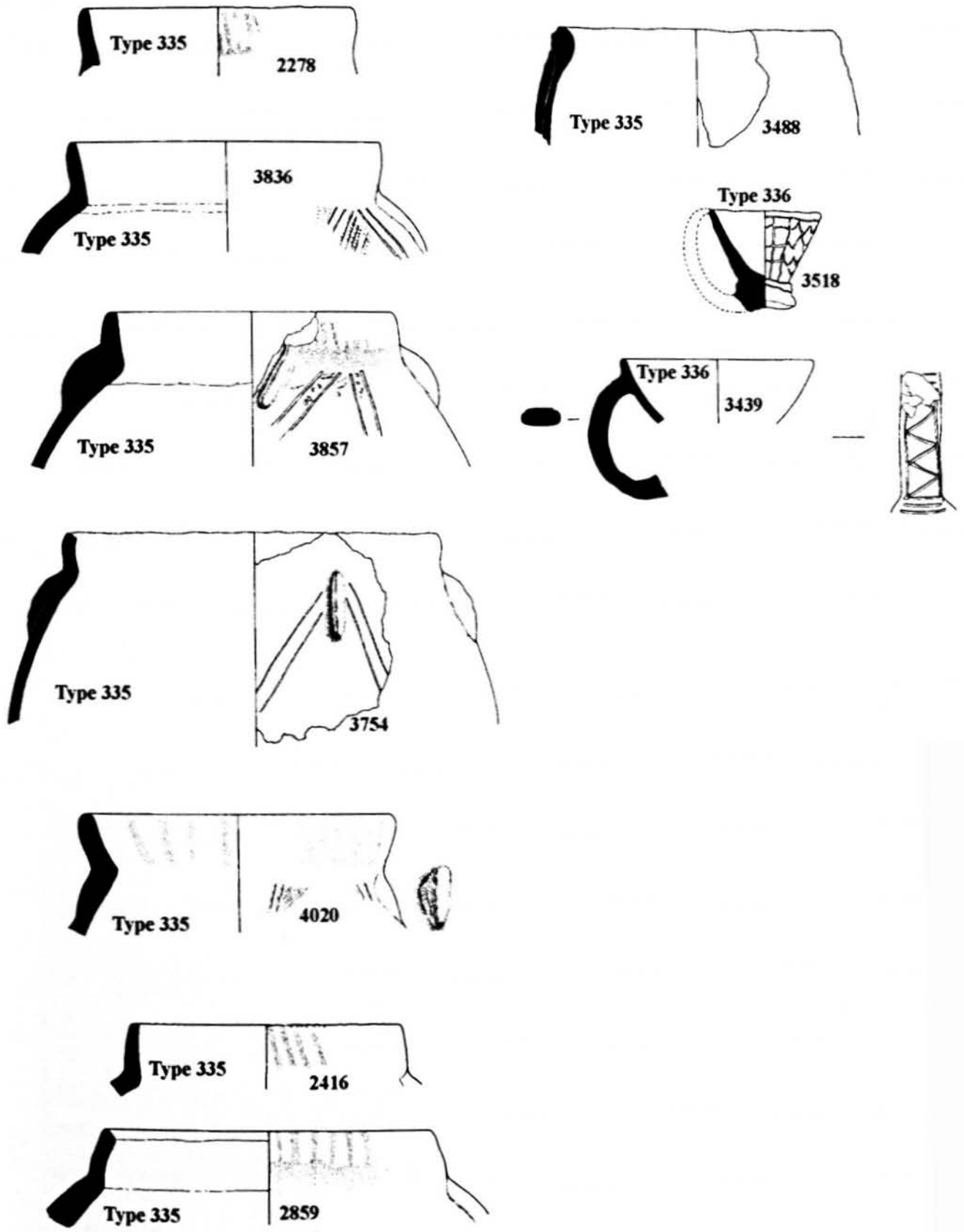

Figure 41.44. Handmade types 335 (cont)-336. 1:4.

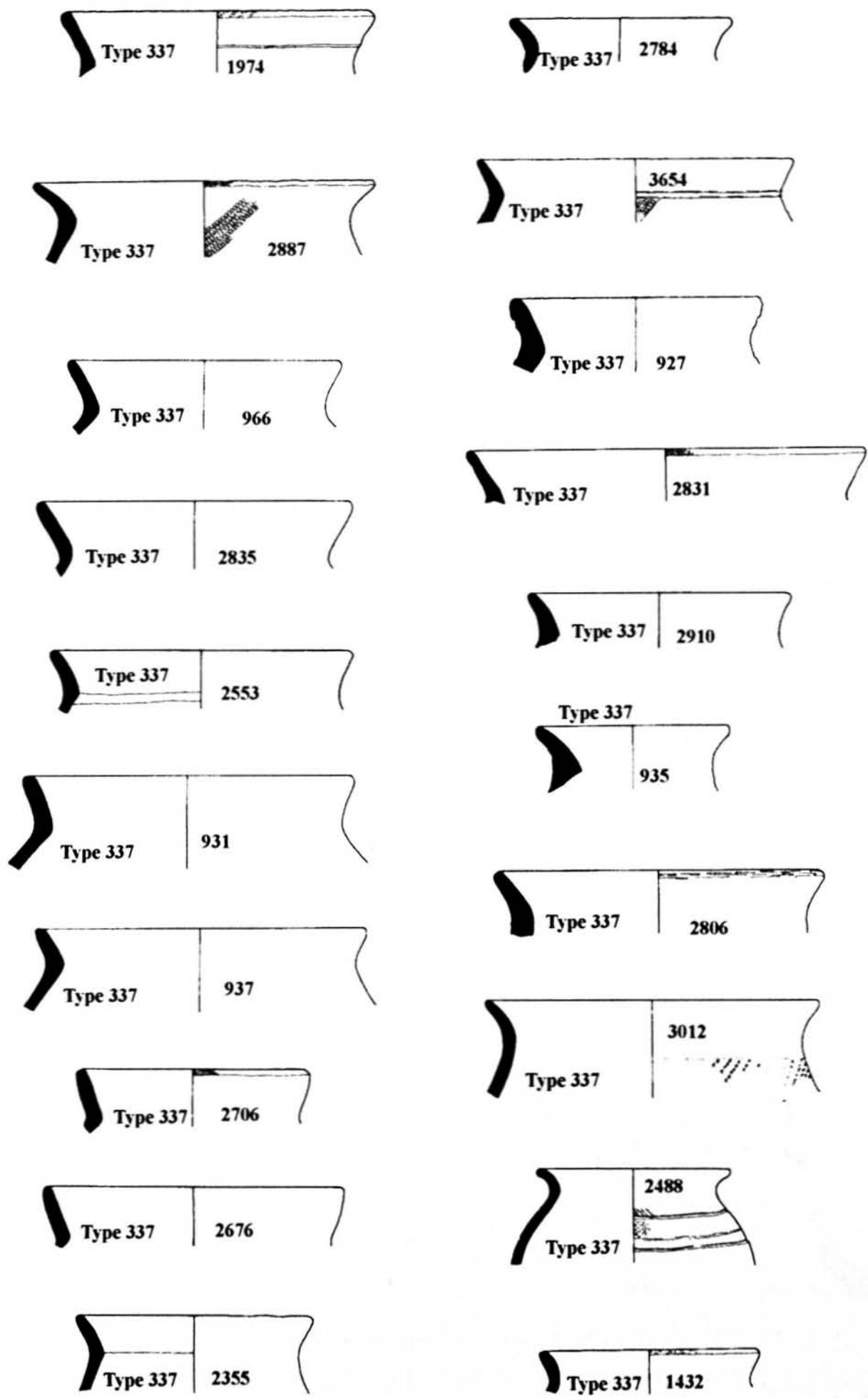

Figure 41.45. Handmade type 337. 1:4.

3439	Jarma area?	
------	-------------	--

Types 337-340. Jars

These are very common types. They are characterised by everted rims and globular bodies. They are commonly decorated with cord impressions, although incised lines and paint can also occasionally be found. They are very common at Sāniat Jibril (GER 002) and in 1st- to 4th-century levels at GER 001.

Type 337. Jar

Globular jar, simple everted rim; the rim is of constant thickness or tapering but not thickened or beaded; for the most part the rim is straight but in some cases it is outcurved.

CMD No	Context	Other information
1974	CHA 001	Berber red
	CHA 001	
	ELH 005	
	ELH 006	
	ELH 006	
	ELH 008	
3012	FJJ 006	Berber red
935	GER 002 (1, 4);	Berber red; RTHM 7/ ø 14 cm
931	GER 002 (1, 3)	Berber red/ ø 24 cm
927	GER 002 (1, 3);	Berber red; RTHM1/ ø 18.5 cm
2706	GER 002 (2, 76)	Berber red/ ø 16.7 cm
2676	GER 002 (2, 76)	Berber red/ ø 21.5 cm
2910	GER 002 (2, 76)	Berber red; RTHM1; RTHM3/ ø 19cm
2835	GER 002 (2, 27)	Berber red/ ø 23 cm
2553	GER 002 (4, 88)	Berber red/ ø 22.2 cm
966	GER 002 (4, 2/6)	Berber red/ ø 20 cm
2895	GER 002 (4, 92)	No fabric description
2831	GER 002 (6, 24)	Berber red/ ø 29 cm
2461	GER 002 (6, 14)	Berber red/ ø 15 cm
2488	GER 002 (6, 14)	Berber red; RTHM3/ ø 18 cm
2598	GER 002 (6, 19)	Berber red/ ø 28 cm

2887	GER 002 (6, 21)	Berber red / ø 25 cm
2784	GER 002 (6, 24)	Berber red/ ø 16.4 cm
CMD No	Context	Other information
2806	GER 002 (6, 24)	Berber red/ ø 24 cm
2355	GER 002 (7, 1)	Berber red; RTHM1/ ø 17.4 cm
2772	GER 002 (7, 24)	Berber red/ ø 19.3cm
937	GER 002 (1, 4)	Berber red; RTHM3, RTHM2/ ø 24.3 cm
	GER 027	
	GSC 006	
	LEK 017	
	RUG 021	
3654	TIN 001	Grey fabric
1432	ZIN 013 (39)	Zinkekrä fabric/ ø 15.6 cm Phase Z2

Type 338. Jar

Globular jar, straightish or outcurved everted rim, with a beaded lip.

CMD No	Context	Other information
	CHA001	
	GER 002	
933	GER 002 (1, 1)	Berber red/ ø 24 cm
922	GER 002 (1, 4)	Berber red/ ø 23 cm
930	GER 002 (1, 3)	Berber red/ ø 19.4 cm
921	GER 002 (1, 4)	Berber red/ ø 23 cm
2853	GER 002 (2, 67)	Berber red/ ø 19 cm
2608	GER 002 (2, 67)	Berber red/ ø 17 cm
2911	GER 002 (4, 101)	Berber red/ ø 19 cm
2674	GER 002 (6, 21)	Berber red/ ø 18 cm
2394	GER 002 (6, 10)	Berber red; RTHM4; RTHM 3/ ø 24 cm.
2704	GER 002 (6, 19)	Berber red/ ø 17 cm
2695	GER 002 (6, 21)	Berber red/ ø 14.2 cm
2840	GER 002 (6, 24)	Berber red/ ø 18.2cm
2822	GER 002 (6, 24)	Berber red; RTHM3/ ø 29 cm
2623	GER 002 (6, 9)	Berber red/ ø 16 cm

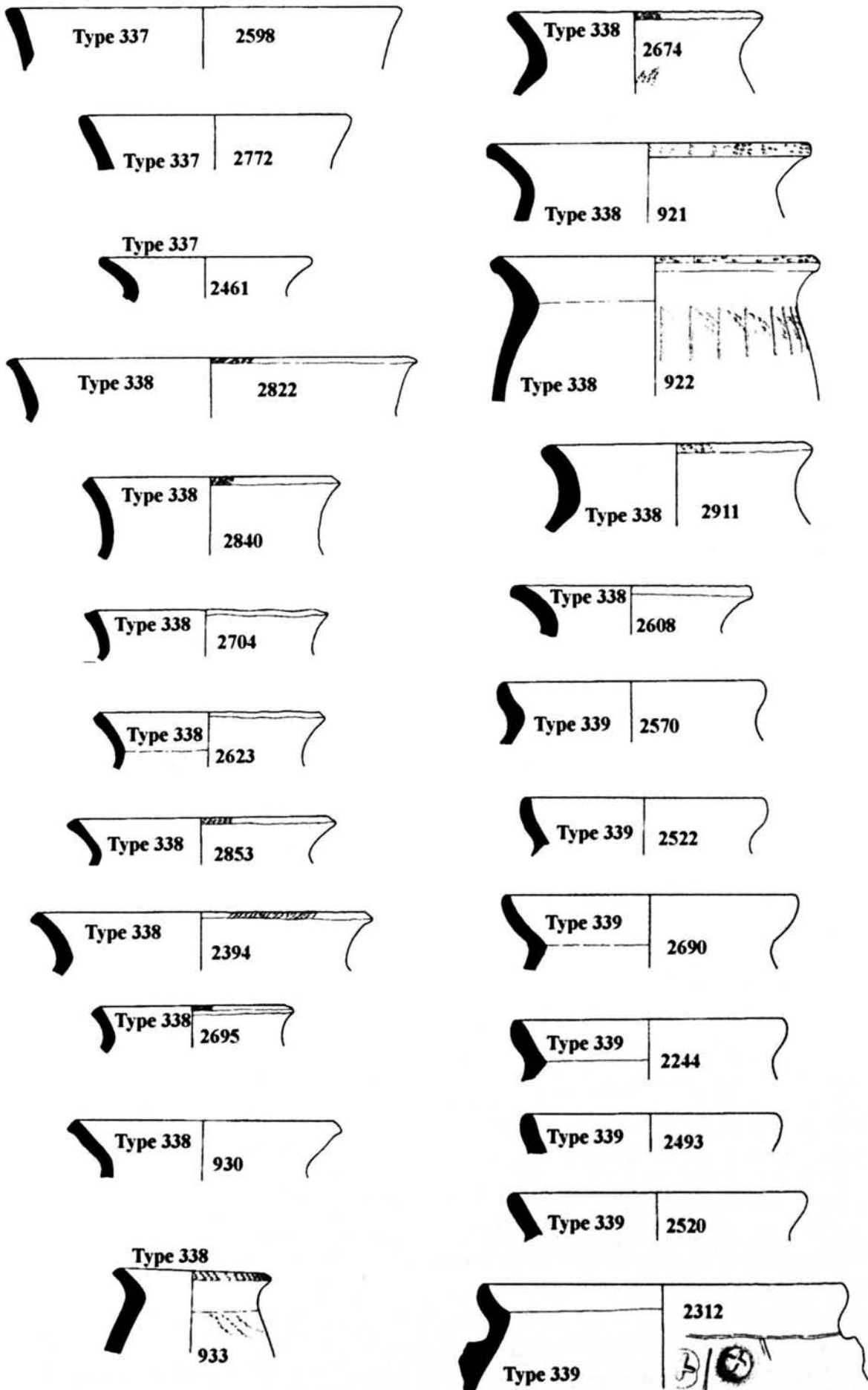

Figure 41.46. Handmade types 337 (cont)-339. 1:4.

	GER 016	
	RUG 022 (2)	

Type 339. Jar

Globular jar, everted rim; the whole rim is essentially 'cupped' to seat a lid.

CMD No	Context	Other information
	CHA 026	
2570	GER 002 (2, 67)	Berber red/ ø 18.5 cm
2690	GER 002 (2, 77)	Berber red/ ø 20.5 cm
2244	GER 002 (2, 13)	Berber red/ ø 19.5 cm
2493	GER 002 (2, 57)	Berber red/ ø 18 cm
2520	GER 002 (2, 57)	Berber red; RTHM3/ ø 20.5 cm
2522	GER 002 (2, 57)	Berber red; RTHM1; RTHM3/ ø 17cm
2312	GER 002 (4, 26)	Hbrp fabric/ ø 25.5 cm
	GER 004	
	GER 004	

Type 340. Jar

Globular jar, rim more markedly everted than 337-339; the upper face of the rim is slightly relieved to seat a lid.

CMD No	Context	Other information
2269	GER 002 (1, 1)	Berber red
2541	GER 002 (2, 57)	Berber red/ ø 20 cm
2845	GER 002 (6, 24)	Berber red/ ø 22.4 cm
2572	GER 002 (6, 9)	Berber red/ ø 17 cm/
3642	TWE area	Dark fabric with white flecks

Type 341-343. Dokas

This type has been recorded in many parts of North Africa. The examples listed below come mainly from Sāniat Jibril, but vessels are also known from Zinkekrā, where they are likely to date to the 1st century BC or 1st century AD. A more precise chronology should be available after full

study of the pottery from the Fazzān Project's excavations at GER 001. The type seems to have appeared in Roman period, and it was very common from the 2nd-3rd century AD and particularly in the early Medieval period (it seems to be absent from later Medieval and Modern contexts). In the Sudan the type does not seem to appear before the 1st millennium AD (Edwards 1996, 74) and thereafter is found in all periods after the Meroitic (Adams 1986, 158). Sudanese dokas are never decorated (Adams 1986, 158), but one of the fragments from the excavations at GER 001 bears a painted decoration, with red lines and dots on a white surface (with some traces left on the rim).

It has been suggested from the absence of specific ovens for bread-making that dokas were used to cook bread (Edwards 1996, 75). The bases of our vessels, however, show clear impressions of straw matting but no indications of direct contact with fire. We might suggest, therefore, that the food was cooked by locating the vessels in the vicinity of the source of heat rather than placing it directly on the fire. The presence of decoration might suggest that they were used to serve food.

Three sub-types can be distinguished:

Type 341 is very shallow with a barely developed lip.

Type 342 has a plain, upturned flange rim.

Type 343 has a more or less developed bead and flange rim.

Type 341. Doka

All examples are from ZIN 013 or TIN 001.

CMD No	Context	Other information
3655	TIN 001	Berber red
3638	TIN 001	Brown fabric with quartz
3673	TIN 001	Grey fabric
1099 [DZ 25]	ZIN 013	No fabric description

Type 342. Doka

Most examples are from GER 002.

CMD No	Context	Other information
2347	GER 002 (7, 2)	No fabric description
2286	GER 002 (7, 2)	Hbf/ ø 23.4 cm Phase Z2

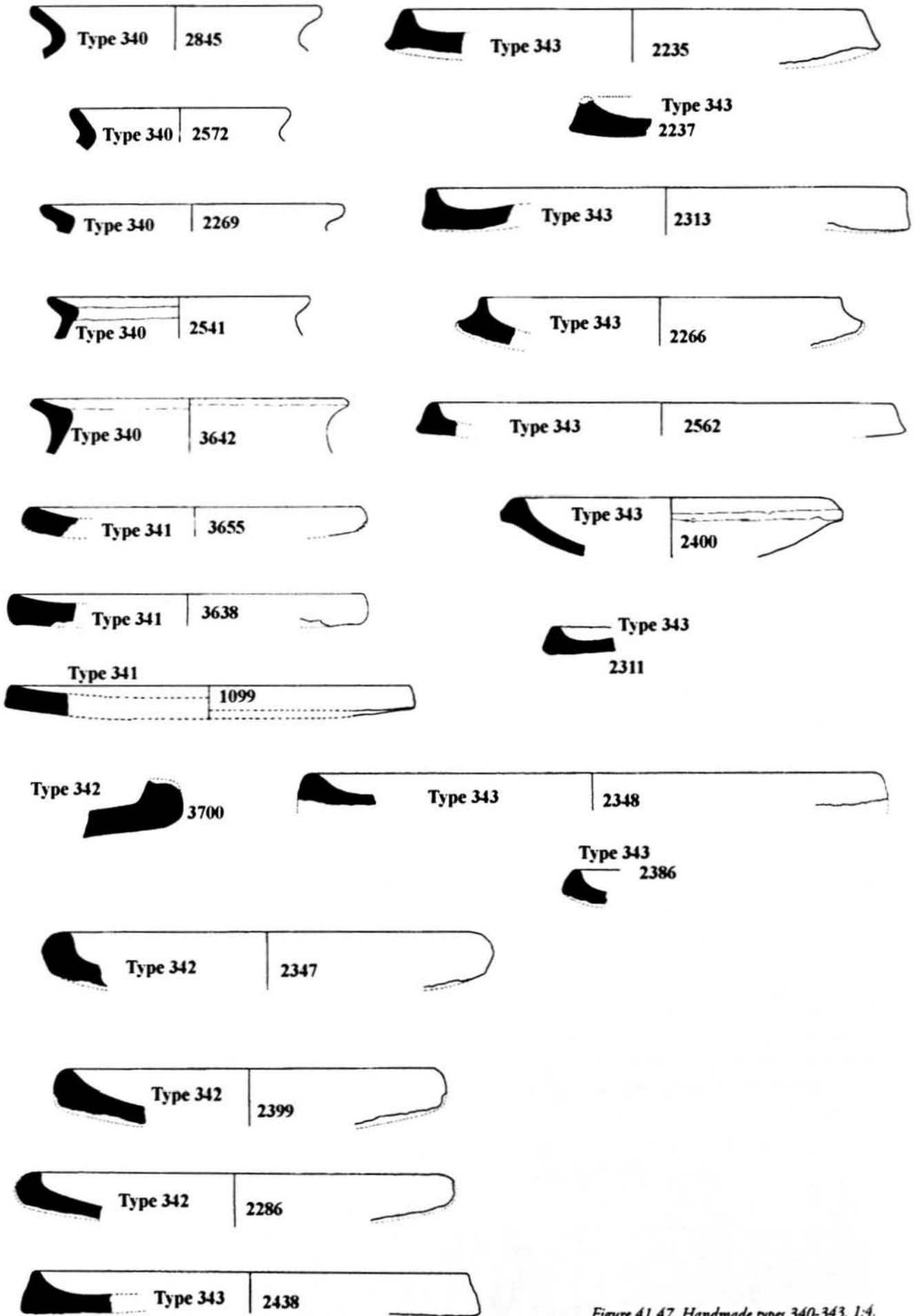

Figure 41.47. Handmade types 340-343. 1:4.

2399	GER 002 (4, 26)	No fabric description
3700	TIN 001	Berber red

Type 343. Doka

Most examples are from GER 002.

CMD No	Context	Other information
	ELH 006	
	ELH 005	
2531	GER 002 (2, 28)	Hblf/ ø 24.4 cm
2313	GER 002 (2, 3)	Hb Phase 1
2438	GER 002 (2, 33)	Berber red/ ø 33 cm Phase 2
2562	GER 002 (2, 56)	Hblf/ ø 35 cm Phase 2
2235	GER 002 (4, 26)	Hb. Phase 3
2266	GER 002 (4, 13)	Brown fabric with white flecks
2311	GER 002 (4, 13)	Hg; RTHM5
2386	GER 002 (4, 19)	Black fabric
2348	GER 002 (4, 26)	Hblf; RTHM3/ ø 43.6 cm. Phase 3
2400	GER 002 (4, 26)	No fabric description
	GER 016	

Type 345-348. Bowls and dishes with plain rims

Occurrence of the majority on GER 002 suggests a date range of 1st – 4th century AD.

Type 345. Small Bowl

Small hemispherical bowls with plain rim.

CMD No	Context	Other information
	GBD 002	
2505	GER 002 (2, 38)	Berber red; RTHM3/ ø 20.5 cm. Phase 3
2809	GER 002 (4, 100)	Berber red/ ø 21 cm. Phase 2
2411	GER 002 (4, 26)	Berber red; RTHM3
2317	GER 002 (6, 2)	Berber red; RTHM1
	GER 026	
	ZOU 001	
	ZOU 001	

Type 346. Small to Medium Bowl or Dish

Small and medium bowls and dishes. The upper wall is generally straighter than in previous type. There is a suggestion of a carination in the wall of some of them. The lip of the rim is also very slightly thickened in many of the examples – to the extent of developing a very slight bead on many of them.

CMD No	Context	Other information
	BBA 015	
	CHA 001	
	CHA 001	
3017	FJJ 006	Berber red
	GBD 021	
	GEL 027	
2248	GER 002 (2, 11)	Black fabric; RTHM 1
2468	GER 002 (2, 33)	Berber red
2557	GER 002 (4, 65)	Berber red; RTHM3/ ø 29 cm. Phase 2
2240	GER 002 (4, 26)	Berber red/ ø 25cm. Phase 3
2637	GER 002 (4, 30)	Berber red
2848	GER 002 (4, 24)	Black fabric
2670	GER 002 (6, 9)	Berber red/ ø 28.8 cm. Phase 2
2377	GER 002 (7, 1)	Berber red; RTHM 12. Phase 2
2388	GER 002 (7, 2)	Berber red

Type 347. Small to Medium Bowl or Dish

Small and medium sized bowls and dishes in which the lips of the rims are developed in some way, either thickened, beaded or moulded. All of them are quite similar in size and general shape.

CMD No	Context	Other information
3433	CLF 008	Berber red
2851	GER 002 (4, 24)	Berber red; RTHM3; RTHM 12
979	GER 002 (4, 1, 4-5)	Berber red
2358	GER 002 (4, 26)	Berber red; RTHM3/ ø 19 cm. Phase 3
2662	GER 002 (6, 9)	Berber red
	GER 004	
3848	GRE 001	Dark fabric
	RUG 022	

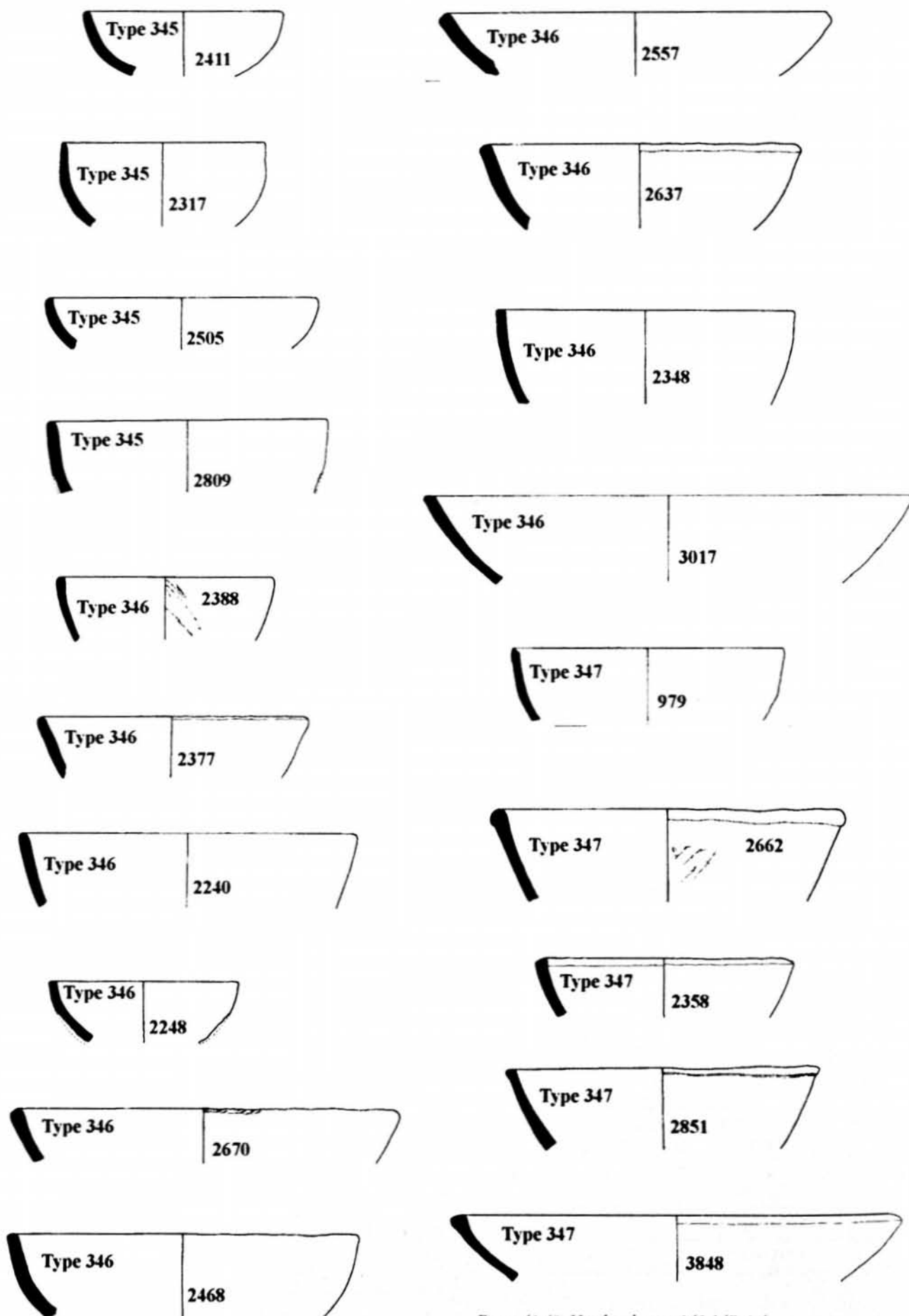

Figure 41.48. Handmade types 345-347. 1:4.

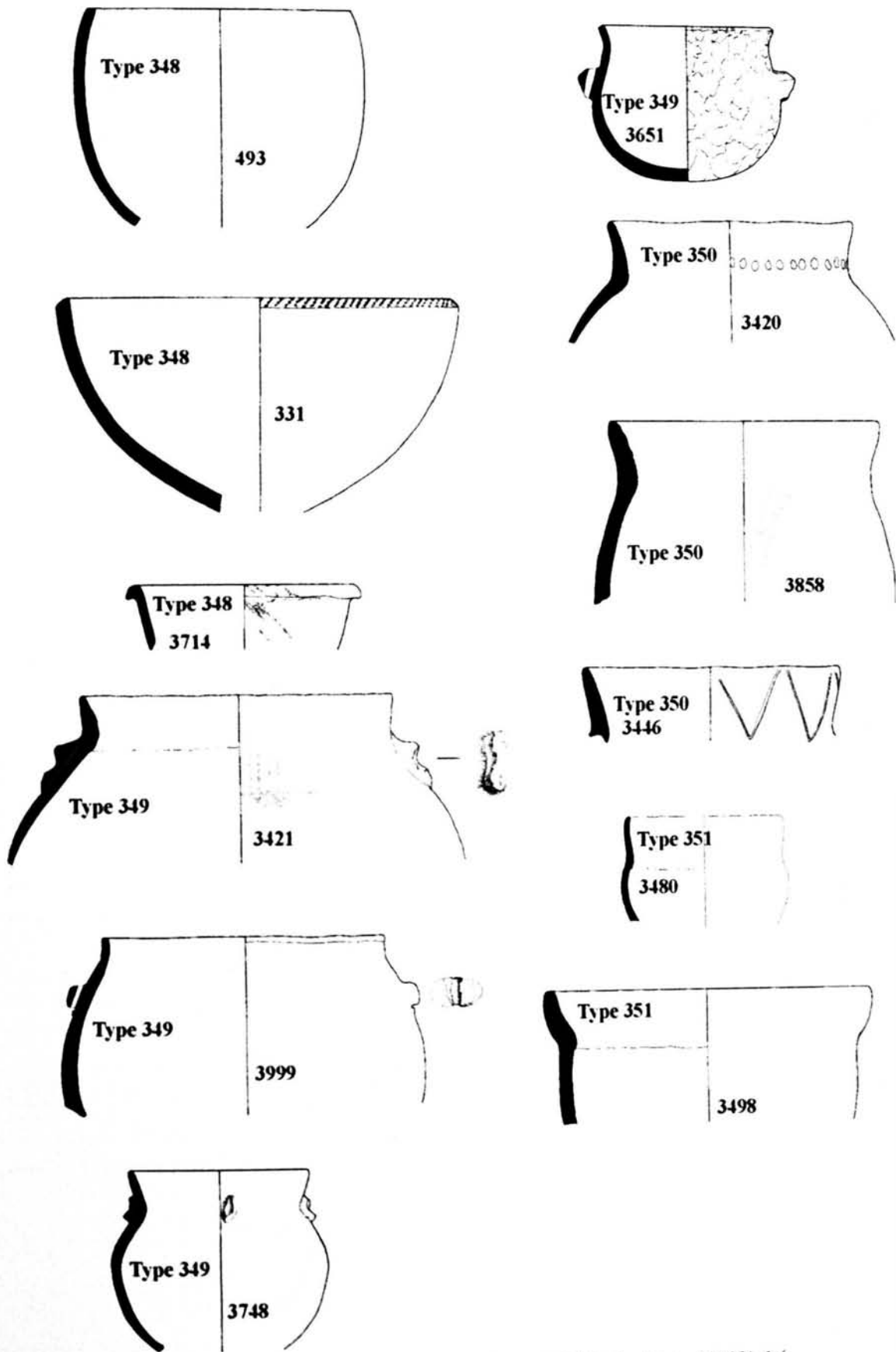

Figure 41.49. Handmade types 348-351. 1:4.

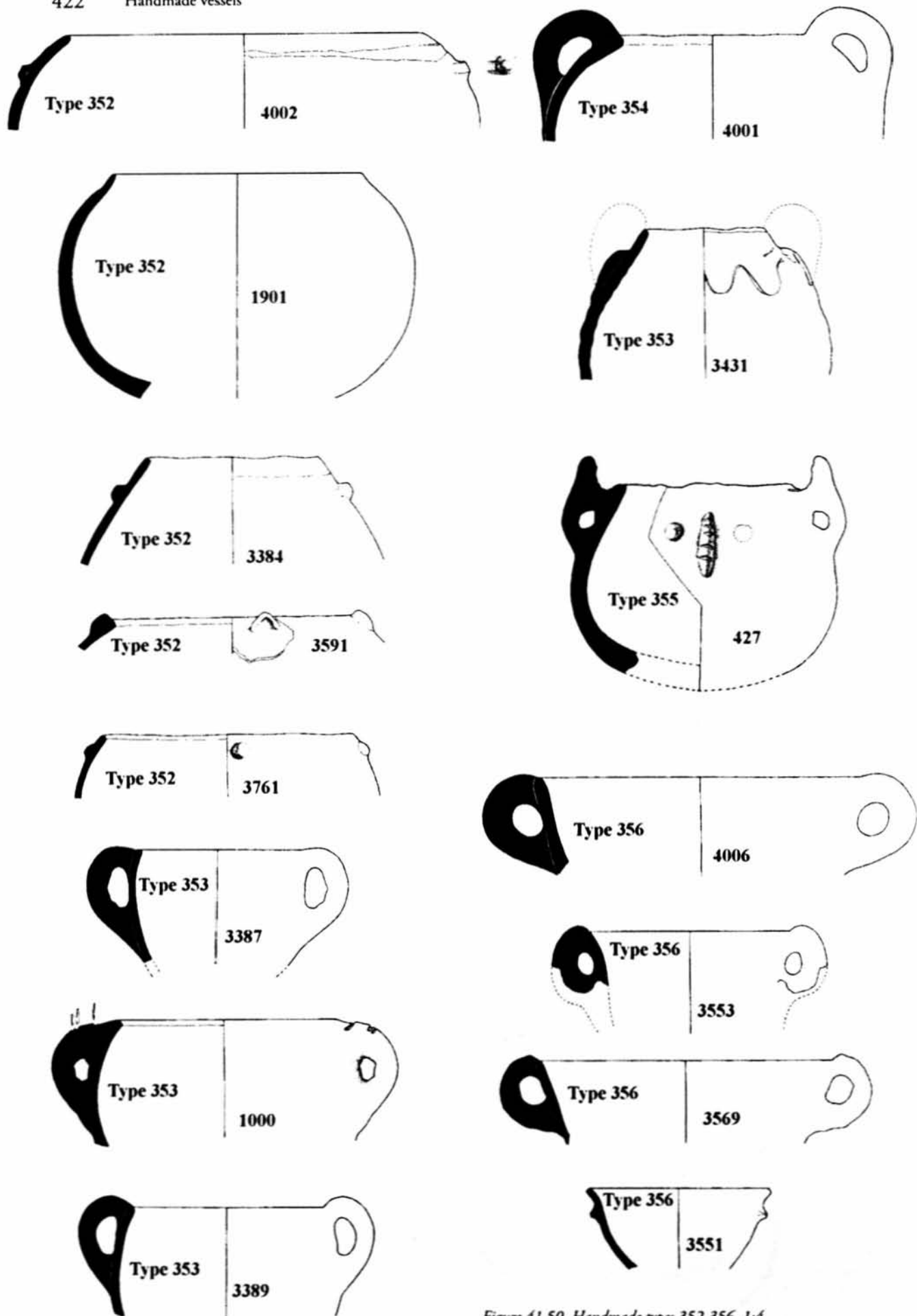

Figure 41.50. Handmade types 352-356. 1-4.

	ZOU 001	
	ZUL 010	

Type 348. Miscellaneous Vessels

Miscellaneous vessel not assigned elsewhere

CMD No	Context	Other information
331	FJJ 002	No fabric description
493 (JD)	ZIN 001-003	No fabric description
3714	ZOU area	No fabric description

Types 349-360 Possibly post-Garamantian forms

The occurrence of these types in the upper stratigraphy of the Fazzān Project's excavations at GER 001 suggests that they may be of Islamic or early modern date (i.e. 15th – 20th century), though many of the sites where surface finds were collected are in fact Garamantian. It is conceivable that future excavation will confirm a Garamantian origin for some of them. The issue will be more fully discussed in the publication of the pottery from the Jarma (G1) excavations in *AF 4*.

Type 349. Jar

Miscellaneous Everted rim jars, possibly Islamic or Early Modern.

CMD No	Context	Other information
3421	CLF 002	Grey fabric
	FJJ 006	
3999	LEK 001	Grey fabric with quartz and white chalk
3748	RUG 003	Black berber fabric
3651	TIN 001	Berber red

Type 350. Jar

Miscellaneous Everted rim jars, possibly Islamic or Early Modern.

CMD No	Context	Other information
3420	CLF 002	Blackish fabric
3446	CLF 002	Dark fabric with white chalk

3056	FUG 003	Berber red
3858	GRE 001 (176)	Black fabric with quartz

Type 351. Jar

Jars with tall rims for lid-seating.

CMD No	Context	Other information
3444	CLF 002	Black fabric
3480	ZOU area	Berber red
3498	ZOU area	Berber red

Type 352. Jar

Miscellaneous deep jars with inturned rims.

CMD No	Context	Other information
3761		
3384	CLF 002	Blackish grey hard fabric
	ELH 006	
1901	FUG 001	Black fabric with white chalk
4205	FUG 009	No fabric description
	GER 003	
4002	LEK 001	Dark, black fabric
3591	TIN 001	Berber fabric, black grits, white chalk
1276 [DZ 295]	ZIN 087	Berber red; RTHM3

Type 353. Deep Jar

Deep jars with slightly inturned rims and large, lug handles.

CMD No	Context	Other information
3389	CLF 002	Black ashy fabric
3387	CLF 002	Black berber fabric
1000	TWE 001	Grey fabric

Type 354. Jar

Jars with markedly in-turned rims and large, lug handles upstanding above the rim.

CMD No	Context	Other information
--------	---------	-------------------

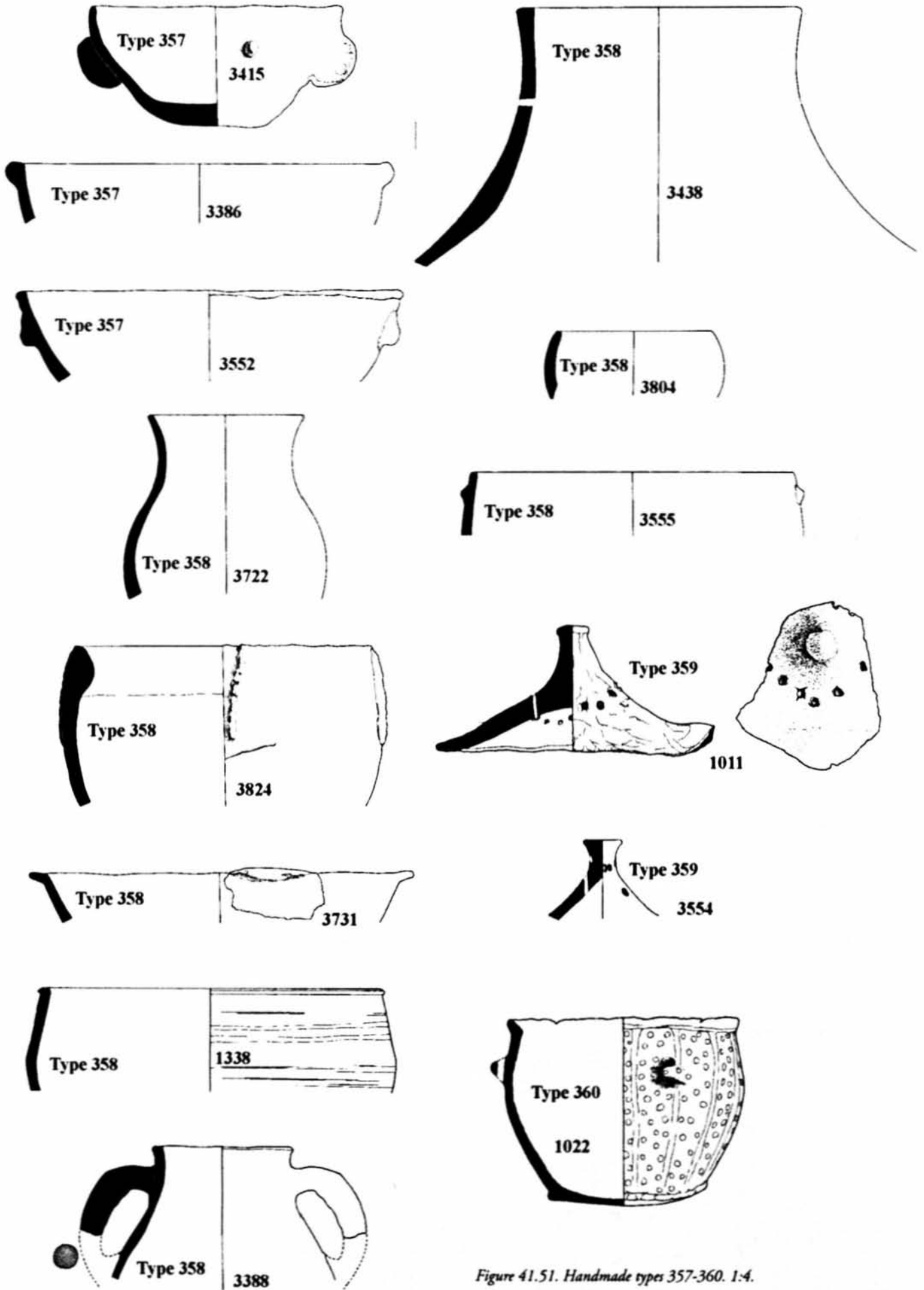

Figure 41.51. Handmade types 357-360. 1:4.

3431	CLF 002	Dark grey fabric
4001	LEK 010	Grey fabric with white chalk

Type 355. Jar

Round-bottom jars with inturned rims and large handles with peaked lugs - 'Genie Pots'. These vessels have a 'face' on the outer wall consisting of an elongated lug between two round lugs.

CMD No	Context	Other information
	GER 015	
	GER 027	
	GER 002	
3790	TAG 020	
427	ZIN 109 (12)	Berber red; RTHM3
671	ZIN 280 (1)	Zinkekrå fabric/ ø 14.8 cm

Type 356. Bowl

Handled bowls with ring handles

CMD No	Context	Other information
3569	GBD 002 (26)	Berber red fabric with white chalk
3553	GEL 002	Black berber red fabric
3551	GEL 002	Black berber red fabric
4006	LEK 001	Berber red

Type 357. Bowl

Handled bowls with lug handles.

CMD No	Context	Other information
3886	CLF 002	Grey fabric
3415	CLF 002	Berber red
3552	GEL 002	Berber red black hard fabric

Type 358. Miscellaneous Jars or Bowls

CMD No	Context	Other information
3804	CHA 007 (S)	No fabric description
CMD No	Context	Other information
3438	CLF 002	Berber grey fabric
3388	CLF 002	Black berber fabric
3423	CLF 002	Grey fabric
3555	GEL 003	Black fabric with white chalk
1338	GSC 002	Dark fabric
3824	LEK 009	Berber red
3722	RUG 001 (G)	No fabric description
3731	RUG 001	Berber red
432 (JD)	ZIN 001-003	Non fabric description
495	ZIN 105 (5)	Black fabric

Type 359. Lids

CMD No	Context	Other information
	CHA 031	
	ELH 005	
	ELH 006	
4204	FUG 009	Berber red
3558	GEL 004	Berber red
1101	ZIN 001-003	Berber red; RTHM1

Type 360. Jar

Everted rim jar with painted decoration. This kind of decoration only appears in the post-medieval levels of the excavations at GER 001. The decoration is very consistent and consists of dots and straight lines, either white on a red ground or red on a white ground.

CMD No	Context	Other information
1022	GSC 010 (SP)	

PART F. MESOLITHIC/ NEOLITHIC POTTERY

by J. N. Dore

Introduction

The assemblage consists of 41 fragments representing *c.* 22 vessels from 9 contexts. Table 41.15 shows the relationship between catalogue number and contexts. All except no. 5 were recovered from the surface.

Table 41.15. Contexts of recorded sherds of mesolithic/ neolithic pottery

Catalogue No.	Site/Context
1, 2	TWE 021
3, 4	EDU 005
5	EDS 015
6, 7, 8, 9	EDU 018
10, 11	EDU 022
12, 13, 14, 15	EDU 026
16	GER 030
17, 18	GER 033
19, 20, 21	GRA 002

Discussion

The evidential basis for the date assigned to each piece is presented below. Table 41.16 summarises this.

Table 41.16 Evidential basis for assigned dates of mesolithic/ neolithic sherds

Cat. No.	Date	Evidential Basis
2	Mesolithic	Decorative Type
21	?Mesolithic-Early Neolithic	Decorative Type
5	Middle Pastoral	Standard of Manufacture
7	Middle Pastoral	Standard of Manufacture
8	Middle Pastoral	Standard of Manufacture
1	Middle Pastoral +	Presence of neck
10	Middle Pastoral +	Complex form & Standard of Manufacture
13	Middle Pastoral +	Akākūs parallel
14, 17	Middle Pastoral +	Fabric parallel (no 13)
19	Middle Pastoral +	Presence of neck
9	Middle-Late Pastoral	Akākūs parallel

Cat. No.	Date	Evidential Basis
15	?Late Pastoral	Late Pastoral parallel from Akākūs
12	?Late Pastoral - Garamantian	Zinkekrā parallel
16	Unknown	
3	Unknown	
4	Unknown	
6	Unknown	
11	Unknown	
18	Unknown	
20	Unknown	

Mesolithic – Early Neolithic

Catalogue No. 2.

There are good early Holocene associations for this kind of decoration which is characterised by rounded waves of multiple-line rows produced by rocker combs. In Sudanese contexts Caneva (1987, 248) notes its use on unburnished pottery (as here) and its association with Mesolithic lithic tool-kits, and contrasts it with a later type, which is characterised by short and sharp waves of pairs of dotted lines produced by simpler, two-pronged, alternately pivoting stamps, and found on burnished pottery associated with Neolithic assemblages. In the Wān Afūda cave in the Tadrart Akākūs the type appears in the later of two early Holocene occupations (characterised by the excavators as 'Mesolithic' or 'Late Akākūs' Hunter-Gatherers) dated to 9000-8000 BP (di Lernia 1998, fig. 15, no. 4). At Nabta Playa, recent work has recovered 'Dotted Wavy Line' pottery from Early Neolithic contexts (Nelson *et al.* 2002). Its earliest associations at Nabta seem to be with the El Nabta phase (Gatto 2002, table 5.5 and table 5.7 where the context is associated with a C¹⁴ date of 7785 bp +/- 115. Nelson 2002, fig. 2.1 showing the type present in the El Ghorab phase seems to be an error to judge from the evidence presented in the rest of the volume).

Catalogue No. 21.

The closely packed horizontal bands of rocker-stamped decoration suggest an early date for this piece. Similar packed decoration occurs on pottery from the Mesolithic/ Late Akākūs horizon at Wān Afūda (di Lernia 1998, figs. 15 and 16). In the Nabta-Kiseiba area of the Eastern Sahara a similar decorative scheme ('Halina' type) seems to be restricted to deposits of the El Nabta phase dated to the 8th millennium bp (Gatto 2002, tables 5.5 and 5.7).

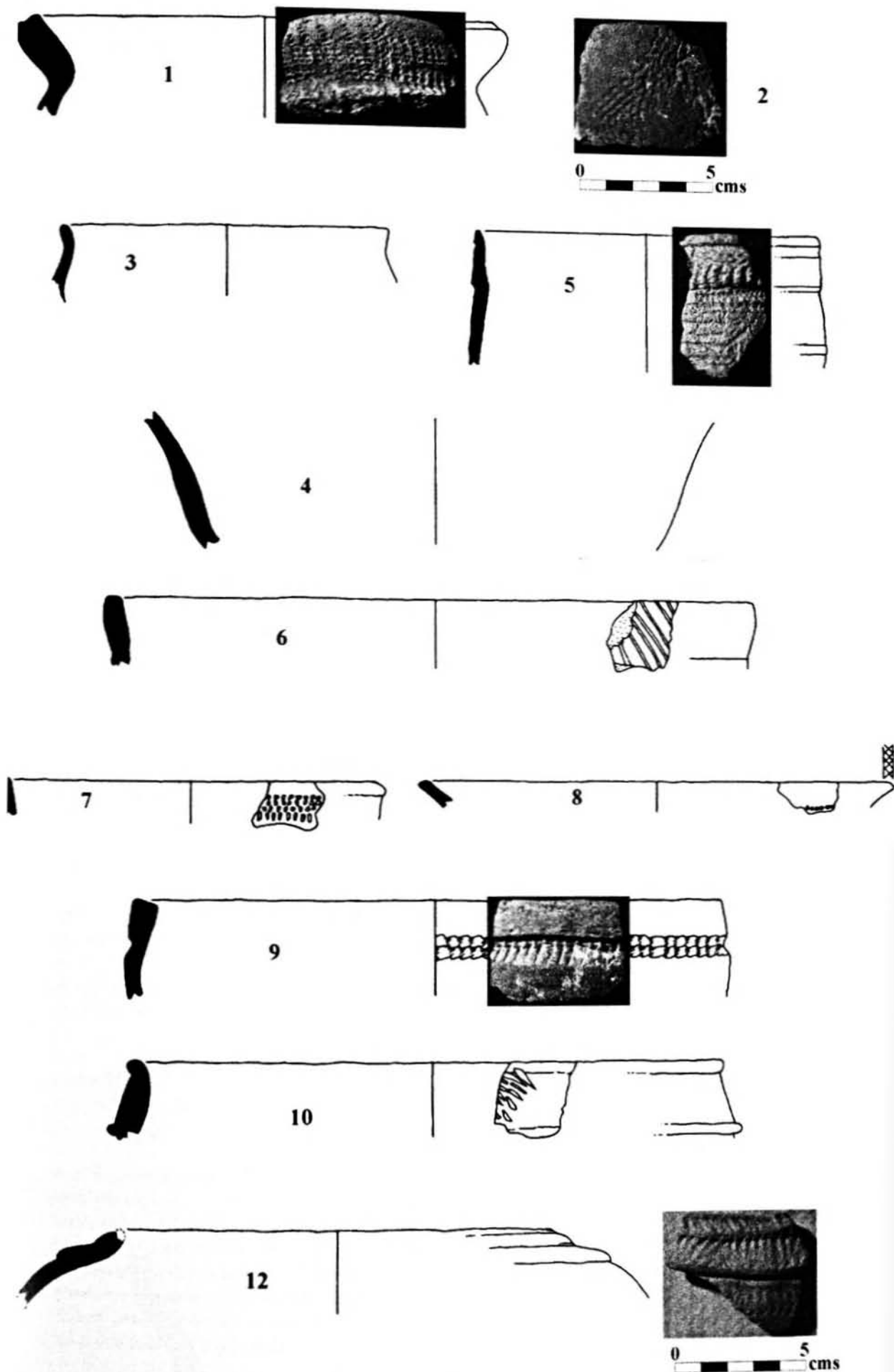

Figure 41.52. Mesolithic/Neolithic pottery. Cat. Nos. 1-12. 1:2.

Middle Pastoral (+)

Catalogue No. 5.

The thinness of the fabric, the use of a complex form and high standard of manufacture suggest that this vessel dates at least to the Middle Pastoral phase. Similar vessel forms and similar schemes of packed rocker decoration are known from the Wān Talikīt rock-shelter in the Tadrart Akākūs where the principal pottery bearing levels are dated to the 6th millennium BP (Garcea and Sebastiani 1998, fig. 7 and fig. 8, no. 1).

Catalogue Nos. 7. and 8.

These are quite small sherds but as with no. 5, the thinness of the fabric and high standard of manufacture suggest that they date at least to the Middle Pastoral phase

Catalogue No. 1.

There are indications that the introduction of necked forms does not occur until at least the 6th millennium BP (Ponti *et al.* 1998, 191). Similar everted-rim jars with grooved lips occur at Zinkekrā in a not dissimilar fabric (Daniels 1968, no. 302).

Catalogue No. 10.

The complex vessel form and high standard of manufacture suggests at least a Middle Pastoral date.

Catalogue No. 13.

Vessels with the same distinctive attributes (constricted girth; tall, flaring mouth; two narrow horizontal bands of plain rocker impression just below the constriction) are known from Middle Pastoral contexts in the Tadrart Akākūs (Cremaschi and di Lernia 1998, fig. 41).

Catalogue Nos. 14. and 17.

The style of manufacture (thickness of the vessels wall and the fabric colour and texture) is very similar to no. 13.

Catalogue No. 19.

The necked form of the vessel rim seems unlikely to date to before the Middle Pastoral (see no. 1), though these sherds possess certain attributes (relative thickness and exclusive use of rocker technique) which have been identified by di Lernia (1998, 138) and Ponti *et al.* (1998, 198) as more characteristic, in the ceramic assemblages of the Tadrart Akākūs, of the Mesolithic and early Pastoral than of the Middle and Later Pastoral.

Middle – Late Pastoral

Catalogue No. 9.

Similar deeply impressed plain rocker decoration is known on vessels from the Wān Talikīt rock-shelter in the Tadrart Akākūs where the principal pottery bearing levels are dated to the 6th millennium BP (Garcea and Sebastiani 1998, fig. 8, no. 8). Similar bowls with inturned and

thickened rims are common in the Zinkekrā assemblage (Daniels 1968).

Late Pastoral

Catalogue No. 15.

Close examination of the sherd suggests that the decoration was formed by repeated impressions of a short, straight edge in the wet clay, rather than by impressing, pivoting, and impressing again to produce each chevron, the technique which Nelson (2002, 13) suggests was used in the generation of the 'Woolfthooth' decorative style dated to the early Neolithic in the Nabta-Kiseiba area. Cremaschi and di Lernia 1998b, fig 44, no. 1 shows a Late Pastoral sherd from the Akākūs bearing a similar horizontal band of simple diagonal impressions from a short, straight edge.

Catalogue No. 12.

Similar vessels with bands of packed zig-zag rocker on the lip of the rim are common in the Zinkekrā assemblage (Daniels 1968, nos. 79, 170, 340, 341).

Catalogue

1. TWE 021. [FP 1998]. Rim sherd of jar. Diameter at rim 180mm. Thickness of wall below rim: 5.5mm. Sandy black fabric, orange-brown outer surface, black inner surface. Inclusions: abundant rounded quartz mainly ≤ 0.1 mm, some up to 0.5mm. Packed zig-zag rocker impressions on external surface.
2. TWE 021. [FP 1998]. Wall sherd. Average thickness 5mm. Sandy black fabric. Unburnished external surface decorated with an undulating band of rocker stamping ('dotted wavy-line' rocker).
3. EDU 005. [FP 2001]. Small rim sherd – possibly wheel-made. Diameter at rim: 120mm. Average thickness of wall below rim: 5mm. Fine black, red-brown surface, heavily abraded and varnished. Inclusions: common rounded quartz mainly ≤ 0.1 mm, some 0.2-0.5mm and occasionally up to 2.0mm.
4. EDU 005. [FP 2001]. Wall sherd, possibly from a bowl. Average thickness of wall 7mm. Fabric as previous but slightly sandier.
5. EDS 015. (Transect 03.5) [FP 2000]. Rim sherd from a small bowl. Diameter at rim: 130mm. Average thickness of wall is 4.5mm. Well made, fine black fabric, burnished dark red-brown surface. The outer surface is decorated with rocker technique. The zig-zag can clearly be seen just below the rim. Below this the impressions are very closely packed. Inclusions: common rounded quartz, mainly ≤ 0.1 mm, some 0.1-0.2mm, sparse rounded limestone mainly 0.1-0.2mm.

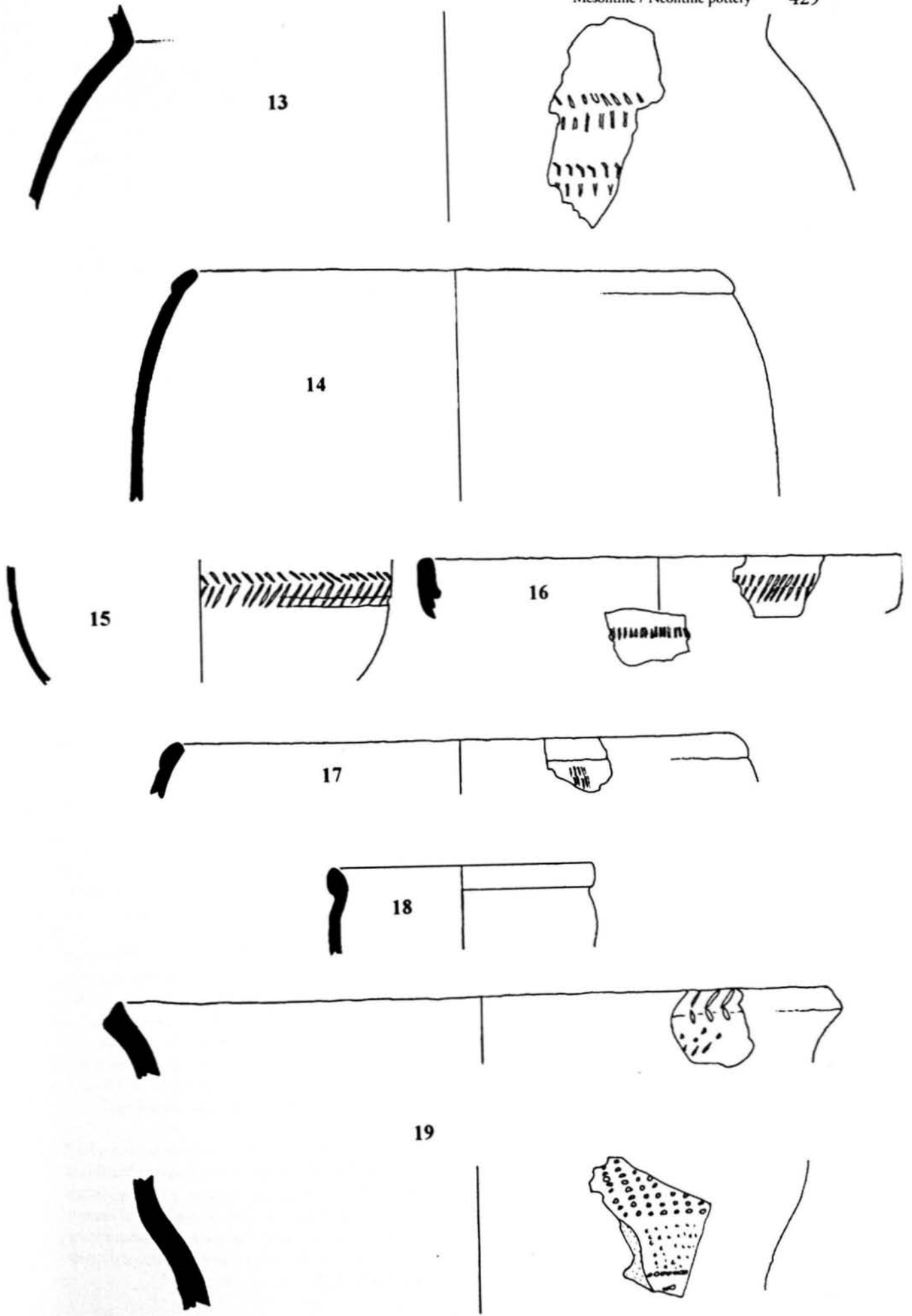

Figure 41.53 (left). Mesolithic/Neolithic pottery. Cat. Nos. 13-19. 1:2.

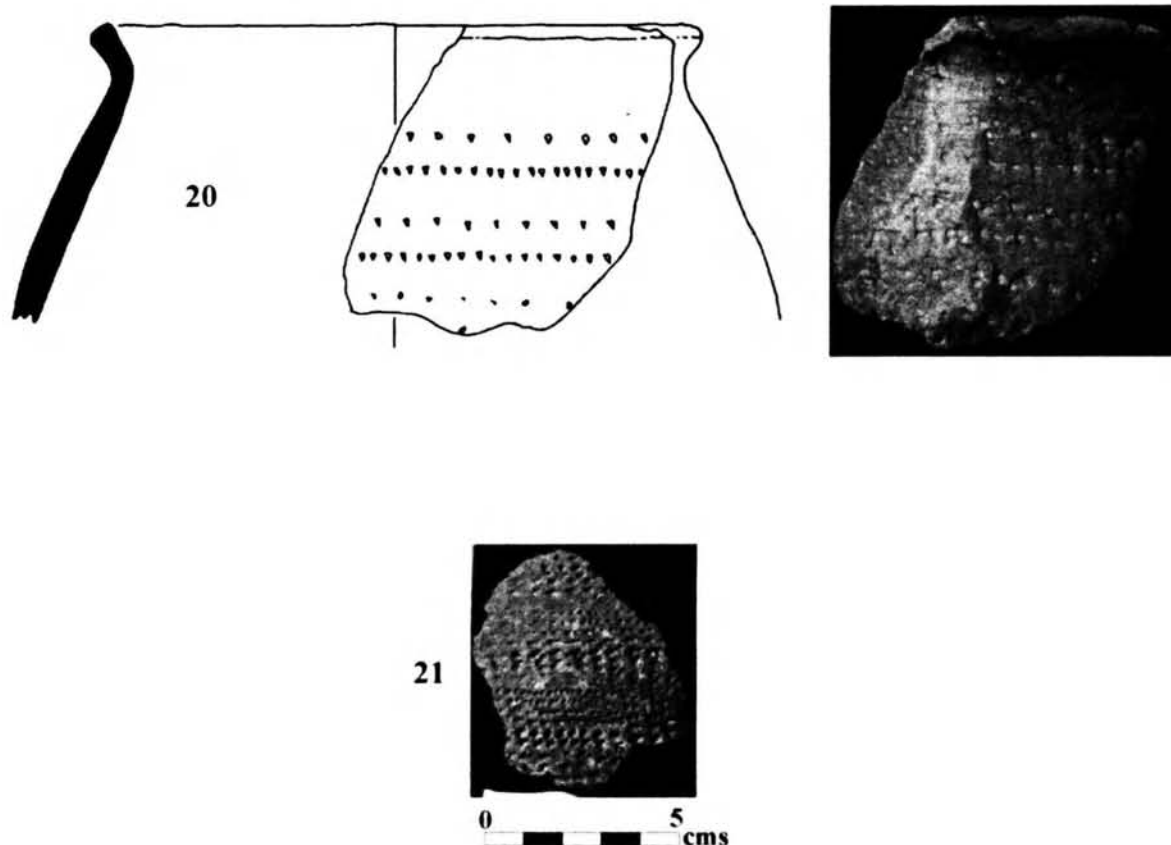

Figure 41.54. Mesolithic/Neolithic pottery. Cat. Nos. 20-21. 1:2.

6. EDU 018. [FP 2001]. Rim sherd. Diameter at rim: 240mm. Thickness of wall below rim: 7mm. Black fabric, burnished red-brown surface over a pale buff sub-surface margin. The outer surface is decorated with plain rocker zig-zags. Inclusions: sandy clay matrix, with rounded quartz, mainly 0.5-1.0mm, some 1-2.0mm; also some 'grog' and clay pellets.

7. EDU 018. [FP 2001]. Rim sherd. Diameter at rim: 140mm. Average thickness of wall: 3.5mm. Fine black fabric, burnished red-brown surface. Inclusions: discrete silty matrix with occasional quartz up to \approx 0.5mm. Impressed rocker decoration on external surface.

8. EDU 018. [FP 2001]. Rim sherd. Diameter at rim: 170mm. Average wall thickness: 2.5mm. Fabric as 7. Slight trace of rocker impression on external surface; diamond broached impression on lip.

9. EDU 018. [FP 2001]. Two rim sherds from a bowl. Diameter at rim: 220mm. Average wall thickness: 3.5mm. Sandy black, red-brown outer surface, black inner surface. Inclusions: rounded quartz up to 1.0mm, rock fragments, grog, clay pellets. The external surface carries a deeply impressed, narrow horizontal band of rocker motif.

10. EDU 022. [FP 2001]. Rim sherd. Diameter at rim: 220mm. Maximum wall thickness: 9.5mm. Sandy

black, with orange-brown outer surface and black inner. Inclusions: common quartz, mostly \leq 0.2mm, some up to 2mm. The external surface carries part of a diagonal band of rocker decoration.

11. EDU 022. [FP 2001]. Wall sherd (possibly same vessel as previous). Average thickness 6.5mm. Sandy black with orange-brown external surface. Inclusions: common quartz, mostly \leq 0.2mm, some up to 2mm; also fragments of flint up to 2mm. The external surface carries a horizontal band of plain rocker impression.

12. EDU 026. [FP 2001]. Lake on edge of sand-sea. Rim sherd from a jar. The lip of the rim is very abraded. Diameter at rim: 160mm. Wall thickness: 6mm. Sandy black fabric, dull red-brown surface. Inclusions: common quartz, \leq 0.1mm, sparse limestone, 0.1-0.2mm. The external surface of the rim moulding is covered with two horizontal bands of packed zig-zag rocker and there is another band clearly visible below the moulding.

13. EDU 026. [FP 2001]. Lake on edge of sand-sea. Wall sherd from a jar with flaring mouth. Average wall thickness 3mm. Well fired fine dark grey fabric with pale orange margins and red-brown surface. Inclusions: abundant well-rounded quartz mainly \leq 0.1mm, occasionally up to 0.5mm. The external surface has two horizontal bands of plain zig-zag rocker decoration.

14. EDU 026. [FP 2001]. Lake on edge of sand-sea. Rim sherd from a jar with an inturned rim with moulded lip. Diameter at rim: 220mm. Average thickness of wall: 3mm. Sandy pale orange fabric with dark grey core in places. Red-brown surface. Inclusions: abundant rounded quartz, mainly ≤ 0.1 mm, some up to 0.2mm and a little up to 0.5mm. Sparse rock fragments (? granite). The external surface is very abraded but there are faint traces of impressed rocker decoration.

15. EDU 026. [FP 2001]. Lake on edge of sand-sea. Wall sherd from a small bowl (?). Average wall thickness 3.5mm. Sandy dark red-brown fabric with dark grey core and red-brown surface. Inclusions: abundant rounded quartz, mainly ≤ 0.1 mm, some up to 0.2mm and a little up to 0.5mm. The external surface carries a horizontal band of nested chevrons.

16. GER 030. (grab). [FP 1999]. Rim sherd from small bowl. Diameter at rim: 200mm. Wall sherd probably from the same vessel. Average wall thickness: 4mm. Sandy black fabric, red-brown surface. Inclusions: common quartz mainly ≤ 0.1 mm, some up to 0.2mm and a little up to 0.5mm. The external surfaces of both pieces appear to be decorated with simple impression, the rim with a band of diagonals, the wall with an evenly serrated edge.

17. GER 033. (A2). [FP 1999]. Rim sherd. Diameter at rim: 230mm. Thickness of wall: 5mm. Gritty black with burnished red-brown surface. Inclusions: common

rounded quartz mostly ≤ 0.1 mm, a little up to 1.0mm. See Mattingly *et al.* 2003, 129, fig. 4.23.

18. GER 033. (A2). [FP 1999]. Rim sherd. Diameter at rim: 110mm. Thickness of wall: 4.5mm. The exterior wall below the rim is decorated with packed rocker motif. Sandy black with brown-buff surface; inclusions: common rounded quartz mostly ≤ 0.1 mm, a little up to 1.0mm. See Mattingly *et al.* 2003, 129, fig. 4.23.

19. GRA 002. [FP 2001]. Rim sherd and wall sherds probably representing at least two vessels. Diameter at rim: 290mm. Average wall thickness: 7.5mm. Sandy black with brownish-buff surface; inclusions: common sub-angular quartz mostly ≤ 0.2 mm. External surfaces carry zig-zag rocker decoration.

20. GRA 002. [FP 2001]. Rim sherd and five wall sherds probably all from the same vessel. Diameter at rim: 160mm. Average wall thickness: 9.5mm. Sandy black with dark brown surface. Inclusions: common rounded quartz mostly ≤ 0.1 mm, occasionally up to 1.0mm. External surfaces decorated with alternately pivoting stamp impressions (non-return).

21. GRA 002. [FP 2001]. Wall sherd. Wall thickness 8.0mm. Sandy black with red-brown surface. Inclusions: common quartz, mostly ≤ 0.1 mm, some up to 2.0mm. External surface decorated with packed rocker stamp.