

# ANALYSIS OF CONVENTIONAL SPINNING PROCESS OF A CYLINDRICAL PART USING FINITE ELEMENT METHODS

Seth Hamilton, Hui Long

School of Engineering, Durham University, Durham, DH1 3EL, United Kingdom

## ABSTRACT

This paper studies the material deformation mechanism and typical cases of material failure in conventional metal spinning. The non-linearity of structural mechanics exhibited in spinning process is addressed and key considerations in performing effective Finite Element simulations of metal spinning are discussed. Using explicit Finite Element method and employing load rate scaling and mass scaling techniques, this paper reports the development of Finite Element simulation models of a spun cylindrical part by a single-pass of the roller, with the intention to understand the effect of process parameters on the formed product and material deformation mechanisms leading to defects in the spun product. Key issues regarding effective simulation techniques of metal spinning process are also discussed.

**Keywords:** Conventional spinning; explicit FE method; load rate scaling; mass scaling.

## 1. INTRODUCTION

Metal spinning has seen its increased attention in recent years for applications in automotive, aerospace and medical industries [1]. The main advantages of the metal spinning process include low tooling costs, reduced forming loads, flexibility and near net shape production for various geometrical configurations therefore requiring less process development time and cost for customised products as compared to alternative processes.

Despite the conceptual simplicity, determination of process parameters and controllability of product quality remain challenging tasks. These process parameters including roller path and number of passes, feed ratio

and spinning ratio are interdependent. For different products, the material type, thickness, geometrical configuration and dimensions may vary and thus require different settings of process parameters so as to ensure good quality and high efficiency in production.

In the present industrial production, the trial and error approach is still commonly used in the development of a new spun part. It inevitably results in significant variations and discrepancies in product quality and geometrical dimensions and, in some cases, failures such as wrinkles and cracks occur due to inappropriate process design. In practice, the whole procedure of metal spinning process development and validation is costly and time consuming, often regarded as the black art by engineers and operators. Due to limited publication in literature, it is difficult to access useful data of material formability in spinning and there is no practical guidance on how to effectively develop metal spinning processes. Investigations based on experimental, analytical and Finite Element (FE) methods have been carried out to gain a better understanding on how process parameters influence product quality and process efficiency. The deformation mechanism of a spinning process has been studied by Kang et al. [2] through experiment and analysis. Three types of roller paths, i.e., straight line, concave and convex curves, have been investigated. They concluded that the deformation mode of the spinning of plates was mainly shear spinning and the wall thickness in the deformed area correlated well with the sine law. The deformation in the first pass had a decisive effect on the wall thickness distribution of the spun product. Quigley and

Monaghan [3] analysed radial and hoop strain distributions for a conventionally spun spherical part using both multi-pass and single-pass operations. Using experimental measurements and theoretical predictions, the results showed that the radial strain was significantly larger than the hoop strain. The differences between the measured and predicted hoop strains implied that there was a certain degree of shear forming in the first roller pass of conventional spinning. Kleiner et al. [4] have developed methods of statistical experimental design and non-linear time series analysis in combination with FE modelling of a spinning process so as to identify the causes of dynamic instabilities and to develop methods to prevent such types of failure. It was found that the axial feed of roller, the design and the number of roller passes as well as the angular velocity of the workpiece were most important parameters for causing wrinkling and other defects in the workpiece. Specifically it was suggested that a marginal change of roller passes would create wrinkles and part damage. Using experimental investigations, Xia et al. [5] studied one-pass deep drawing spinning of cups. Forming conditions considered in their research included the material property, the feed rate of the roller, nominal deep drawing ratio, and relative clearance between the roller and mandrel, which were found to be important parameters affecting the spinning force, nominal thickness strain and material formability. Wrinkles were prone to occurrence for thin blank thicknesses under large feed rates and relatively large clearances.

Finite Element Method has been successfully applied for metal forming process simulations and it provided an effective computational tool to investigate effects of process parameters on the product quality [6]. However, the complexity of the spinning process largely due to localized plastic deformation under multiple-passes of tool, kinematics and dynamic interactions between tools and workpiece has made the computational simulation of metal spinning

process very difficult. Quigley and Monaghan [7-8] discussed some important techniques in FE simulation of spinning processes. The authors suggested that the application of domain decomposition would enable the partition of a FE problem into sub-problems using parallel processing techniques to reduce computing times. Alberti and Fratini [9] discussed the advantages and differences between two FE methods, i.e. static implicit and dynamic explicit methods and their applications in sheet metal forming process simulations. Utilizing the explicit approach, the simulation of a shear forming of a conical shape was reported and the thickness distributions of the final spun part were obtained for 60° and 45° dies. The results were generally in agreement with the experimental measurements. In a recent paper by Liu [10], extensive simulation results have been obtained by applying the dynamic-explicit FE method of LS-DYNA. The multi-pass and die-less spinning processes of a cylindrical part were simulated with variations in the feed rate of the roller, direction of roller path and roller types. In comparison with the experimental work published by Xia et al. [5], simulation results were discussed and some defects of the spun parts were observed. Despite considerable efforts made by researchers, there are still very few publications which consider the modelling of metal spinning processes, which hampers the application of useful research results to solve industrial problems of new spun parts. This paper reports the development of Finite Element simulation models of a conventional metal spinning process. Using Finite Element explicit formulations, the simulation of the forming of a cylindrical spun part by the single-pass of a roller was conducted. With the intention of understanding the effect of process parameters on the formed part and material deformation mechanisms; leading to the identification of defects in the spun parts and to the development of effective simulation techniques for metal spinning modelling.

## 2. CONVENTIONAL SPINNING

Conventional metal spinning involves localised bending of a sheet metal blank through a series of sweeping strokes to produce a desired shape with a reduction in diameter of the blank over the whole length or in defined areas without the change of the original blank thickness. The incremental passes of the forming tool induce compressive tangential (hoop) stresses in the flange region. Shown in Figure 1 [11], as the roller moves towards the edge of the blank, radial tensile stresses are generated, which produce a flow of material in the direction along the mandrel causing thinning. However this is compensated for by the thickening effect of the tangential compressive stresses. As the roller traverses in the reverse direction, towards the centre of rotation, a build up of material occurs in front of the roller. The resulting tangential and radial compressive stresses generate a displacement of material towards the mandrel [11].

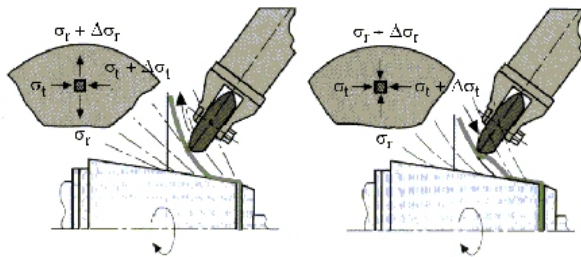

Figure 1. Stresses during conventional spinning [11].

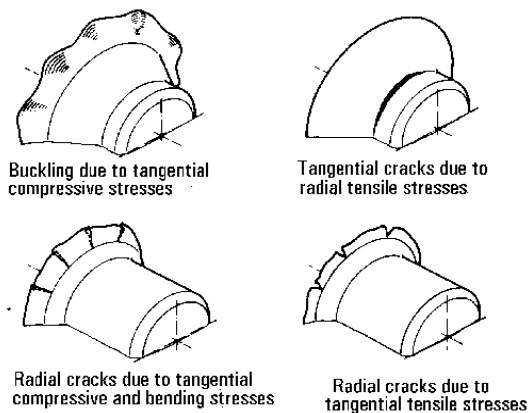

Figure 2. Typical cases of metal failure in spinning [11].

In conventional spinning, defects occur when the radial tensile and tangential compressive stresses are not induced in the appropriate combination progressively through the material. Excessively high stress levels in either direction result in the formation of tangential or radial cracks or wrinkles, a form of buckling as shown in Figure 2. It has been suggested [1] that multiple tool passes are required to shape the blank to the profile of the mandrel without defects. Kobayashi [12] also reported that for a fixed initial blank radius, an increase in the thickness of the blank must be accompanied by an increase in the mandrel radius to prevent wrinkling. The tendency to buckle can also be reduced by increasing the blank support pressure or employing other methods which stiffen and reinforce the edge of the blank [11].

## 3. CONSIDERATIONS IN SIMULATION OF METAL SPINNING

Three types of non-linearity in deformation analyses and simulations are exhibited in metal spinning process, namely, material non-linearity, boundary non-linearity and geometric non-linearity. The material non-linearity is attributed to the material elastic-plastic behaviour and the effects of strain-rate and temperature dependences. Boundary non-linearity is intrinsic to metal spinning because of the complex and changing contacts and interactions between many independent bodies. When the workpiece deforms incrementally over the mandrel under the load applied by the roller, it leads to discontinuous effects resulting from the changing contact conditions and frictional forces. Geometric non-linearity is present in spinning because of the magnitude of the displacements resulting from the plastic deformation and possible post buckling of the spun metal, which affects the response of the structure. In addition, representative metal spinning geometries generally require three-dimensional modelling of very large models and consequently a long computing time. Because the simulation size is large and the nonlinearity dominates in metal

spinning modelling, the explicit dynamics Finite Element analysis approach is more feasible and less expensive computationally than the implicit quasi-static approach.

### 3.1 Explicit dynamics FE procedure

In this research, the commercial Finite Element analysis software ABAQUS is used. ABAQUS/Explicit uses a central difference method to integrate the equations of motion explicitly through time, using the kinematic conditions at one increment to calculate the kinematic conditions at the next increment [13]. At the beginning of the time increment ( $t$ ), the nodal accelerations,  $\ddot{\mathbf{u}}$ , are calculated based on dynamic equilibrium as given in Equation (1):

$$\ddot{\mathbf{u}}|_{(t)} = (\mathbf{M})^{-1}(\mathbf{P} - \mathbf{I})|_{(t)} \quad (1)$$

where  $\mathbf{M}$  is the nodal mass matrix,  $\mathbf{P}$  is the vector of the external applied forces, and  $\mathbf{I}$  is the vector of internal element forces. Since the explicit procedure always uses a diagonal mass matrix, computing for the accelerations is trivial and there are no simultaneous equations to solve. The acceleration of any node is determined completely by its mass and the net force acting on it, making the nodal calculations very inexpensive. Knowing the accelerations, the velocities and displacements are advanced “explicitly” through each time increment  $\Delta t$ , as shown in Equations (2) and (3) [13]:

$$\dot{\mathbf{u}}|_{(t+\Delta t/2)} = \dot{\mathbf{u}}|_{(t-\Delta t/2)} + \frac{(\Delta t|_{(t+\Delta t)} + \Delta t|_{(t)})}{2} \ddot{\mathbf{u}}|_{(t)} \quad (2)$$

$$\mathbf{u}|_{(t+\Delta t)} = \mathbf{u}|_{(t)} + \Delta t|_{(t+\Delta t)} \dot{\mathbf{u}}|_{(t+\Delta t/2)} \quad (3)$$

### 3.2 Simulation speed up techniques

Unlike the implicit FE analysis procedure, the explicit method is conditionally stable. For the method to produce accurate results, the time increments must be quite small so that the accelerations are nearly constant during an increment. Since the time increments must be small, analyses typically require many thousands of increments. The maximum time increment possible is dic-

tated by the stability limit. A simple, efficient but conservative method to estimate the stability limit is to use the element length,  $L^e$ , and the wave speed of the material,  $C_d$  [13]:

$$\Delta t = \frac{L^e}{C_d} \leq \min \left( L^e \sqrt{\frac{\rho}{\lambda + 2\mu}} \right) \quad (4)$$

where the minimum is taken over all elements in the mesh,  $L^e$  is a characteristic length associated with an element,  $\rho$  is the density,  $\lambda$  and  $\mu$  are the Lamé’s constants for the material in the element. The time required for the simulation is directly proportional to the number of time increments required,  $n = T/\Delta t$ , if  $\Delta t$  remains constant, where  $T$  is the actual time period of the event being simulated. Thus, the number of time increments required can be obtained by [13]:

$$n = T \max \left( \frac{1}{L^e} \sqrt{\frac{\lambda + 2\mu}{\rho}} \right) \quad (5)$$

In order to simulate metal spinning processes effectively, it is important to explore the techniques which speed up the simulations. One way to reduce  $n$  is to artificially reduce the time period of the event,  $T$ , or equivalently, increase the linear velocity of the roller in proportion to the increase of the rotational velocity of the mandrel to keep the feed ratio unchanged, called “load rate scaling”. However, this may cause two possible errors. If the simulation speed is increased too much, the inertia forces may become too large and will change the predicted response. Errors may also result from the material behaviour, for example, if the material is strain-rate dependent. Another way to reduce  $n$  is to use “mass scaling”, which artificially increases the material density,  $\rho$ , by a factor of  $f^2$  and reduces  $n$  to  $n/f$ , just the same as decreasing  $T$  to  $T/f$  [13]. This technique leaves the event time  $T$  fixed, thus allowing the treatment of strain-rate dependent material and other behaviours while having exactly the same effect

on inertia forces as speeding up the time of simulation. Similar to load rate scaling, mass scaling factor must not be set too large to allow the inertia forces to dominate and, thus, to significantly change the solution.

#### 4. FINITE ELEMENT SIMULATION MODELS OF METAL SPINNING

In FE simulation, an aluminium sheet blank of an original diameter of 192 mm with thickness of 3 mm is spun into a cylindrical part with an internal nominal diameter of 118 mm by the conventional spinning process using a single roller pass. The geometries and dimensions of the mandrel, clamping holder and roller are taken from the published papers by Liu [10] and Xia et al. [5].

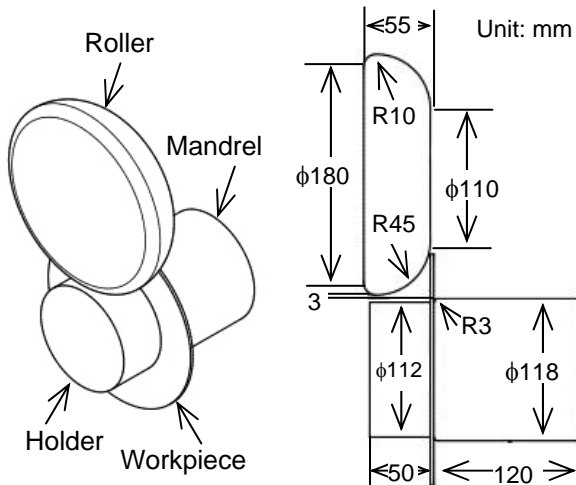

Figure 3. Geometry of FE analysis models.

Table 1. Meshing of Finite Element models.

	Element type	No. of elements
Model 1	Tetrahedral, solid	8727
Model 2	Tetrahedral, solid	8727
Model 3	Hexahedral, solid	3950
Model 4	Quadrilateral, shell	1989

Three-dimensional FE analysis models containing the workpiece and the tools as shown in Figure 3 are developed. The workpiece is modelled using both 3D solid and 2D shell elements with first order interpolation. To achieve effective simulation, different mesh densities are used. The details of four FE models are given in Table

1. The mandrel, holder and roller are modelled using analytical rigid bodies. The principal advantage of representing these parts as rigid bodies instead of deformable bodies is the computational efficiency. The analytical rigid bodies of the tools have smooth surfaces, therefore their contact interactions with the meshed deformable bodies tend to be less noisy than discrete rigid bodies. Coulomb friction is assumed between the workpiece and the mandrel, holder, and roller, with frictional coefficients of 0.2, 0.5 and 0.05, respectively. The lower frictional coefficient between the workpiece and the roller is used to represent the kinetic friction between the two bodies. The isotropic hardening yield curve of pure aluminium (A1100-O) is taken from Kalpakjian and Schmid [14]. Isotropic elasticity is assumed, with Young's modulus of 70 GPa, Poisson's ratio of 0.3 and mass density of  $2700 \text{ kg/m}^3$ . The strain hardening is described using individual points on the flow stress versus plastic strain curve, with an initial yield stress of 100 MPa and a maximum flow stress of 207 MPa. No rate dependence or temperature dependence is taken into account in the simulation.

Table 2. Parameters and scaling factors.

	Roller velocity m/s	Feed rate mm/rev	Simulation speed up technique and factor
Model 1	0.05	15	Mass scaling $\times 5$
Model 2	0.25	15	Load rate scaling $\times 5$
Model 3	0.07	1	Load rate scaling $\times 21$
Model 4	0.21	3	Load rate scaling $\times 21$

Three steps have been specified in all FE models to carry out the metal spinning simulation, namely, "Apply Holder Load", "Initiate Rotation" and "Deform Workpiece". The first step involves the application of the holder force to secure the workpiece between the holder and the mandrel. In the "Initiate Rotation" step the holder, mandrel and workpiece attain the required working rotational velocity. And finally in the "Deform Workpiece" step boundary conditions are specified to define the roller path and linear velocity, and the simulation

proceeds until the metal spun part is fully formed around the mandrel. The nominal process parameters are the same as given in the papers by Liu [10] and Xia et al. [5], with the rotational velocity of mandrel, holder and workpiece of 200 rpm and the roller feed rate of 1 mm/rev. Both the load rate scaling and mass scaling are used to speed up simulations and to compare the modelling responses. Details of the main process parameters and scaling factors of the FE models are given in Table 2.

## 5. RESULTS AND DISCUSSIONS

### 5.1 FE meshing and scaling techniques

The simulations were performed using an Intel® Xeon™ computer of CPU 2.80GHz. Table 3 lists computing times and average stable increments for different FE models. Models 1 and 2 were primarily run to investigate the effects of ‘mass scaling’ and ‘load rate scaling’, respectively. In each model the simulation speed up was configured so that the inertial effects would be identical. As shown in Table 3, the CPU time for Model 2 was significantly lower than that of Model 1. This suggests that speed up by load rate scaling is more efficient for the simulation of metal spinning. Changes to loading rate has been discussed by a number of authors (Wong, Dean & Lin [1] and Hagan & Jeswiet [15]), who have suggested that loading rates can be changed without significant effect on the quality of the product, as long as the loading ratios remain constant. In this research, the material strain-rate dependence is ignored otherwise the mass scaling would provide a better solution in speed up simulations.

Values of the maximum equivalent plastic strains are similar for Models 1 and 2 with values of 2.27 and 2.43, respectively, while the results obtained from Models 3 and 4 give the max values of 3.59 and 3.25, respectively. This may be attributed to the element types and mesh density used in Models 1 and 2, which may underestimate stresses and strains in areas of high stress gradients. Finer meshes would naturally overcome such problems, but such refine-

ment may be unfeasible because of higher computational costs. As shown in Figures 4 and 5, the strain distributions obtained by Models 1 and 2 are quite unrefined because of the severe loading regime imposed, as the feed rate is fifteen times larger than experimental work by Xia et al. [5].

Table 3. Computing times for FE models.

	Modelled time, sec	CPU time hour:min:sec	Avg. stable increment
Model 1	1.4211	21:24:06	6.570E-07
Model 2	0.4011	13:18:59	2.067E-07
Model 3	1.4511	15:27:23	2.707E-07
Model 4	0.4844	10:37:59	2.424E-07

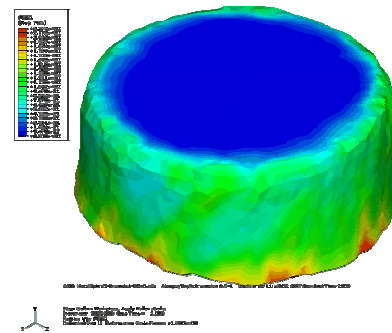

Figure 4. Equivalent plastic strain of Model 1 using mass scaling.

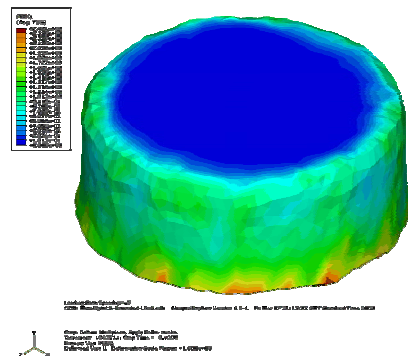

Figure 5. Equivalent plastic strain of Model 2 using load rate scaling.

### 5.2 Plastic strains and thickness changes

The improved hexahedral elements employed in Model 3 allow a more critical comparison with published work. Here process parameters replicated those used by Xia et al. [5]. Load rate scaling was employed to speed up simulation times, kinetic and internal energies of the workpiece were checked to ensure the control of effects of the inertia forces. The kinetic energy calcu-

lated is typically 1%-2% of the internal energy, therefore well within the 5%-10% upper bound which has been suggested not to be exceeded to yield reliable results.

Figure 6 shows an improvement in presenting more refined distributions of plastic strain but the deformed part still exhibits a non-uniform flange deformation, as can be seen from the irregular/ragged edge at the part opening (Figure 7). The factors which cause the irregularity are complex and not well understood, but it appears that the flange irregularity is an early manifestation of buckling/wrinkling effects that result from excessive radial tensile loading. These effects are exaggerated by high feed rates, which essentially mean less material passes under the roller for a given axial movement of the tool.

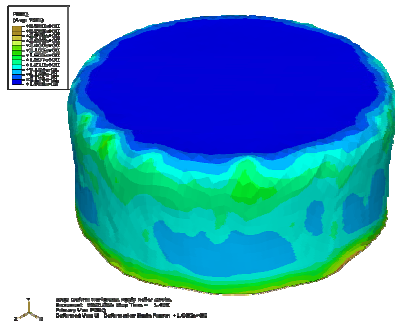

Figure 6. Equivalent plastic strain of Model 3 using feed rate = 1 mm/rev.

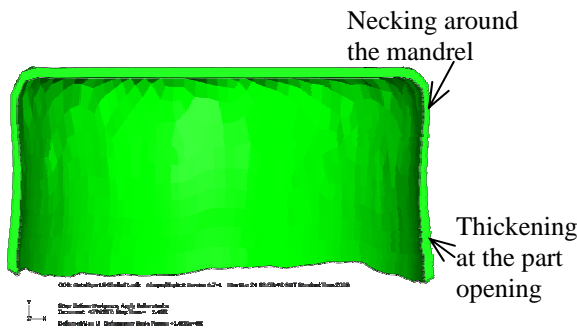

Figure 7. Changes of wall thickness in a section through fully deformed workpiece

Axial sections of the formed part as shown in Figure 7 readily show a variation in wall thickness of the spun part. Confirming that this single pass process is not solely a conventional spinning process as has been suggested by Quigley & Monaghan [3] and Liu [10], but to some extent shear spinning occurs. This agrees with the assertion made

by Wong, Dean & Lin [1] that a single pass process cannot be exclusively regarded as a conventional spinning process.

The change and distribution of thickness obtained by the simulation agree well with experimental results [5]. As illustrated in Figure 7, necking occurs as the workpiece rounds the mandrel edge, as has been suggested by Xia et al. [5]. This thinning is caused by the axial forces which are generated as the roller completes its pass over the depth of the part, similar to the forces which cause necking in deep drawing. Experimental work [5] has also suggested the presence of thickening towards the part opening; this characteristic is exhibited in Figure 7. It seems this is due to the radial and tangential stresses which result from the roller passing along the workpiece flange in an axial direction along the mandrel and the axial build up of material in front of the roller alluded to by Hagan & Jeswiet [15].

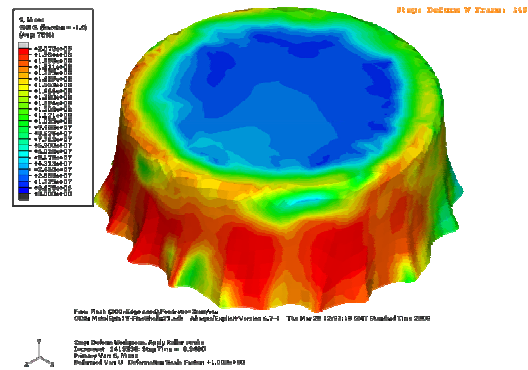

Figure 8. Von Mises stress upon partially deformed workpieces of Model 4, showing evidence of wrinkling at flange edge.

### 5.3 Wrinkling deformation

When compared with Model 3, Model 4 makes use of continuum shell elements and the feed rate is increased by three times, as per work by Liu [10]. As shown in Figure 8, Model 4 exhibits wrinkling deformation at the part opening. Here the Von Mises stress contours show the high stresses present in the wrinkle zone, which can lead to cracking and failure. These same effects were witnessed by Liu [10]. It seems that this wrinkling results from the higher feed rate, which induces a rapid increase in

strain energy in the work zone. However, it is the opinion of the authors that the severity of this wrinkling effect may be exaggerated by the use of shell elements. It seems that the use of shell elements predisposes the model to an increased tangential instability, when compared with solid element models. The validity of this opinion has yet to be tested rigorously; it may therefore be a worthy object of further study.

## 6. CONCLUSIONS

Based on the above results and discussions, the following conclusions can be drawn:

(1) Both 'mass scaling' and 'load rate scaling' speed-up techniques have been employed, which demonstrate a considerable reduction of simulation times with acceptable computational accuracy if the scaling factor is well controlled. However if strain-rate dependent material properties are included in the material models, 'load rate scaling' may be unfeasible.

(2) Results obtained show a good agreement with the published experimental work [5]. Significant changes in material thickness are observed, i.e., necking around the filleted mandrel edge and thickening towards the part opening.

(3) Process parameters such as the feed rate of the roller, mandrel roundness are shown to have pronounced effect upon spinning forces, material thickness and extent of spinning defects. Wrinkling defects have been demonstrated at higher feed rates, although these effects may be exaggerated by the use of shell elements.

## LIST OF REFERENCES

1. Wong C.C., Dean T.A., Lin J., "A review of spinning, shear forming and flow forming processes", *International J. Machine Tools & Manufacture*, vol. 43, 2003, pp. 1419-1435.
2. Kang D.C., Gao X.C., Meng X.F., Wang Z.H., "Study on the deformation mode of conventional spinning of plates", *J. Mat. Proc. Techn.*, vol. 91, 1999, pp. 226-230.
3. Quigley E., Monaghan J., "Metal forming: an analysis of spinning processes", *J. Mat. Proc. Techn.*, vol. 103, 2000, pp. 114-119.
4. Kleiner M., Göbel R., Kantz H., Klimmek Ch., Homberg W., "Combined methods for the prediction of dynamic instabilities in sheet metal spinning", *CIRP Ann.*, vol. 51, 2002, pp. 209-214.
5. Xia Q., Shima S., Kotera H., Yasuhuku D., "A study of the one-path deep drawing spinning of cups", *J. Mat. Proc. Techn.*, vol. 159, 2005, pp. 397-400.
6. Long H., "Quantitative evaluation of dimensional errors of formed components", *J. Mat. Proc. Techn.*, vol. 177, 2006, pp. 591-595.
7. Quigley E., Monaghan J., "Enhanced Finite Element models of metal spinning", *J. Mat. Proc. Techn.*, vol. 121, 2002, pp. 43-49.
8. Quigley E., Monaghan J., "The Finite Element modelling of conventional spinning using multi-domain models", *J. Mat. Proc. Techn.*, vol. 124, 2002, pp. 360-365.
9. Alberti N., Fratini L., "Innovative sheet metal forming processes: numerical simulations and experimental tests", *J. Mat. Proc. Techn.*, vol. 150, 2004, pp. 2-9.
10. Liu C.H., "The simulation of the multi-pass and die-less spinning process", *J. Mat. Proc. Techn.*, vol. 192-193, 2007, pp. 518-524.
11. Leico GmbH & Co., "Spinning and Shear Forming". *Werkzeugmaschinenbau*, 5229 Ahlen/Wesff.
12. Kobayashi, S., "Instability in the conventional spinning of cones", *J. Eng. Ind.*, vol. 85, 1962, pp. 44-48.
13. "ABAQUS Analysis User's Manuals", ABAQUS, Inc., Ver. 6.7., USA, 2007.
14. Kalpakjian, S., Schmid, S., "Manufacturing Engineering and Technology", Prentice Hall Intern., London, 2001.
15. Hagan, E., Jeswiet, J., "A review of conventional and modern single-point sheet metal forming methods", *Proc. Instit. Mechanical Eng., Part B: J. Eng. Manuf.*, vol. 217, 2003, pp. 213-225.