

Middle Bronze Age pottery from Tell el-Burak, Lebanon

Kamal Badreshany* and Jens Kamlah**

Abstract

The excavation of a monumental mud-brick building and revetment wall dating to the Middle Bronze Age at Tell el-Burak have yielded a large assemblage of ceramics. This article gives a summary of the Middle Bronze Age ceramic types found at Tell el-Burak through the 2010 season of excavations and associates them with new carbon 14 evidence to provide an understanding of their chronological, functional, and regional context.

Keywords Tell el-Burak, Middle Bronze Age, pottery, Lebanon

Introduction

Located 9 km south of the city of Saida in southern Lebanon, Tell el-Burak has been the focus of eight excavation seasons (2001–2003, 2005, and 2008–2011) that have uncovered three main settlement phases dating to the Mamluk/Ottoman period and the Iron and Middle Bronze Ages.¹ In Area I, a Mamluk/Ottoman period structure was found overlaying a monumental mud-brick building from the Middle Bronze Age (Figure 1). Area II yielded a massive revetment wall that was built during the Middle Bronze Age. Later, in the Iron Age, a fortification wall was erected on top of this earlier revetment wall. In Area III, buildings dating from the Middle

Iron Age through to the Late Persian period were uncovered.

Tell el-Burak is one of the few known coastal sites in Lebanon that is in a good state of preservation, making it extremely important for the study of Middle Bronze Age ceramics. Area I yielded some 9,000 sherds from the Middle Bronze Age, mostly found in various fill layers of the monumental mud-brick structure. Area II produced about 6,000 sherds from the Middle Bronze Age that were associated with a revetment wall at the foot of the hill, constructed with very large stones. Most of the MBA ceramics from Tell el-Burak, however, were found in an unusual

* Department of Near Eastern Languages and Civilizations, University of Chicago.

** Biblisch-Archäologisches Institut, Eberhard Karls Universität Tübingen.

¹ Cf. the preliminary reports Finkbeiner and Sader 2001; Kamlah and Sader 2003; 2004; 2008; 2010. The Tell el-Burak Project is a joint project of the American University of Beirut (represented by Hélène Sader), the University of Tübingen (represented by Jens Kamlah), and the Oriental Department of the German Archaeological

Institute (represented by Margarete van Ess). We would like to thank all institutions and members of the project as well as the Lebanese Direction Générale des Antiquités for enabling us to work on the Middle Bronze Age pottery of Tell el-Burak. We would especially like to thank Hélène Sader for organizing the workshop on the Middle Bronze Age pottery of Lebanon. This report on the pottery from Tell el-Burak includes a preliminary analysis of material up until the seventh season (2010).

contextual situation. Only very few specimens were uncovered in situ. In fact, most of the ceramics forming the MBA assemblage from Tell el-Burak were found in fill layers that were deposited during the construction of the mud-brick building. It would seem that Tell el-Burak itself was built as an artificial hill during the construction of the mud-brick building. The building measures 41.6 x 35.5 meters and consists of 19 rooms with a central courtyard (Figure 2).² The mud-brick building clearly had a public character, possibly serving as a fortress, palace, or some combination of both.

The lack of material from well-stratified occupation layers makes constructing a detailed typological and chronological sequence impossible at present. Furthermore, only a couple of floor surfaces in the mud-brick building yielded significant amounts of material, allowing only a few opportunities to assess consumption at specific locales within it. Due to the poor contextual situation of the majority of the ceramics from this assemblage, we have focused our efforts on making more generalized conclusions based on the material, both in terms of chronology and in terms of general consumption patterns.

Carbon 14 Dates

Sixteen Middle Bronze Age carbon 14 dates have been established from Tell el-Burak so far (Figure 3).³ They come from various contexts in the mud-brick building (Figure 4). The earliest sample (24) was found on the lowest floor in Room 15 (i.e., the oldest phase of the building). The sample's calibrated date from the end of the third millennium BC can possibly be attributed to the material of the sample (charcoal).⁴ Sample 5

comes from the burial found outside of Room 7. This sample represents the latest Middle Bronze Age date from Tell el-Burak (~1735–1690 calBC), and it fits well with the dating of the pottery from the burial (see below).

The fourteen remaining carbon 14 dates have a range of ca. 2000–1750 calBC. They clearly date the construction of the mud-brick building to the beginning of the Middle Bronze Age and also point to a relatively short period of use.

Chronological Terminology

Currently, great difficulties exist in placing ceramics from the Middle Bronze Age found at sites in southern Lebanon into a rigid chronological framework. A lack of Middle Bronze Age pottery associated with well-established stratigraphic sequences and reliable radiocarbon dates on the southern Lebanese coast forces associations with distant areas to determine absolute dates. In fact, in the whole of southern Lebanon, only neighboring Sidon has produced a significant amount of MBA pottery. Most of the material that has been published, however, was found in tombs (Doumet-Serhal 2004 and 2008) and is difficult to use for establishing a detailed absolute or relative chronology. It would be unwise to assume heterogeneity across the Levant in terms of the absolute dates associated with the emergence, zenith, and decline of specific ceramic types. Therefore, relying on absolute dates based on stylistic comparisons with material from distant areas is problematic. Most of the MBA material from Tell el-Burak shows close parallels with Sidon and sites farther away in northern Palestine. However, there are a few types that represent idiosyncrasies with no clear parallels indicating

² For a detailed description of the Middle Bronze Age mud-brick building, cf. Kamlah and Sader 2010: 93–115.

³ We would like to thank the carbon 14 laboratories at Kiel (Leibniz-Labor für Altersbestimmung und Isotopenforschung; KIA) and at Vienna (Vienna Environmental Research Accelerator; VERA) for participating in the project. The next preliminary report of the Tell el-Burak Project will include a complete list of all carbon 14 dates from the site (to be published in *BAAL*). In this report, Felix Höflmayer together with Eva Maria Wild and other members of the VERA will present preliminary

comments on the carbon 14 dates from the laboratory at Vienna. We would like to thank Simone Riehl (Tübingen) for analyzing the botanical remains as well as Julia Bertsch and Henrike Michelau (Tübingen) for organizing the carbon 14 samples from Tell el-Burak. The presentation of the carbon 14 dates in this report is based on OxCal v4.1.7.

⁴ It has to be stated that another four samples (not included in Figures 3 and 4) yielded results from the 3rd millennium BC and that two of them consisted of charred seeds. They will be discussed in the final publication of the results.

a more dynamic nature to the development of Middle Bronze Age pottery styles. As a result, the absolute chronology used in this study will remain purposefully vague, encompassing both the high and low chronology commonly used in the northern and southern Levant (see Cohen 2002 for an excellent overview of the history of MBA chronology). When better sequences from southern Lebanon are produced, our chronology will be reevaluated. In the interim, the radiocarbon dates mentioned above can be used cautiously as an indicator of the absolute dates associated with the MBA ceramics from Tell el-Burak.

The relative chronology associated with ceramics from southern Lebanon is also contentious as was evident from the workshop. There seems to be a consensus among scholars working in Lebanon against the use of the older tripartite system formerly employed for the Middle Bronze Age in Palestine (MB IIA, MB IIB, and MB IIC). Genz (et al 2011: 190), Doumet-Serhal (2004: 90), and Thalmann (2006: 135–136) have all used variants of the Syrian chronology or updated versions of Palestinian chronology (see Ilan 1995: 297–300). MB I is used in place of MB IIA, MB II in place of MB IIB, and MB III in place of MB IIC. We will use a two level division here, following the practice of Genz and Thalmann, because forms dating to the MB III, as it is sometimes referred to in Palestine, have not materialized yet in Lebanon in great numbers. We will provide the absolute dates associated with both the low and very low chronology (Figure 5) to help orientate the reader; however, as discussed above, the absolute dates are subject to change.

Typology

The close relationship between the Middle Bronze Age ceramic material from Tell el-Burak and that found in northern Palestine is evident from our list of parallels, which rarely looks towards the north for forms. Strong parallels have also been found with the material from Sidon. Six major categories of types have been noted and will be presented in order of their prevalence. These are: jars (Type 1), cooking pots (Type 2), shallow bowls (Type 3), deep bowls (Type 4), jugs (Type 5), and juglets (Type 6).

Figure 6 shows that nondescript handles (Figure 26) and bases (Figure 25) make up the large majority of the diagnostic sherds. Of the distinguishable types, jars — for example so-called Caananite jars and larger pithoi — are the most common. Also, it should be noted that the majority of bases and many of the handles probably belong to jars, certain to increase their relative abundance in the assemblage after further analysis.

Most of the types in the study material can be dated with a great degree of certainty to the MB I, with some types belonging to the MB I/II transition or the early part of the MB II. Narrowing this chronology any further proved difficult, as many of the types found at Tell el-Burak remained in vogue for the entire Middle Bronze Age and in some cases the Late Bronze Age. Nonetheless, much of the available evidence points to a date in the MB I for the construction of the mud-brick building.

Jars

Large jars primarily intended for the storage, transportation, and trade of commodities like wine, grain, olive oil, and a plethora of other goods were the most common identifiable type found at Tell el-Burak. The sizes differ from small (approx. 50 cm) to large (approx. 1 m). The Middle Bronze Age assemblage from Tell el-Burak mainly yielded bases, rims, and handles.

Jars are the most numerous datable type found at Tell el-Burak in both the Iron and the Middle Bronze Age. Unfortunately, many of these types are long-lived during the Middle Bronze Age and not extremely useful for chronological purposes.

Type 1A: Storage Jar with High Neck and Everted Rim

Three subtypes were identified within this group. Type 1Aa (Figures 8.1, 8.2, and 8.5) is the most common storage jar type. It has a simple rounded rim that is everted. 37 sherds were found. Type 1Ab (Figure 8.3) has a similar rounded, everted rim to Type 1Aa, but tends to be shorter and has a small ridge. Type 1Ac (Figure 8.4) has a short neck with a more squared and sharply everted rim.

Type 1B: Storage Jars with Pendant⁵ Rim

Three subtypes were identified within this group. Type 1Ba (Figure 8.6) has an everted, thick pendant rim. Type 1Bb (Figure 8.7) has an everted pendant rim that is ridged. 2 pieces were found in Area I. Type 1Bc (Figures 8.8 to 8.12) has a thick and pronounced pendant rim that is squared off. There is slight variation within this group as some of the pieces are undercut, but since the exteriors of the rims are similar they are classed under the same type. This type was found in both areas with 23 sherds uncovered.

Type 1C: Storage Jar with Flattened and Stepped Rim

One example of this stepped rim, dated to the MBA IIB at Shechem (Cole 1984: 171) and corresponding to our MB I/II transition, was found in Area II (Figure 8.13). This rim is flat, rounded, and short with its step near the center.

Type 1D: Storage Jar with Flattened Rim

Two storage jars with circular and flattened rims were found in Area I (Figures 8.14 and 8.15). They are similar to each other except that 15 has a slightly thinner and more rounded rim.

Type 1E: Storage Jar with In-turned Circular Rim

One example of Type 6E (Figure 8.16) was found in Area I. This type has an in-turned rim that forms an interior and exterior overhang.

Type 1F: Storage Jar with In-turned Triangular Rim

Two examples of Type 1F (Figures 8.17 and 8.18) were found in Area I. This type has an in-turned rim with parallels on small vessels of the early MB IIA at Aphek, which corresponds to our early MB I (Kochavi and Yadin 2002: 205 figure 18-4).

Ridged-Neck Pithoi

One of the few vessel types found in situ at Tell el-Burak is what has been termed by Stager (2002: 358; fig. 17 and 18) the “Ridged-Neck Pithoi”. A

large number (at least 10 separate vessels) were found in Room 13 of the mud-brick building. This vessel is a type of storage jar, but we have separated it here due to its idiosyncratic nature and the variety of sub-types. This form, according to Stager, has no parallels in the Levant (2002: 357), and he claims he has only ever seen the type in Egypt at Tell el-Dab’a stratum G/1-3. We also have not been able to find a satisfactory parallel for these types or anything resembling them, with the exception of the parallels from Ashkelon and Tell el-Dab’a noted above. Interestingly, a petrographic analysis conducted on these types found at Ashkelon places their origin on the Lebanese coast (Stager 2002: 357 and Stager et al 2008: 231). A preliminary investigation of the ware does not show anything inconsistent with the local ware groups, however more work needs to be done to verify this. A petrographic analysis will be conducted on these samples in the near future to verify their provenience and similarity to the Ashkelon and Tell el-Dab’a specimens. These types occurred in Phases 14 and 13 at Ashkelon and in stratum G/1–3 at Tell el-Dab’a, which are both dated to 1850–1725 BC by the archaeologists (Stager et al 2008: 231; see p 217 for chronology chart).

Four categories have been noted. Type 2A (Figures 9.1 and 9.7) with the rim folded over is the most common. Type 2B (Figures 9.2, 9.3, 9.4, 9.5, 9.8, 9.9, 9.10, 9.11, 9.12, and 9.13) with the rim rolled is the second most common. Two examples were found with an in-turned triangular rim (Figures 9.5 and 9.6) and one example was found that could have been a vat (Figure 9.14).

Examples from all of the different types were found on the same surface, indicating that these different forms were in fashion contemporaneously. The ware of the Ridged-Neck Pithoi is usually very coarse and poorly fired. These vessels sometimes appear decorated with paint on the rim as in Figure 9.4, and some body sherds were found painted with black bands.

⁵This terminology was taken from Anderson (1988: 456), for lack of a better term to describe these rim styles.

Interestingly, these ridged-neck vessels were sometimes found with a whitish material coating their interiors (Figure 10). An analysis of this material has shown that it is lime plaster very similar in composition to the plaster found in the rooms of the mud-brick building. Several of the rooms in the mud-brick building are covered with white plaster. It would seem that in this context the Ridged-Neck Pithoi were being used to store and possibly mix (given the possible occurrence of a vat) plaster for use on the walls and floor of the mud-brick building. Certainly, these jars could have been used for a wide variety of contents and applications, and it may indicate that the last activity to take place in Room 13 was the storage of plaster, that either the building was undergoing a period of maintenance during the last phase of its use or that the building was abandoned before it was completely finished.

Cooking Pots

Cooking pot fragments were quite common within this assemblage. They are easily discernable as they are composed of a very distinct ware, which is coarse and poorly fired. The overwhelming majority of cooking pot types at Tell el-Burak are of the gutter rim variety. These forms are common in Palestine during the MB I and strong parallels can be found at many sites including Aphek (Kochavi and Yadin 2002: 213) and Megiddo (Ilan et al 2000: 195). At Tell el-Burak, the length of the rim and its curvature vary greatly, as shown on Figure 13. All have a globular shape. In a couple of cases a chevron pattern of incisions was found on the shoulder (Figure 11).

Type 2A: Gutter Rim Cooking Pot

The vast majority of diagnostic cooking pot sherds were of the hole-mouth cauldron variety with a gutter rim, or Type 2A (Figures 13.1–13.7, 13.9, and 13.10). This type has a rim everted at a 60-degree angle that is slightly curved near the center.

Type 2B: Folded Rim Krater

A couple of examples of folded rim kraters were found at Tell el-Burak (Figure 13.8). Parallels are common during the MB I from southern Lebanon

at Sidon (Doumet-Serhal 2003: 200 Plate 13-2) and in northern Palestine at a number of sites including Aphek (Kochavi and Yadin 2002: 213 figure 23: 4–8).

One example of a complete folded rim krater (Figures 14 and 15) was found under the original floor of Room 11. Based on the associated stratigraphy, there is strong evidence that it was placed there very carefully and immediately covered with a reddish fill. It is unclear why this was done. One suggestion is that the pot may have been part of some ritual related to the foundations or construction work on the building. An organic residue was also noted in the vessel and is currently being analyzed.

This spouted folded rim krater is composed of the cooking ware typical at Tell el-Burak during the MBA. Other spouted examples probably exist in the assemblage from Tell el-Burak, but the pottery is so fragmented that positive identifications have been elusive. Parallels have been found in Palestine (Tell Aphek: Kochavi and Yadin 2002: 213, fig. 23–4; 'Ain Zurekiyeh: Gophna and Ayalon 1982: 74 fig. 7-3). All of these were dated to the MB I. A close parallel that dates to the MB I can be found in a burial at Sidon (Doumet-Serhal 2008: 27; fig. 19-s/1805). No other examples were found in later burials at Sidon.

Shallow Bowls

The sherds of bowls within this assemblage, while numerous, are extremely fragmented. Rims are rare, allowing us to identify only 4 different types so far. Bowl bases, represented by two types, are far more common.

Type 3A: Hemispherical Bowl

At Tell el-Burak hemispherical bowls were the most common type of bowl, with 40 specimens found in total. They can be divided into three subcategories: 3Aa, 3Ab, and 3Ac. Type 3Aa has a simple rounded rim (Figure 17.1) and was represented by 31 sherds. Type 3Ab differs as the rim has either a slight (Figure 17.3) or strong incurve (Figure 17.2). The rim with the slight incurve was represented by 5 sherds. The

rim with the strong incurve was represented by 3. Unfortunately, hemispherical bowls are too common to provide any narrower chronological assessment other than identification as Middle Bronze Age.

Type 3B: In-turned Triangular Rim Bowl

The bowls with the in-turned triangular rim were also common (Figures 17.4 and 17.5), with 19 sherds identified. The rims varied only slightly with respect to the degree of the in-turn, with nearly all exhibiting an in-turn of between 50 or 60 degrees. One specimen had an extreme incurve of about 30 degrees. As with the hemispherical bowls, these types are far too common to provide a closer date other than Middle Bronze Age.

Type 3C: Circular Rim Ridged Bowl

A type of bowl with a slight ridge under a circular rim (Figure 17.6) was far less represented at Tell el-Burak, with only two pieces found. Again, this type is too common during the MBA to help narrow our chronology.

Type 3D: Carinated Shallow Bowl

Carinated shallow bowls were also found in this assemblage. Type 3D has a carination of medium sharpness with an everted rim (Figure 17.7). These types of bowls are more useful for closer chronological assessment. Based on the degree and position of their carination, which tends to become lower later in the MBA (Nigro 2002: 103), the carinated bowls found at Tell el-Burak more likely belong to the MBA I than the MB II in Syria. In addition, this slight but flaring carination is more typical of the early Middle Bronze Age II (our MB I) at Megiddo (Ilan et al 2000: 194).

Deep Bowls

Our definition of a deep bowl is a wide-mouthed vessel with a depth generally equal to or greater than the maximum diameter of the mouth. Here we will amend the definition to say slightly greater than the maximum diameter of the mouth instead of greater. This subjective terminology separates deep bowls from jars, storage jars, jugs, and pithoi. However, with more subject material,

especially complete vessels, one could define this quantitatively.

The deep bowl has been well studied allowing for a somewhat more precise chronology. It is more or less possible to classify this type by the degree and position of its carination (Nigro 2002: 103). Vase-like bowls that are sometimes referred to as “S-profile” or “necked” are also common in the MBA I. These are similar to the carinated bowls but have duller rounded curves and smaller rims.

Type 4A: Necked Bowl

At Tell el-Burak the most chronologically useful bowls are the necked forms (Figures 19.1 and 19.3). 5 of those found were of a type with a slightly curved neck and flattened rim. While they appear in Area II, not one was found in Area I. These types do not appear in Palestine until the very end of the MB I or the beginning of the MB II depending on the site (Kochavi and Yadin 2002: 218; Cole 1984: 54; Kopetzky 2008: 217). These forms will be considered to belong to the MB I/II transition or the beginning of the MB II at Tell el-Burak until more evidence from southern Lebanon can provide a better understanding of their earliest appearance.

Type 4B: Carinated Deep Bowl

Type 4B is less distinct chronologically than Type 4A. It can be divided into 5 subgroups. Type 4Ba (Figures 19.2, 19.4, 19.5, and 19.6) has a sharply everted, nearly flattened rim, and is represented by 13 examples. Type 4Bb (Figures 19.7, 19.8, 19.9, 19.10, 19.13, and 19.14) has a slightly everted rim and is represented by 22 sherds that can be found throughout the MBA (Ilan et al 2000: 194). Type 4Bc, one of the “Gublite” bowls, was found in Area I (Figure 19.11). This type has a sharply everted rim and a sharp carination midway down the body. This type is more common earlier in the MBA (Nigro 2002: 103; Akkermans and Schwartz 2003: 293). Type 4Bd has a slightly more flaring carination (Figure 19.12). Type 4Be (Figure 19.15) is a globular bowl with a slight carination and a flattened rim, of which one example is attested.

Jugs

The Jug typology at present is limited; however more examples were found in the 2010 season and will be integrated into the typology in the near future.

Type 5A: Jug with High Everted Rim

Type 5A (Figure 21.1) was common with 11 fragments found. This type has a high slender neck with a slightly flaring rim.

Type 5B: Jug with Gutter Rim

This type (Figure 21.2) has a rounded rim, with a rounded ledge cusped toward the middle. One example found in Area II was the only jug rim from that area. There may have been more, but it is difficult to differentiate between jar and jug rims and between bowl and jug bases, as they come in similar varieties. Type 5B is a general indicator of the MBA I (IIA) at Megiddo (Ilan et al 2000: 201).

Type 5C: Jug with Thin Flattened Rim

Type 5C (Figure 21.3) has a very thin flattened and cusped rim. 2 sherds of this form were found.

Type 5D: Jug with Rounded In-turned Rim

6 fragments of Type 5D (Figure 21.4) occurred in the assemblage. This type has a short, cusped rim that is in-turned with rounded edges.

Juglets

While juglets are among the least common distinguishable type at Tell el-Burak, they come in a large variety. Good examples of the typical MBA piriform juglet (Figure 22) were uncovered in several contexts.

Type 6A: Piriform Juglet

Complete piriform juglets were found in the burial and in other contexts. They usually have a sharply everted rim, a double handle, and a flat or button base (Figures 24.1, 24.2, 24.3, and 24.4).

Type 6B Flat Bottom Juglet Base

8 pieces of flat bottom juglet bases (Figure 24.7 and 24.9) were found. These types have a smooth bottom and a very thick base. Flat and button bases were more common than rims.

Type 6C Button Base Juglets

Examples of button base juglets (Figures 24.5, 24.6, and 24.8) were found. They exhibit a protruding button rounded at the center of a thin base.

Decorative Elements

Red slip is the single most frequent surface decoration used during the Middle Bronze Age at Tell el-Burak (Figure 27). Slipped sherds are often found exhibiting both horizontal and vertical burnishing.

Painting is rare but attested, occurring in both bichrome and monochrome styles. Painting can occur directly on the fabric or over a slip. The so-called “Levantine Painted Ware”, typical of the Middle Bronze Age occurs most frequently (Figure 28). This pattern is found occasionally on body sherds likely to belong to large jars, and on smaller sherds that are indistinguishable.

Combing, in the form of parallel horizontal lines and tick mark incisions (Figure 29), was observed and is typical of the MBA in this region (Amiran 1967: 80). A very common decoration for the period, diagonal incisions, was observed on a number of pieces in the assemblage.

Tell el-Yahudiyeh Vessels

Two nearly complete examples of Tell el-Yahudiyeh wares were found, one associated with a burial and another in an unstratified context that could have been near a disturbed burial. These specimens represent the most singular ceramic finds from Tell el-Burak so far, being unique both in terms of their form and their ware.

The first vessel (Figures 30 and 31) came from a burial and was found amongst a complex of pottery. A comparative analysis of the rest of the burial assemblage places the material in either the MB I/II transition or the earlier MB II depending on the relative chronology being utilized (Kamel 2005); radiocarbon dates from the burial gave calibrated dates of ca. 1735–1690 BC (see above Figures 3 and 4; R_Date 5). As mentioned earlier it is thought that the burials date to the latest phase of occupation during the Middle Bronze

Age, or even postdate the major period of use for the building. The material associated with the burials is thought to be later than other contexts associated with the mud-brick building.

The vessel is composed of a ware typical for Tell el-Yahudiyeh vessels, a fine fabric with few inclusions and a brown surface. The rim of the vessel is reminiscent of the pendant rims typical for large and small jars during this period, but no exact parallel could be found for this vessel.

The second Tell el-Yahudiyeh specimen, a three-footed vessel that defies any real classification, was found in a general context but with some other complete finds (Figure 32). We speculate that the material may come from a disturbed burial, but no trace of the burial was found. The vessel has a very odd shape, and it may actually be a closed form as a piece that exhibits a rosette pattern appears to form part of the shoulder (Figure 33).

The decoration on both vessels is of a similar style featuring bird motifs filled with a white paste as is typical for Tell el-Yahudiyeh vessels. The three-footed vessel differs in that it also exhibits floral motifs including rosettes around the shoulder and what might be lotus flowers on the sides. The bird motif also differs on the two vessels. The type of birds on the first vessel is not a type of waterfowl, but rather a more terrestrial variety. The second vessel seems to have a mixture of terrestrial birds and waterfowl (Figure 34).

While no parallel can be found for the shapes of either of these vessels, good stylistic parallels for the decorative motifs exist on juglets from burials at Tell el-Dab'a (Figure 35). These forms appear at Tell el-Dab'a in phase E/2 and continue to phase E/3, dating to roughly the 17th century BC according to the chronology in use at Tell el-Dab'a. A rosette pattern strikingly similar to that found on the shoulder piece of the three-footed Tell el-Yahudiyeh bowl from Tell el-Burak appears on the shoulders of juglets from Tell el-Dab'a.

Ware Groups

The wares at Tell el-Burak are very difficult to classify due to their heterogeneity, both in terms of clay preparation and firing. This is not the case for the Iron Age ceramics from the site, where one can easily establish a ware classification of six or seven different types with only a few outliers. We are currently in the preliminary stages of a quantitative analysis that will aid us in forming our ware classification for the MBA. Even though many of the Middle Bronze Age sherds defy strict classification, we have been able to confidently identify at least two main ware groups.

Ware A is the most frequently encountered ware in the Middle Bronze Age assemblage and is found on all types. 7.5YR 6/6 reddish yellow is the most common color, although this ware demonstrates a variety of colors from grays to reds. This plethora of shades is the result of differing levels of oxidation due to the incomplete firing characteristic of most of the MBA pottery from Tell el-Burak. This ware often contains numerous large inclusions. A preliminary petrographic analysis indicated the presence of calcareous inclusions (including sparse calcite), sand-sized quartz, and red fragments of shales sometimes called Argillaceous Rock Fragments (ARF's). The clay of ware group A contains small fossils called foraminifera, typical of coastal clays in Lebanon (Griffiths 2006: 288, Badreshany and Genz 2009: 76, and Goren et al 2004: 134–161).

It should be noted that some well-fired specimens that belong to this ware group were found within the MBA assemblage. Most of the sherds that date to the MBA at Tell el-Burak contain moderate cores. Some juglets and the Tell el-Yahudiyeh ware do not exhibit cores.

Ware B is the cooking ware for the Middle Bronze period, as attested by its occurrence on what are commonly considered cooking pot rims. This ware is frequently found in the MBA layers at Tell el-Burak, and usually exhibits a color of 10R

5/6 red. This type has a rough feel and fractures jaggedly. The preliminary petrographic analysis indicated calcareous inclusions and calcite are frequent. Traces of quartz, feldspars, and iron rich minerals are also notable. Foraminifera occur commonly.

Conclusions

Given that the majority of the Middle Bronze Age ceramics found at Tell el-Burak were associated with “fill layers”, building a rigid chronology is impossible at present. Based on comparative examples and the radiocarbon dates from the site, the majority of the assemblage seems to date to the MB I with some examples dating to the MB I/II transition and early MB II.

Bibliography

Akkermans P and Schwartz G 2003 *The Archaeology of Syria: From Complex Hunter-Gatherers to Early Urban Societies (ca. 16,000–300 BC)*. Cambridge: Cambridge University Press.

Amiran R 1969 *Ancient Pottery of the Holy Land*. Jerusalem: Masada Press.

Anderson W P 1988 *A Stratigraphic and Ceramic Analysis of the Late Bronze and Iron Age Strata of Sounding Y at Sarepta (Sarafand, Lebanon)*. Beirut: Publications de l'Université Libanaise.

Aston D and Bietak M 2011 *Tell El-Dab'a VIII: The Classification and Chronology of Tell El-Yahudiya Ware*. Vienna: Österreichischen Akademie der Wissenschaften (hereafter ÖAW).

Badreshany K and Genz H 2009 Pottery production on the northern Lebanese coast during the Early Bronze Age II–III: The petrographic analysis of the ceramics from Tell Fadous-Kfarabida. *BASOR* 355: 51–83.

Cohen S 2002 *Canaanites, Chronologies, and Connections: The Relationship of Middle Bronze Age IIA Canaan to Middle Kingdom Egypt*.

Importantly though, the increasing amount of in situ pottery found in the mud-brick building at Tell el-Burak has the potential to provide a new perspective on pottery consumption during the Middle Bronze Age in Lebanon because it comes from non-domestic contexts. These “public” contexts have already produced unique types in the form of the Ridged-Neck Pithoi and the singular Tell el-Yahudiyeh vessels. Further excavations will surely continue to produce interesting forms from more reliable contexts, allowing for a better understanding of both the chronology of the mud-brick building and the variation in consumption patterns between public and domestic contexts during the Middle Bronze Age in southern Lebanon.

Studies in the Archaeology and History of the Levant 3. Winona Lake, IN: Eisenbrauns.

Cole D P 1984 *Shechem I. The Middle Bronze Age IIB Pottery*. Ann Arbor, MI: ASOR.

Doumet-Serhal C 2003 Fifth season of excavation at Sidon: Preliminary report. *BAAL* 7: 175–207.

Doumet-Serhal C 2004 Sidon (Lebanon): Twenty Middle Bronze Age burials from the 2001 season of excavation. *Levant* 36: 89–154.

Doumet-Serhal C 2008 The British Museum excavation at Sidon: Markers for the chronology of the Early and Middle Bronze Age in Lebanon. In M Bietak and E Czerny (eds) *The Bronze Age in the Lebanon: Studies on the Archaeology and Chronology of Lebanon, Syria and Egypt*. Vienna: ÖAW, 11–44.

Finkbeiner U and Sader H 2001 The Tell el-Burak archaeological project, a preliminary report on the 2001 season. *BAAL* 5: 173–195.

Genz H, el-Zaatari S, Çakırlar C, Badreshany K, and Riehl S 2010 A Middle Bronze Age burial from Tell Fadous-Kfarabida, Lebanon. *Ägypten und Levante* 20 (2010): 183–205.

- Gophna R and Ayalon E 1982 A fortified Middle Bronze Age II A site at 'Ain Zurekiyeh in the Poleg Basin. *Tel Aviv* 9:69–78.
- Goren Y, Finkelstein I, and Na'aman N 2004 *Inscribed in Clay: Provenance Study of the Amarna Tablets and Other Ancient Near Eastern Texts*. Monograph series 23. Tel Aviv: Yass Publications in Archaeology, Institute of Archaeology, Tel Aviv University.
- Griffiths D R 2006 The petrography. In C Doumet-Serhal (ed) *The Early Bronze Age in Sidon: "College Site" excavations (1998–2000–2001)*. *BAH* 178. Beirut: IFPO.
- Ilan D 1995 The Dawn of Internationalism: The Middle Bronze Age. In T E Levy (ed) *The Archaeology of Society in the Holy Land*. London: Leicester University, 297–319.
- Ilan D, Hallote S, and Cline E 2000 The Middle and Late Bronze Age pottery from Area F. In I Finkelstein, D Ussishkin, and B Halpurn (eds) *Megiddo III: The 1992–1996 Seasons*. Tel Aviv: Emery and Claire Yass Publications in Archaeology, 190–215.
- Kamel D 2005 *The Middle Bronze Age Burials of Tell el-Burak*. MA thesis, Department of History and Archaeology, American University of Beirut.
- Kamlah J and Sader H 2003 The Tell el-Burak archaeological project preliminary report on the 2002 and 2003 seasons. *BAAL* 7: 145–173.
- Kamlah J and Sader H 2004 Deutsch-libanesische Ausgrabungen auf Tell el-Burak, Südlich von Sidon. *ZDPV* 120–2: 123–140.
- Kamlah J and Sader H 2008 The Tell el-Burak archaeological project preliminary report on the 2005, 2008 and 2009 seasons. *BAAL* 12: 17–34.
- Kamlah J and Sader H 2010 Deutsch-libanesische Ausgrabungen auf Tell el-Burak, Südlich von Sidon: Vorbericht nach Abschluss der siebten Kampagne 2010. *ZDPV* 126–2: 93–115.
- Kochavi M and Yadin E 2002 Typological analysis of the MB IIA pottery from Aphek according to its stratigraphic provenance. In M Bietak (ed) *The Middle Bronze Age in the Levant: Proceedings of an International Conference on MB IIA Ceramic Material, Vienna, 24–26 January 2001*. ÖAW, Denkschriften der Gesamtkademie, Band 26. Contributions to the Chronology of the Eastern Mediterranean, vol 3. Vienna: ÖAW, 189–227.
- Kopetzky, K 2008 The MB IIB-corpus of the Hyksos period at Tell el Dab'a. In M Bietak and E Czerny (eds) *The Bronze Age in the Lebanon: Studies on the Archaeology and Chronology of Lebanon, Syria, and Egypt*. Vienna: ÖAW, 195–242.
- Nigro L 2002 The Middle Bronze Age pottery horizon of northern inner Syria on the basis of the stratified assemblages of Tell Mardikh and Hama. In M al-Maqdissi, V Matoian, and C Nicolle (eds) *Céramique de l'Âge du Bronze en Syrie I. La Syrie du Sud et la vallée de l'Oronte*. *BAH* 161. Beirut: IFAPO, 97–128.
- Stager L 2002 The MB IIA ceramic sequence at Tel Ashkelon and its implications for the "Port Power" model of trade. In M Bietak (ed) *The Middle Bronze Age in the Levant: Proceedings of an International Conference on MB IIA Ceramic Material, Vienna, 24–26 January 2001*. ÖAW, Denkschriften der Gesamtkademie, Band 26. Contributions to the Chronology of the Eastern Mediterranean, vol 3. Vienna: ÖAW, 353–362.
- Stager L, Schloen D, Master D, Press M, and Aja A 2008 14: North Slope. In L Stager, D Schloen, and D Master (eds) *Ashkelon 1: Introduction and Overview (1985–2006)*. Winona Lake, IN: Eisenbrauns, 220–254.
- Thalmann J P 2006 *Tell Arqa I. Les Niveaux de l'âge du Bronze*. *BAH* 177. Beirut: IFPO.

List of Figures with Captions

- Figure 1. Topographical plan of Tell el-Burak with excavation areas.
- Figure 2. Plan of the monumental mud-brick building at Tell el-Burak.
- Figure 3. Middle Bronze Age radiocarbon dates from Tell el-Burak.
- Figure 4. Material and contexts of the Middle Bronze Age Carbon 14 dates from Tell el-Burak.
- Figure 5. Relative and absolute chronology.
- Figure 6. Categories of types and their relative occurrence in the Middle Bronze Age pottery assemblage of Tell el-Burak.
- Figure 7. Description of jars found on Figure 8.
- Figure 8. Jars.
- Figure 9. Ridged-neck pithoi.
- Figure 10. White plaster covering the inside of a body sherd belonging to a Ridged-Neck Pithos from Room 13.
- Figure 11. Gutter rim cooking pot with chevron pattern.
- Figure 12. Description of cooking pots and kraters found on Figure 13.
- Figure 13. Cooking pots and craters.
- Figure 14. Folded rim krater with spout.
- Figure 15. Folded rim krater with spout in situ.
- Figure 16. Description of shallow bowls found on Figure 17.
- Figure 17. Shallow bowls.
- Figure 18. Description of deep bowls found on Figure 19.
- Figure 19. Deep bowls.
- Figure 20. Description of jugs on Figure 21.
- Figure 21. Jugs.
- Figure 22. Piriform juglet with button base and traces of red slip (Burial Context).
- Figure 23. Description of juglets found on Figure 24.
- Figure 24. Juglets.
- Figure 25. Bases.
- Figure 26. Handles.
- Figure 27. Red slipped and burnished ring base.
- Figure 28. Monochrome painted body sherd (so-called Levantine Painted Ware).
- Figure 29. Decorative Patterns.
- Figure 30. Tell el-Yahudiyeh vessel from a burial outside of Room 7.
- Figure 31. Tell el-Yahudiyeh vessel from a burial outside of Room 7.
- Figure 32. Three-footed Tell el-Yahudiyeh vessel; bottom part.
- Figure 33. Three-footed Tell el-Yahudiyeh vessel; shoulder.
- Figure 34. Three-footed Tell el-Yahudiyeh vessel; detail with head and beak of a waterfowl (?).
- Figure 35. Juglets with birds and flower motifs from Tell el-Dab'a (after Aston and Bietak 2011: 380; Plate 26).

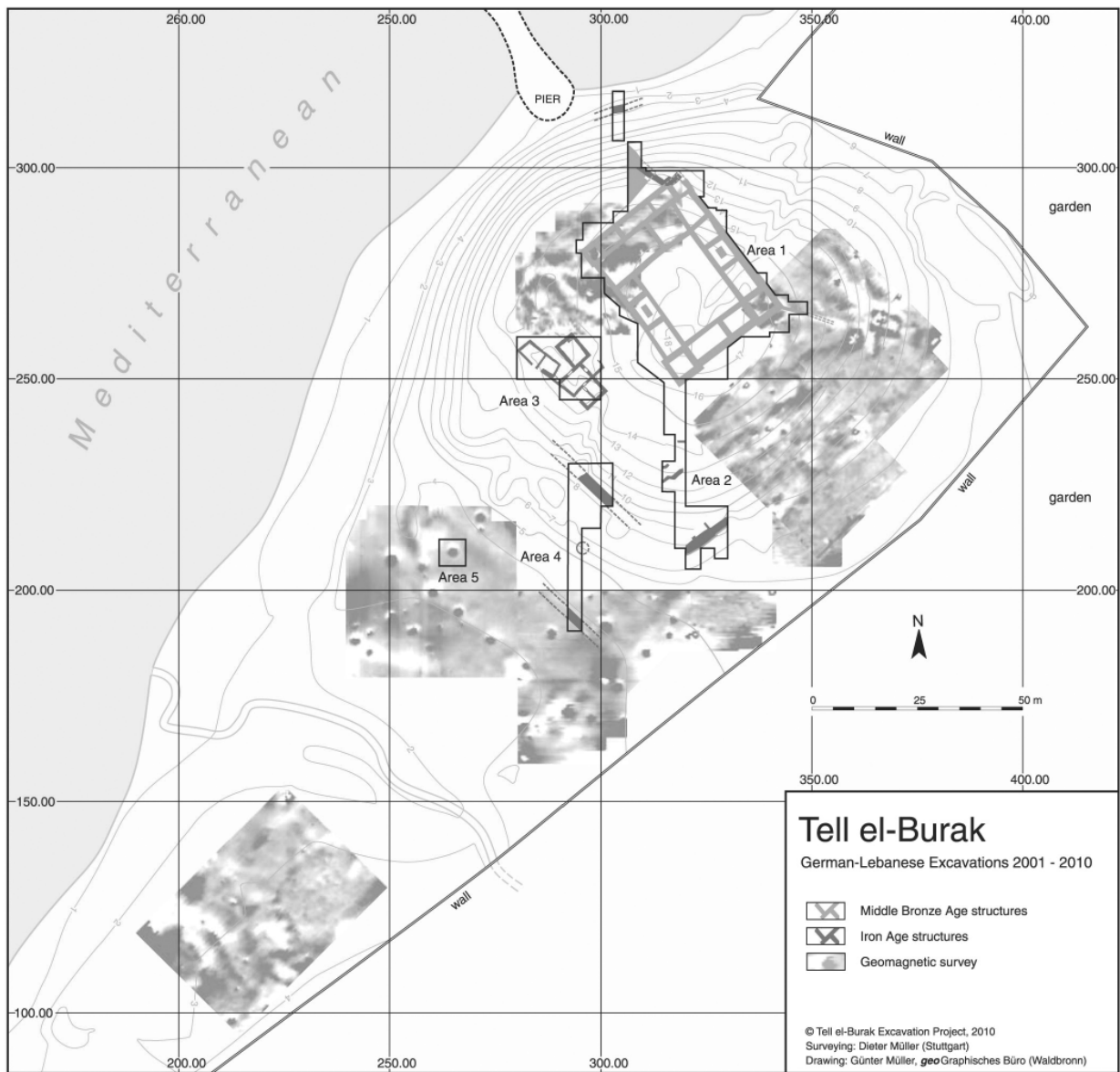

Figure 1. Topographical plan of Tell el-Burak with excavation areas

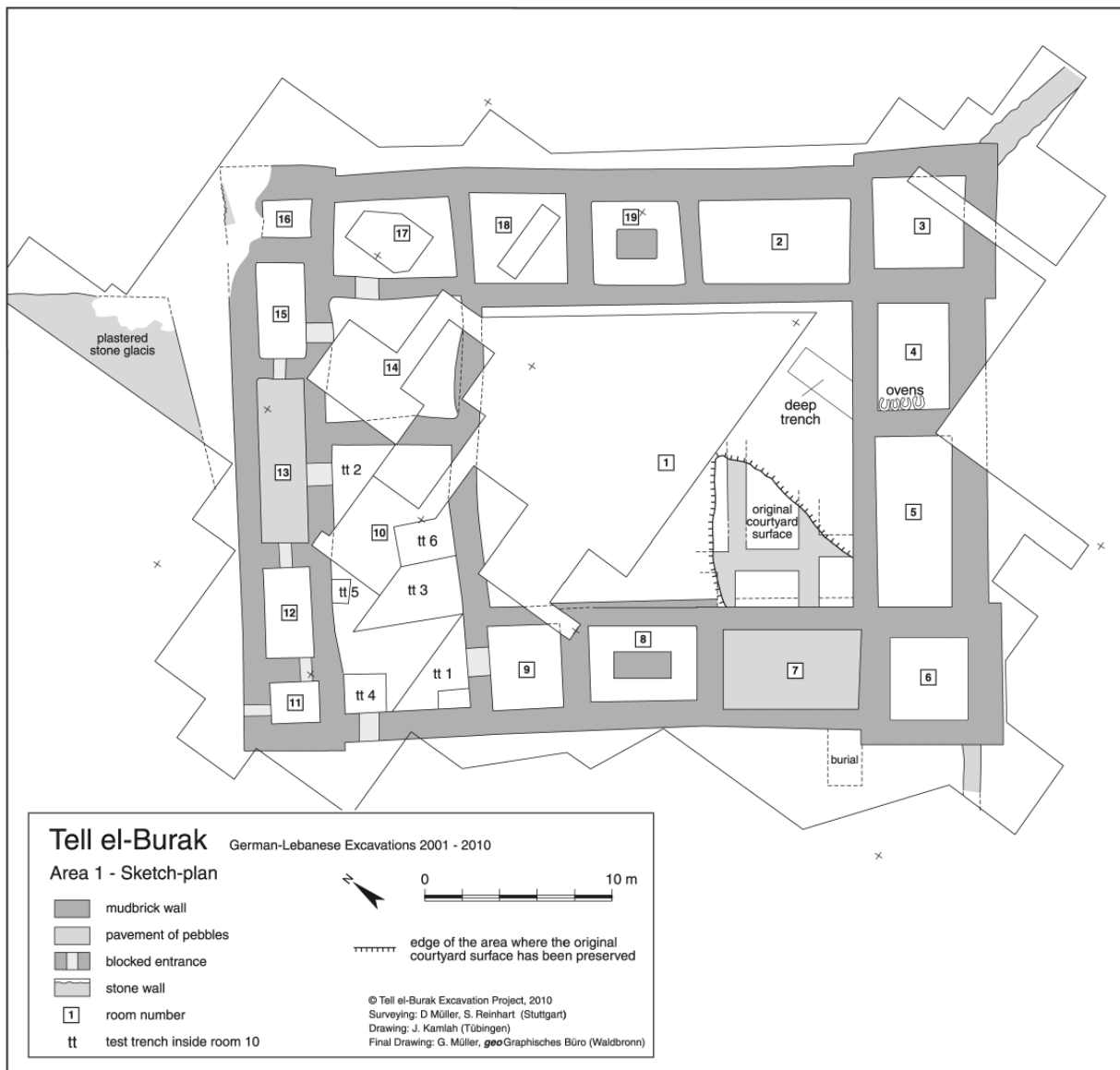

Figure 2. Plan of the monumental mud-brick building at Tell el-Burak

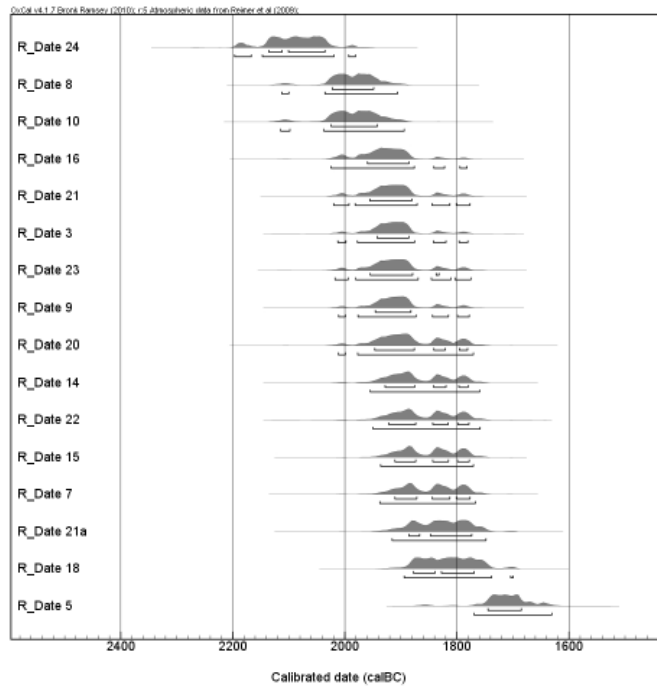

Figure 3. Middle Bronze Age radiocarbon dates from Tell el-Burak.

R-Date	TB-No.	Lab.-No.	Material	Find Context	Radiocarbon Date (BP)	Calibrated Date (BC)
3	32/26:63	KIA 26683	Charred seed: <i>triticum monococc./dicocc</i>	Deep trench in central courtyard Room 1	3564 ± 25	1890
5	31/25:85	KIA 26686	Charcoal	Burial outside Room 7	3411 ± 25	1734; 1716; 1691
7	30/27:31b	KIA 28159	Pulverized charcoal	Fill under floor of painted Room 10	3528 ± 27	1880; 1838; 1831
8	29/28:11a	KIA 28160	Charcoal	Room 11: backfill of 2nd MB phase	3622 ± 24	2009; 2002; 1976; 1965
9	29/28:11b	KIA 28161	Charcoal	Room 11: backfill of 2nd MB phase	3560 ± 26	1886
10	29/28:20	KIA 42708	Charred seeds: <i>fabaceae</i>	Room 11: backfill of 2nd MB phase	3619 ± 29	1975
14	TB 10-BP002	VERA-5572	Charred seeds: 2 <i>vitis vinifera</i>	Room 10: backfill of 2nd MB phase	3540 ± 30	1960–1760
15	TB 10-BP003	VERA-5573	Charred seeds: 1,5 frag. of <i>vicia ervilia</i>	Room 10: backfill of 2nd MB phase	3530 ± 25	1940–1770
16	TB 10-BP004	VERA-5574	Charred seeds: 3 frag. of <i>triticum monococc./dicocc.</i>	Room 10: backfill of 2nd MB phase	3575 ± 30	2030–1870
18	TB 10-BP008	VERA-5576	Charred seeds: 3 frag. of <i>olea europaea</i>	Deep trench north of Rooms 15–16: floor outside	3490 ± 30	1900–1730
20	TB 10-BP013	VERA-5578	Charred seed: 1 <i>triticum monococc./dicocc.</i>	Deep trench north of Rooms 15–16: floor outside	3550 ± 35	1980–1770
21	TB 10-BP014	VERA-5579	Charred seed: 1 frag. of <i>olea europaea</i>	Deep trench north of Rooms 15–16: floor outside	3565 ± 30	2020–1870
21a	TB 10-BP014	VERA-5579HS	Charred seed: 1 frag. of <i>olea europaea</i>	Deep trench north of Rooms 15–16: floor outside	3510 ± 30	1920–1740

Figure 4. (continued next page)

22	TB 10-BP017	VERA-5580	Charred seeds: 2 <i>triticum</i> spp.	Deep trench north of Rooms 15–16: plaster at foundation wall	3535 ± 30	1950–1750
23	30/29:16	KIA 44711	Charcoal	Plastered stone glacis northern slope	3562 ± 31	1981–1869
24	31/29:20	KIA 44712	Charcoal	Room 15: floor of 1st MB phase	3699 ± 28	2147–2020

Figure 4. Material and contexts of the Middle Bronze Age Carbon 14 dates from Tell el-Burak

MB I (Low)	2000–1800 BC
MB I (Very Low)	1900–1700 BC
MB II (Low)	1800–1600/1550 BC
MB II (Very Low)	1700–1600/1550 BC

Figure 5. Relative and absolute chronology

Type	Percentage of Assemblage
Jars (Type 1)	13%
Cooking pots (Type 2)	8%
Jugs (Type 5)	4%
Shallow bowls (Type 3)	3%
Deep bowls (Type 4)	2%
Juglets (Type 6)	1%
Bases	41%
Handles	24%
Total	100%

Figure 6. Categories of types and their relative occurrence in the Middle Bronze Age pottery assemblage of Tell el-Burak

1	Jar /Storage jar; smooth paste that is well refined and well fired, slight core. Wheel-made. Color: 5YR 7/4 pink. Quartz sand and calcareous inclusions (infrequent).
2	Jar /Storage jar; smooth paste that is well refined with a thin core. Wheel-made. Color: 2.5YR 6/6 light red. Quartz sand and calcareous inclusions (infrequent).
3	Jar /Storage jar; smooth paste that is well refined with a thin core. Wheel-made. Color: 2.5YR 6/6 light red. Quartz sand and calcareous inclusions (infrequent).
4	Jar /Storage jar; smooth paste that is poorly refined with a faint core. Wheel-made. Color: 7.5YR 6/4 light brown. Quartz sand and calcareous inclusions (frequent).
5	Storage jar; smooth paste that is well refined and well fired, no core. Wheel-made. Color: 10YR 8/3 very pale brown. Quartz sand, calcareous inclusions in different sizes fine particles are frequent; iron oxide.
6	Storage jar; smooth paste that is well refined and well fired, no core. Wheel-made. Color: 5YR 7/6 reddish yellow. Quartz sand and calcareous inclusions (infrequent).
7	Jar/Storage jar; smooth paste that is well refined, well fired with no core. Color: 5YR 4/6 yellowish red. Inclusions calcareous (infrequent) and quartz sand (frequent).
8	Jar/Storage jar; smooth paste that is well refined, well fired with no core. Wheel-made. Color: 10YR 7/4 very pale brown. Fine calcareous inclusions (frequent) and quartz (infrequent).
9	Jar/Storage jar; smooth paste that is well refined, well fired with a faint core. Wheel-made. Color: 7.5 YR 7/4 pink. Calcareous inclusions (frequent).
10	Jar/Storage jar; smooth paste that is well refined, well fired with no core. Color: 10YR 7/4 very pale brown. Fine calcareous inclusions (frequent) and quartz (infrequent).
11	Jar/Storage jar; rough fabric that is well fired with a thin core. Wheel-made. Color: 5YR 6/6 reddish yellow. Calcareous inclusions (frequent) and quartz sand.
12	Jar/Storage jar; smooth paste that is well refined, well fired with no core. Wheel-made. Color: 7.5YR 6/6 reddish yellow. Fine calcareous inclusions (frequent) and quartz (infrequent).
13	Jar/Storage jar; rough fabric that is very coarse, poorly refined and poorly fired. Wheel-made. Color: 10YR 6/4 yellowish brown. Calcareous inclusions (frequent).
14	Jar/Storage jar; smooth paste that is well refined with a thin core. Wheel-made. Color: 10 YR 7/4 very pale brown. Fine calcareous inclusions (frequent) and quartz sand (frequent).
15	Storage jar; smooth paste that is porous and well refined. Thin core. Thin black painted band under rim. Color: 7.5 YR 6/6 reddish yellow. Fine calcareous inclusions (frequent) and quartz sand (frequent).
16	Storage jar; rough paste that is poorly refined and fired. Thick core. Wheel-made. Color: 2.5 YR 6/8 reddish yellow. Large calcareous inclusions (frequent) and iron oxide.
17	Jar/Storage jar; rough paste that is well refined and fired. Thin core. Wheel-made. Color: 2.5 YR 6/8 reddish yellow. Fine calcareous inclusions (frequent) and quartz sand.
18	Jar/Storage jar; rough paste that is well refined and fired. Thin core. Color: 2.5 YR 6/8 reddish yellow. Fine calcareous inclusions (frequent) and quartz sand.

Figure 7. Description of jars found on Figure 8

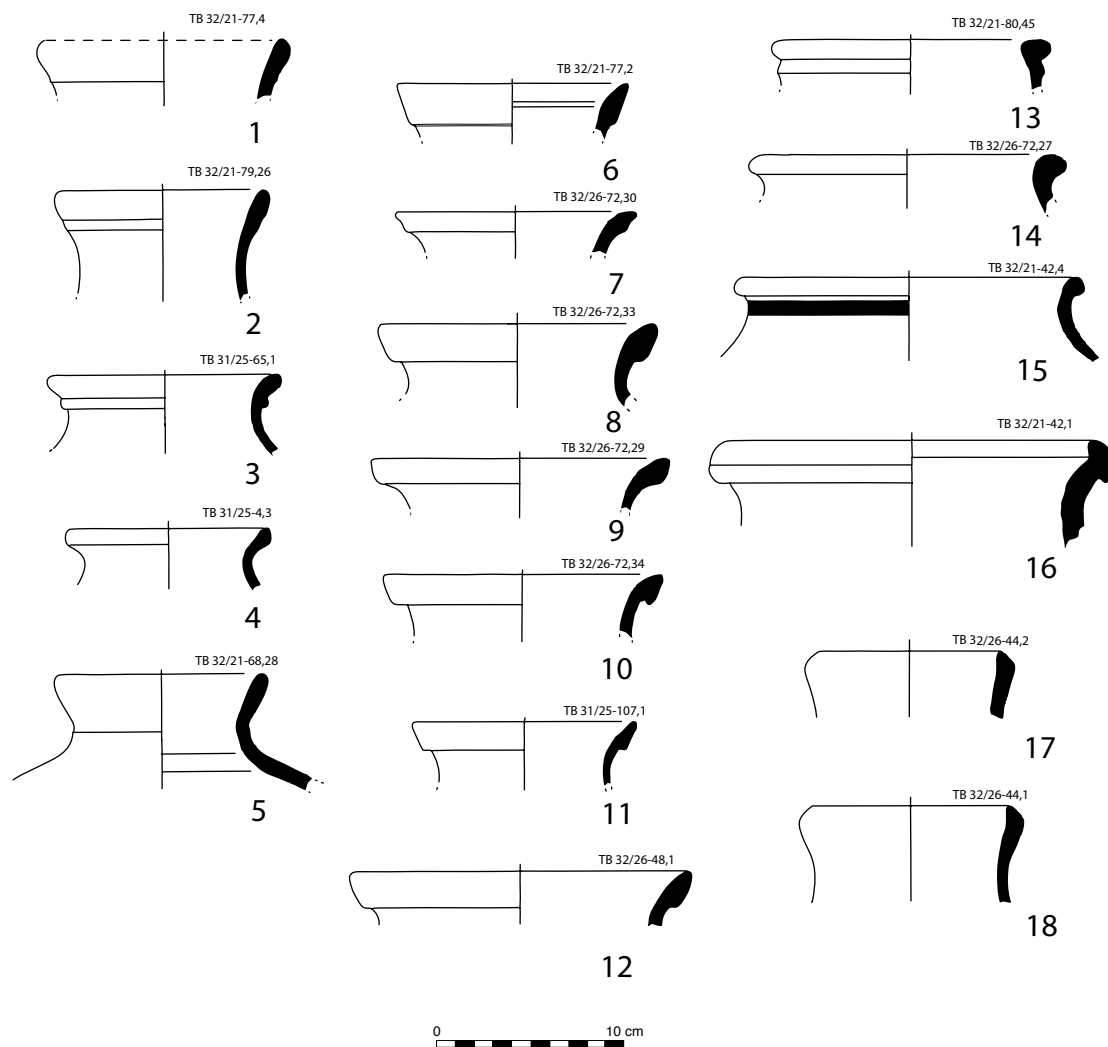

Figure 8. Jars

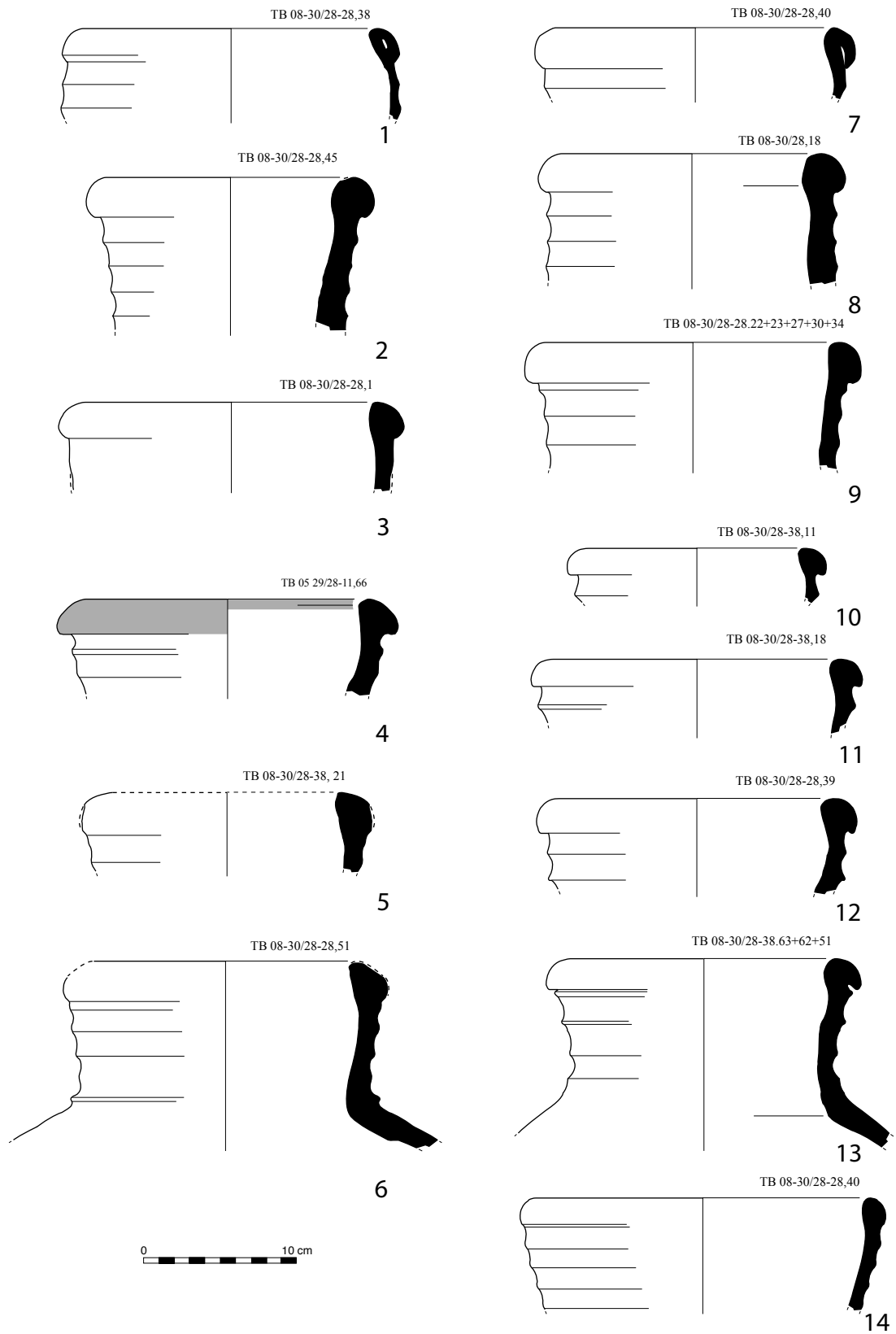

Figure 9. Ridged-Neck Pithoi

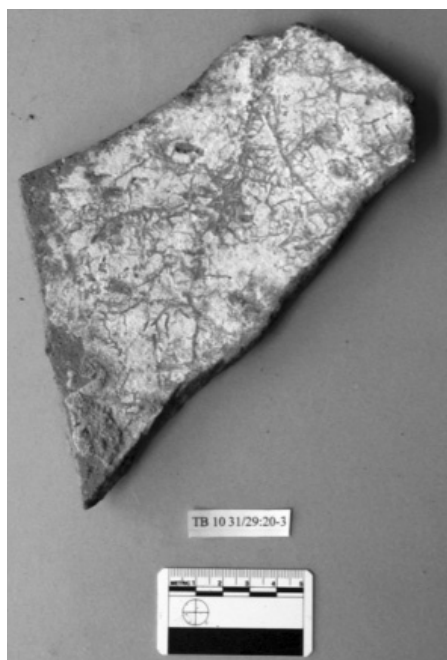

Figure 10. White plaster covering the inside of a body sherd belonging to a Ridged-Neck Pithos from Room 13

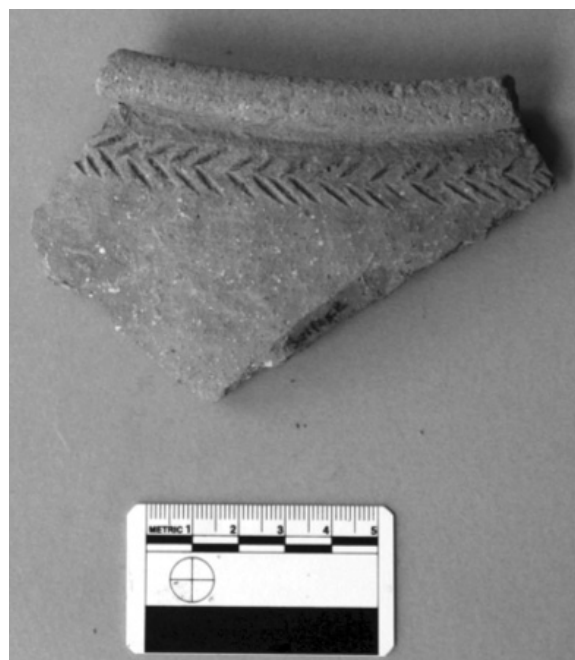

Figure 11. Gutter rim cooking pot with chevron pattern

1	Cooking pot; smooth paste that is poorly refined and poorly fired. Wheel-made. Color: 5YR 7/4 pink. White and gray calcareous inclusions and quartz inclusions (infrequent).
2	Cooking pot; smooth paste that is poorly refined and poorly fired. Wheel-made. Color: 5YR 7/4 pink. White and gray calcareous inclusions and quartz inclusions (infrequent).
3	Cooking pot; smooth paste that is poorly refined and poorly fired. Wheel-made. Color: 5YR 7/4 pink. White and gray calcareous inclusions and quartz inclusions (infrequent).
4	Cooking pot; smooth paste that is poorly refined and poorly fired. Wheel-made. Color: 5YR 7/4 pink. White and gray calcareous inclusions and quartz inclusions (infrequent).
5	Cooking pot; smooth paste that is poorly refined and poorly fired. Wheel-made. Color: 5YR 7/4 pink. White and gray calcareous inclusions and quartz inclusions (infrequent).
6	Cooking pot; coarse ware that is poorly refined and poorly fired. Color: 10R 5/6 red. Calcareous inclusions (frequent), gray rhombs (calcite?), black rhombs (iron oxide?).
7	Cooking pot; coarse ware that is poorly refined and poorly fired. Color: 10R 5/6 red. Calcareous inclusions (frequent), gray rhombs (calcite?), black rhombs (pyrite).
8	Folded rim krater; rough paste that is poorly refined and poorly fired with a thick core. Incised decoration. Color: 7.5 YR 6/6 reddish yellow. Large Calcareous (frequent) and quartz inclusions (frequent).
9	Cooking pot; smooth paste that is poorly refined and poorly fired with a thick core. Wheel-made. Color: 7.5YR 6/4 light brown. Calcareous inclusions (frequent).
10	Cooking pot?; smooth paste that is poorly refined, but well fired. Very thin core. Wheel-made. Color: 5YR 5/6 yellowish red. Quartz (very frequent) and calcareous inclusions (infrequent). The high level of quartz suggests this may not be a cooking pot.

Figure 12. Description of cooking pots and kraters found on Figure 13

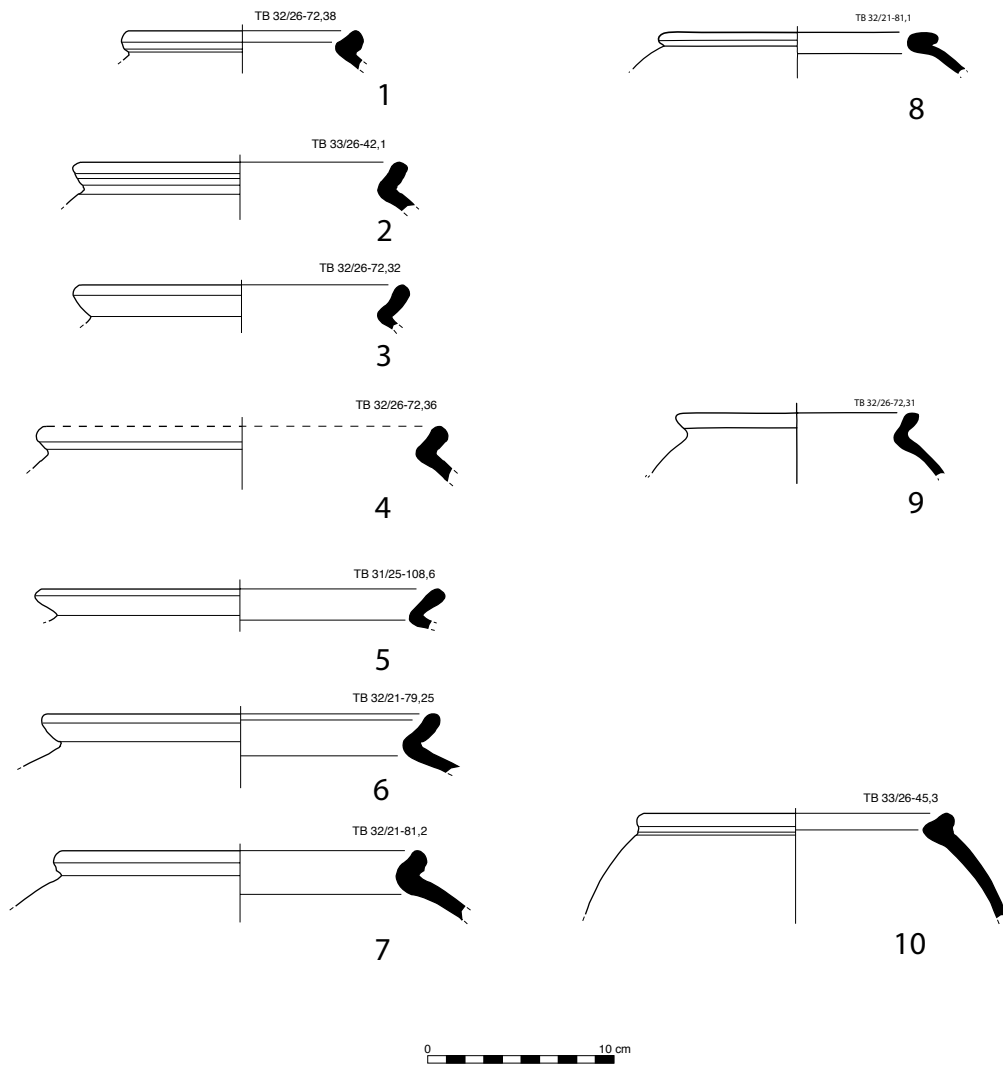

Figure 13. Cooking pots and kraters

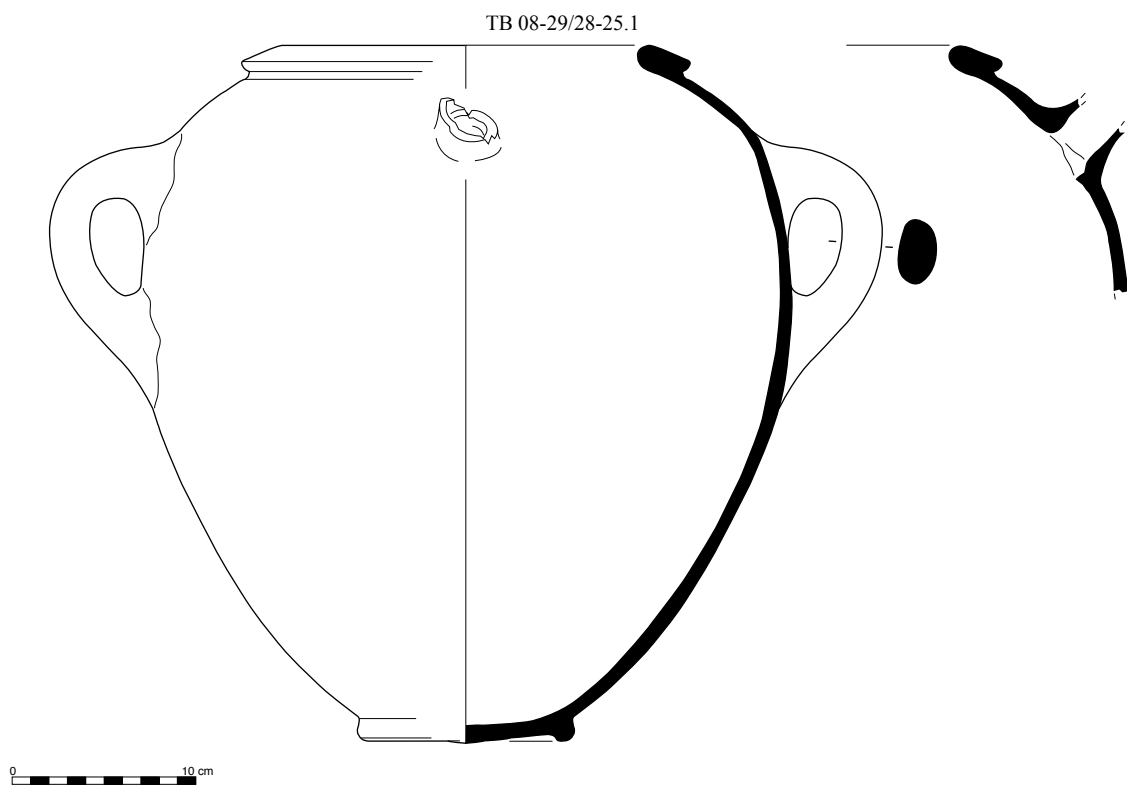

Figure 14. Folded rim krater with spout



Figure 15. Folded rim krater with spout in situ

1	Hemispherical bowl; smooth, well-refined paste that is well fired with no core. Wheel-made. Color: 5YR 6/6 reddish yellow. Calcareous inclusions (infrequent) and quartz (infrequent).
2	Hemispherical bowl; smooth, well-refined paste that is well fired with a thin core. Wheel-made. Color: 5YR 6/6 reddish yellow. Calcareous inclusions and quartz (frequent).
3	Hemispherical bowl; smooth, well-refined paste that is well fired with no core. Wheel-made. Color: 5YR 6/6 reddish yellow. Calcareous inclusions (infrequent) and quartz (infrequent).
4	Shallow bowl; smooth paste that is well refined and well fired, thin core. Color: 5YR 6/6 reddish yellow. Quartz sand, calcareous inclusions (infrequent), iron oxide (infrequent).
5	Shallow bowl; smooth paste that is well refined and well fired, thin core. Wheel-made with interior horizontal burnish. Color: 7.5YR 7/6 reddish yellow. Quartz sand, calcareous inclusions (infrequent).
6	Shallow bowl; smooth paste that is well refined and well fired, thick core. Wheel-made. Color: 7.5YR 7/6 reddish yellow. Quartz sand, calcareous inclusions, and iron oxide.
7	Carinated bowl; rough paste that is poorly refined, thin walls and thin core. Not particularly well fired. Traces of red slip. Color: 5YR 5/6 yellowish red. Calcareous (frequent) and quartz sand inclusions (frequent).

Figure 16. Description of shallow bowls found on Figure 17

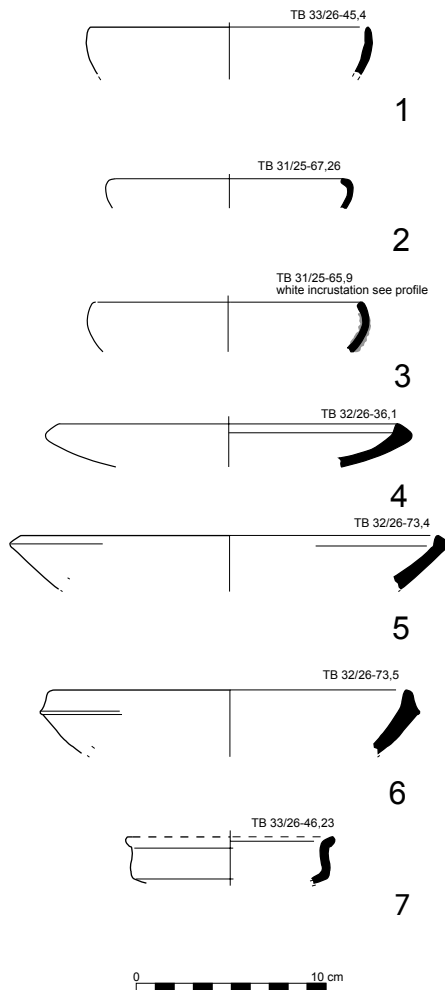

Figure 17. Shallow Bowls

1	Necked bowl; smooth thin ware that is well refined and well fired, no core. Slipped in red and horizontally burnished on wheel. Color: Fabric 7.5YR 7/6 reddish yellow, Slip 10R 4/8 Red. Calcareous inclusions, iron oxide, and mica.
2	Necked bowl; porous ware well refined, well fired. Slipped in red and vertically burnished. Color: Fabric 7.5YR 8/4 pink, slip 10R 4/8 red. Quartz sand and calcareous inclusions (infrequent).
3	Bowl; smooth paste that is well refined and well fired, thin core. Slipped in red. Color: fabric 7.5YR 6/6 reddish yellow, slip 10R 4/6 red. Quartz sand, calcareous inclusions (infrequent), iron oxide (infrequent).
4	Bowl; smooth paste that is well refined and well fired, thin core. Color: 7.5YR 7/4 pink. Calcareous inclusions (infrequent).
5	Bowl; smooth paste that is well refined and well fired, thin core. Slipped in red. Color: fabric 7.5YR 7/4 pink, slip 10R 4/6 red. Calcareous inclusions (infrequent).
6	Carinated bowl; smooth paste that is well refined with a thin core. Wheel-made. Color: Fabric 5YR 6/6 reddish yellow, slip 10R 4/6 red. Calcareous (infrequent) and quartz (infrequent).
7	Carinated bowl; smooth paste that is well refined and well fired, thin core. Slipped in red. Color: fabric 7.5YR 7/4 pink, slip 10R 4/6 red. Calcareous inclusions (infrequent) and quartz inclusions.
8	Bowl; smooth paste with a medium core. Wheel-made. Color: 5YR 6/6 reddish yellow. Quartz (frequent), mica (infrequent), calcareous, and iron oxide? Inclusions (frequent).
9	Carinated bowl; smooth paste that is well refined with no core. Traces of red slip. Wheel-made. Color: fabric 7.5YR 6/6 reddish yellow, slip 10R 4/6 red. Calcareous (very infrequent) and quartz inclusions (very infrequent).
10	Bowl; smooth, porous paste with a thin core. Color: 7.5YR 6/6 reddish yellow. faint black painted band under rim. Inclusions of quartz sand (frequent).
11	Carinated bowl; smooth paste that is well refined and well fired, thin core. Color: 7.5YR 7/4 pink. Calcareous inclusions (infrequent).
12	Carinated bowl? rough paste that is well refined and well fired with a thin core. Color: 7.5YR 6/6 Reddish Yellow. Fine calcareous inclusions.
13	Bowl; smooth paste that is well refined and well fired, thin core. Color: 7.5YR 7/4 pink. Calcareous inclusions (infrequent).
14	Bowl; smooth paste that is poorly refined and poorly fired, thick core. Color: 7.5YR 6/6 reddish yellow. Quartz (frequent) and iron oxide inclusions.
15	Bowl/cooking pot? smooth paste that is well refined and well fired, thin core. Color: 5YR 6/6 reddish yellow. Quartz sand, calcareous inclusions (infrequent), iron oxide (infrequent).

Figure 18. Description of deep bowls found on Figure 19

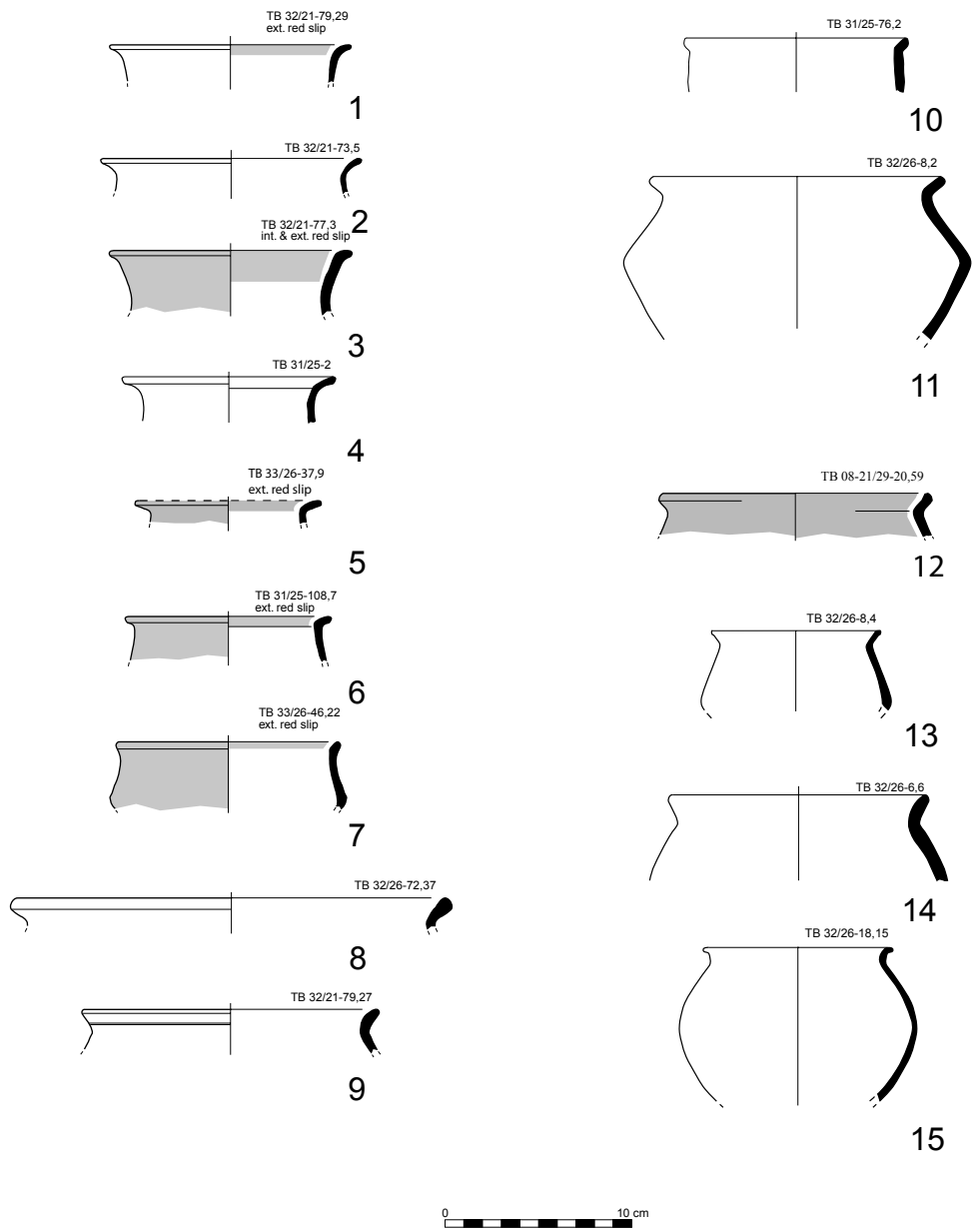

Figure 19. Deep bowls

1	Jug/Jar? smooth paste that is poorly refined thick core. Color: 7.5YR 6/6 reddish yellow. Calcareous inclusions, quartz sand, and iron oxide.
2	Jug; smooth paste that is well refined and well fired, no core. Color: 5YR 7/6 reddish yellow. Quartz sand and calcareous inclusions (infrequent).
3	Jug; smooth, very soft paste that is well refined with no core. Well fired. Color: fabric 10YR 7/4 very pale brown. Calcareous (very infrequent) and quartz inclusions (very infrequent).
4	Jug; smooth paste that is well refined and well fired, thin core. Color: 7.5YR 7/4 pink. Calcareous inclusions (infrequent) and quartz sand inclusions.

Figure 20. Description of jugs on Figure 21

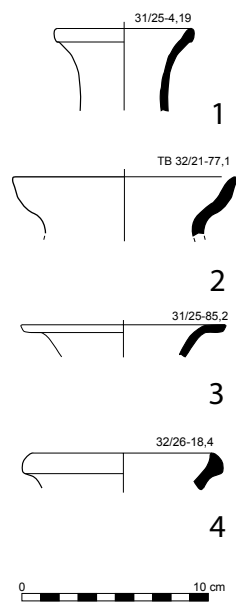

Figure 21. Jugs



Figure 22. Piriform juglet with button base and traces of red slip (Burial Context)

1	Piriform juglet; smooth paste that is well refined, well fired with a faint core. Color: 7.5 YR 7/4 pink. Calcareous inclusions (infrequent).
2	Piriform juglet; smooth, very soft paste that is well refined with no core. Well fired. Color: fabric 10YR 7/4 very pale brown. Calcareous (very infrequent) and quartz inclusions (very infrequent).
3	Piriform juglet; smooth paste that is well refined, well fired with a faint core. Color: 7.5 YR 7/4 pink. Calcareous inclusions (infrequent).
4	Piriform juglet button base; smooth paste that is well refined, well fired with a faint core. Color: Smooth paste that is well refined and well fired, no core. Color: 5YR 7/6 reddish yellow. Quartz sand and calcareous inclusions (infrequent).
5	Piriform juglet button base; smooth paste that is well refined, well fired with a faint core. Color: 7.5 YR 7/4 pink. Calcareous inclusions (infrequent).
6	Piriform juglet button base; smooth paste that is well refined, well fired with a thick core. Color: 5YR 7/6 reddish yellow. Calcareous inclusions (infrequent).
7	Piriform juglet flat bottom base; smooth paste that is well refined, well fired with a faint core. Color: 7.5 YR 7/4 pink. Calcareous inclusions (infrequent).
8	Piriform juglet button base; smooth paste that is well refined, well fired with a faint core. Color: 7.5 YR 7/4 pink. Calcareous inclusions (infrequent).
9	Piriform juglet flat bottom base; smooth paste that is well refined, well fired with a faint core. Color: 7.5 YR 7/4 pink. Calcareous inclusions (infrequent).

Figure 23. Description of juglets found on Figure 24

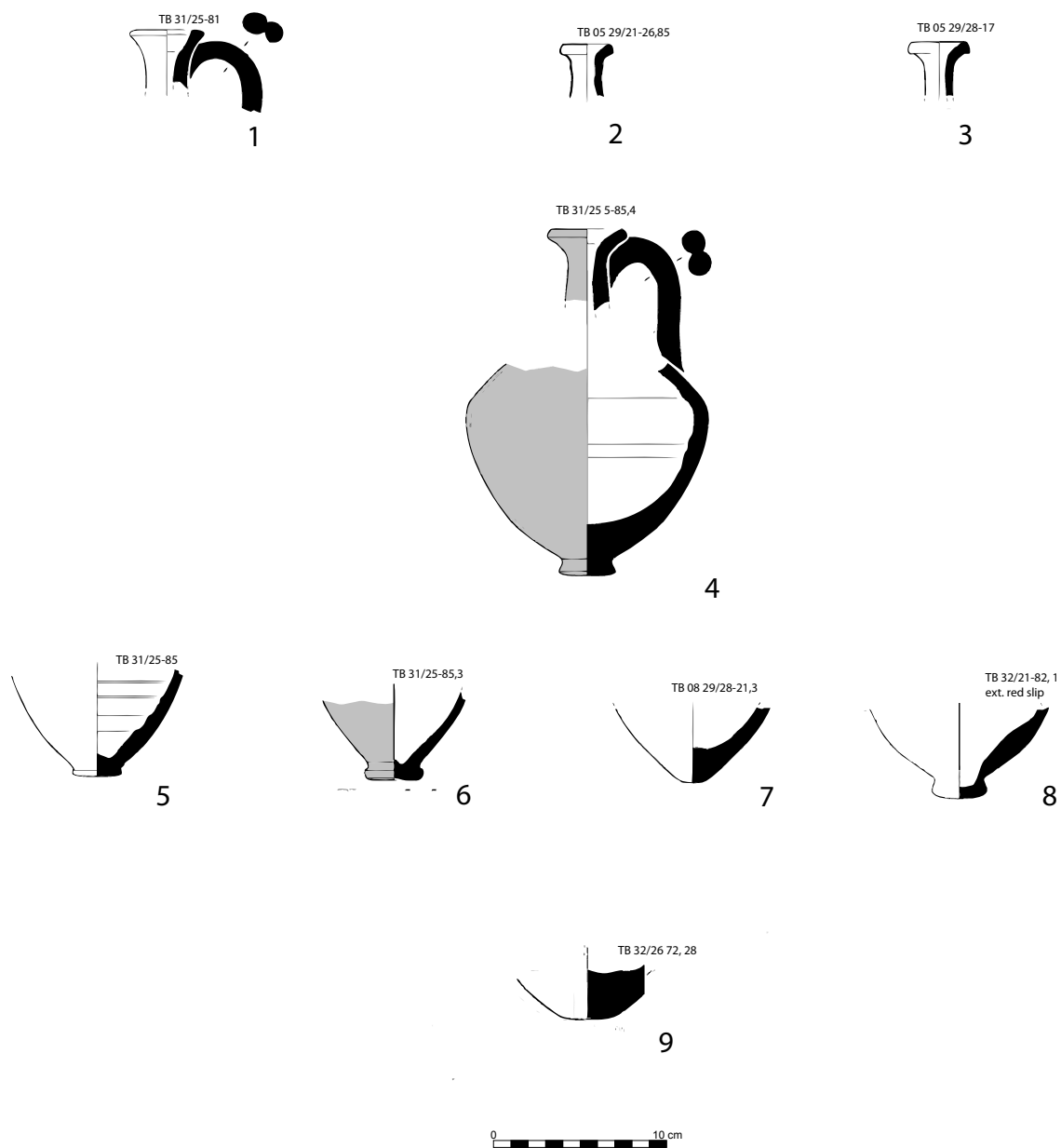
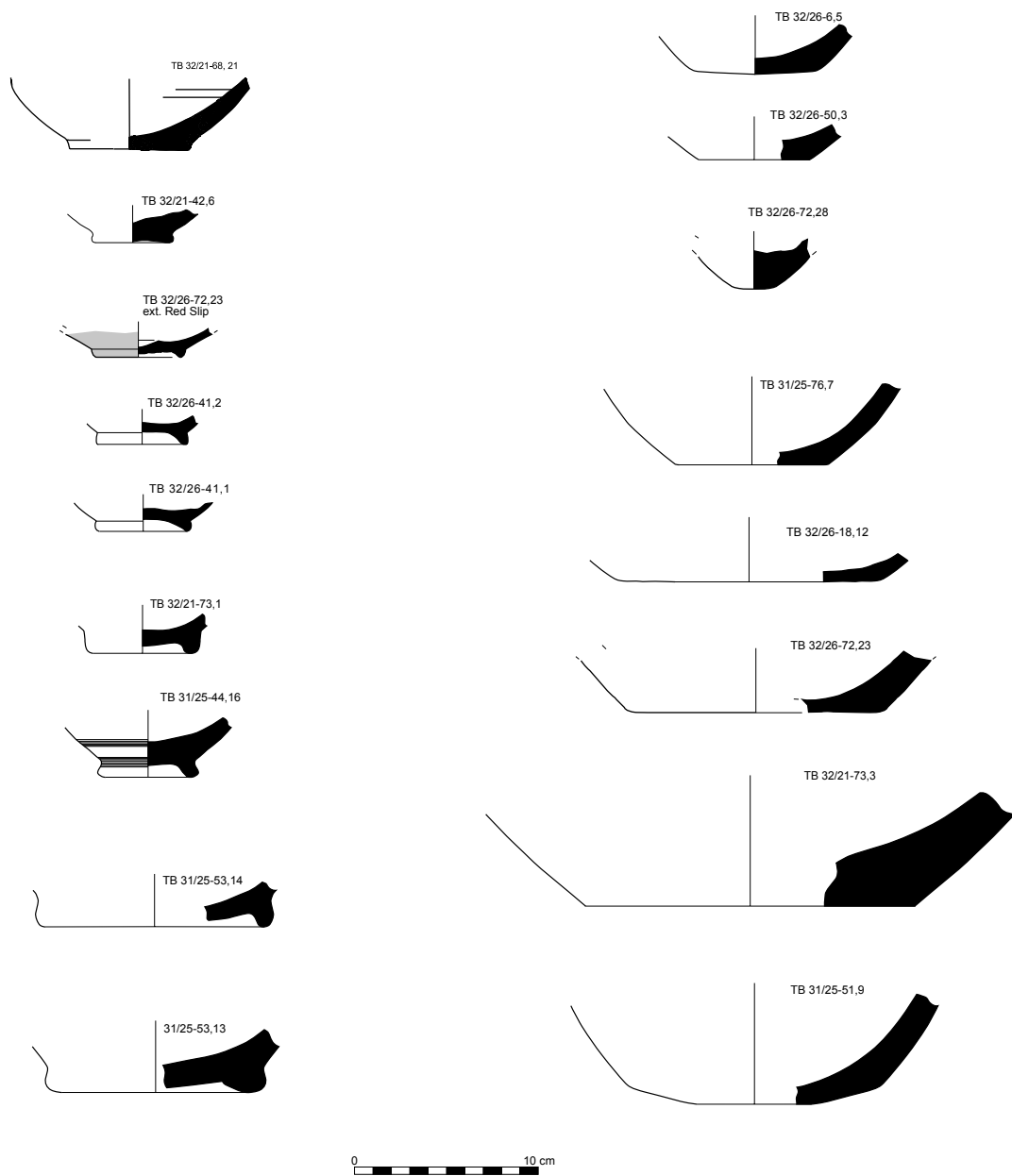

Figure 24. Juglets



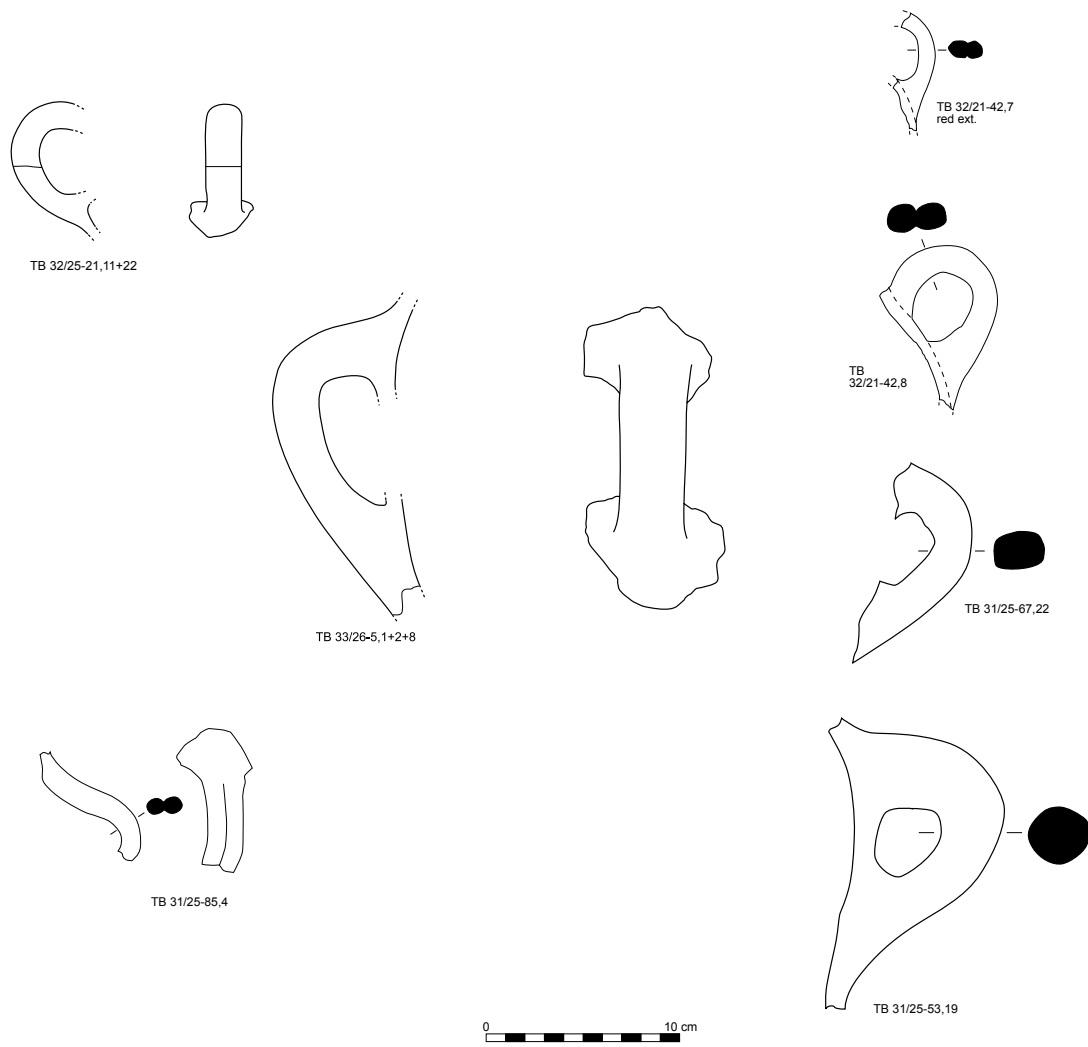

Figure 26. Handles

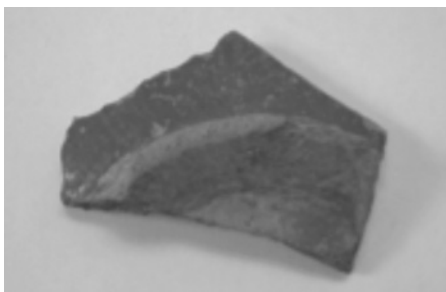

Figure 27. Red slipped and burnished ring base

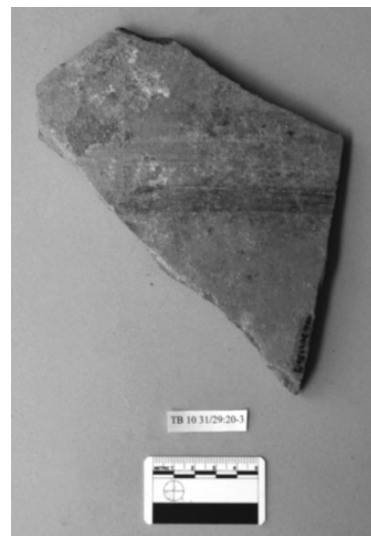

Figure 28. Monochrome painted body sherd (so-called Levantine Painted Ware)

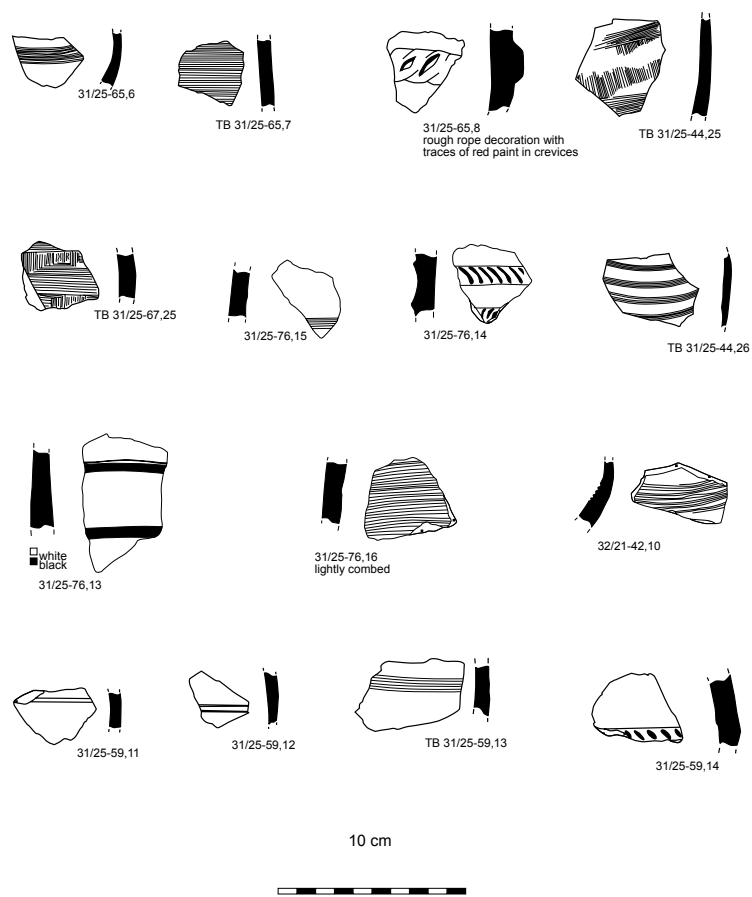

Figure 29. Decorative patterns

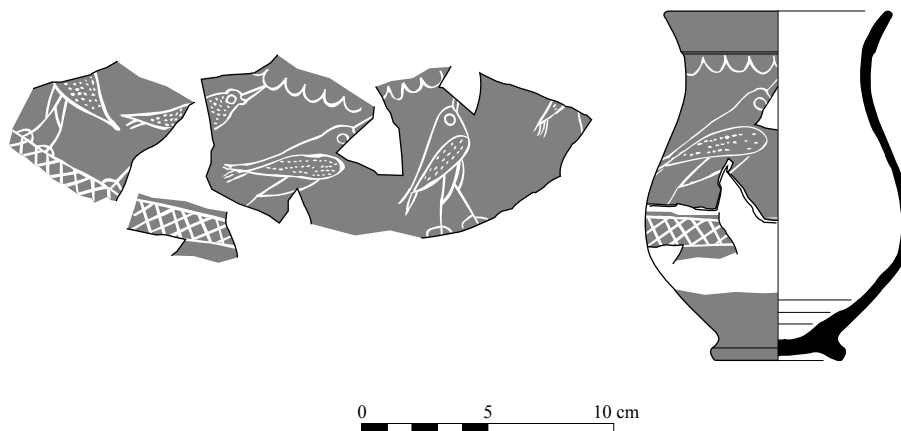

Figure 30. Tell el-Yahudiyeh vessel from a burial outside of Room 7



Figure 31. Tell el-Yahudiyeh vessel from a burial outside of Room 7



Figure 32. Three-footed Tell el-Yahudiyeh vessel, bottom part

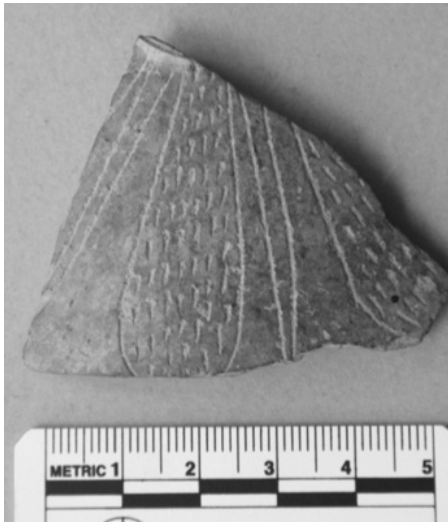

Figure 33. Three-footed Tell el-Yahudiyeh vessel, shoulder



Figure 34. Three-footed Tell el-Yahudiyeh vessel, detail with head and beak of a waterfowl (?)

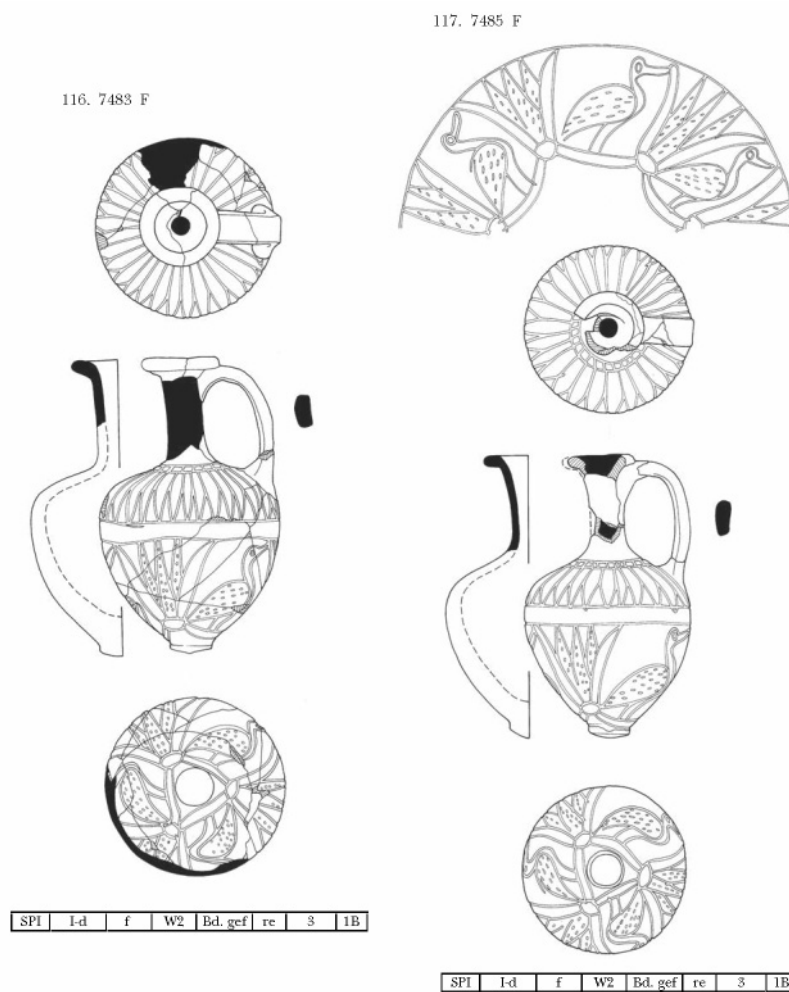

Figure 35. Juglets with birds and flower motifs from Tell el-Dab'a (after Aston and Bietak 2011: 380; Plate 26)

