

Imprecise System Reliability and Component Importance Based on Survival Signature

Geng Feng, Edoardo Patelli, Michael Beer

*Institute for Risk and Uncertainty, School of Engineering, University of Liverpool,
Liverpool, United Kingdom*

Frank P.A. Coolen

Department of Mathematical Sciences, Durham University, Durham, United Kingdom

Abstract

The concept of the survival signature has recently attracted increasing attention for performing reliability analysis on systems with multiple types of components. It opens a new pathway for a structured approach with high computational efficiency based on a complete probabilistic description of the system. In practical applications, however, some of the parameters of the system might not be defined completely due to limited data, which implies the need to take imprecisions of component specifications into account. This paper presents a methodology to include explicitly the imprecision, which leads to upper and lower bounds of the survival function of the system. In addition, the approach introduces novel and efficient component importance measures. By implementing relative importance index of each component without or with imprecision, the most critical component in the system can be identified depending on the service time of the system. Simulation method based on survival signature is introduced to deal with imprecision within components, which is precise and efficient. Numerical example is presented to show the applicability of the approach for systems.

Keywords: Imprecision; survival signature; system reliability; component importance

*Corresponding author

Email address: edoardo.patelli@liverpool.ac.uk (Edoardo Patelli)

1. INTRODUCTION

Networked systems are a series of components interconnected by communication paths. The analysis of these systems becomes more and more important as they are the backbone of our societies. Examples include the Internet, social networks of individuals or businesses, transportation network, power plant system, metabolic networks, and many others. Since the breakdown of a system may cause catastrophic effects, it is essential to be able to assess the reliability and availability of these systems. As an intrinsic feature, practical systems involve uncertainties to a significant extent. Since the reliability and performance of systems are directly affected by uncertainties, a quantitative assessment of uncertainty is widely recognized as an important task in practical engineering [1]. The obvious pathway to a realistic and powerful analysis of systems is a probabilistic approach. In practical cases there are two specific challenges that need to be addressed to obtain realistic results. First, the complexity of the system needs to be reflected in the numerical model. This goes far beyond a model based on a set of components with simple connections between them. For instance, there may be several different types of components in the same system. This variety together with the large size of real-life systems complicates the propagation of the uncertainty from the various different component types with their different performance and uncertainty characteristics to the system performance for the prediction of the system lifetime and reliability. Second, the available information for the quantitative specification of the uncertainties associated with the components is often limited and appears as incomplete information, limited sampling data, ignorance, measurement errors and so forth. The present work contributes towards a solution to these challenges.

The proposed approach is based on the survival signature, which is associated with a survival analysis [2] of systems. Survival analysis has important applications in biology, medicine, insurance, reliability engineering, demography, sociology, economics, etc. In engineering, survival analysis is typically

30 referred to as reliability analysis, and the survival function is then called re-
liability function. This survival function or reliability function quantifies the
survival probability of a system at a certain point in time. In this context, the
concept of the system signature [3] has been recognized as an important tool
to quantify the reliability of systems that consist of exchangeable components.
35 The main advantage of the system signature is its capability to separate the
structure of the system from the probabilistic model used to describe the ran-
dom failure of the system components. Recent advancements using the concept
of system signature are reported in [4]. However the use of the system signature
is associated with the assumption that all components in the system are of the
40 same type. This is a major limitation since real systems are generally formed
by more than one component type so that those systems cannot be analysed
with the system signature [5].

In order to overcome the limitations of the system signature, Coolen and
Coolen-Maturi [5] proposed the survival signature as improved concept, which
45 does not rely any more on the restriction to one component type. Specifically,
the characteristics of the components do not need to be independently and
identically distributed (*iid*). In the case of a single component type, the survival
signature is closely related to the system signature. Recent developments have
opened up a pathway to perform a survival analysis using the concept of survival
50 signature even for relatively complex systems. Coolen et al. have shown how
the survival signature can be derived from the signatures of two subsystems in
both series and parallel configuration [6], and they developed a non-parametric
predictive inference scheme for system reliability using the survival signature
[5]. Aslett et al. [7] presented the use of the survival signature for systems
55 reliability quantification from a Bayesian perspective.

In many cases, uncertainties cannot be quantified precisely since they are
characterized by incomplete information, limited sampling data, ignorance, mea-
surement errors and so on. Thus, a thorough and realistic quantitative assess-
ment of the uncertainties is quite important. Moreover, it is essential to know
60 which component with uncertainties has the biggest influence degree to the

whole system.

Component importance measure allows to quantify the importance of system components and identify the most “critical” component. It is a useful tool to find weaknesses in systems and to prioritize reliability improvement activities. Birnbaum [8] proposed a measure to find the reliability importance of a component in 1969, which is obtained by partial differentiation of the system reliability with respect to the given component reliability. An improvement or decline in reliability of the component with the highest importance will cause the greatest increase or decrease in system reliability. Several other importance measures have been introduced [9]. Improvement potential, risk achievement worth, risk reduction worth, criticality importance and Fussell-Vesely’s measure were all reviewed in Ref. [10] [11] [12] [13]. To conduct reliability importance of components in a complex system, Wang et al. [14] introduced and presented failure criticality index, restore criticality index and operational criticality index. Zio et al. [15] [16] presented generalized importance measures based on Monte Carlo simulation. The component importance measures can determine which components are more important to the system, which may suggest the most efficient way to prevent system fails.

Some of the importance measures can be computed through analytical methods, but limited to systems with few components. Traditional simulation methods provide no easy way to compute component importance [14]. In addition, in case with imprecision in the component failure, the simulation approaches become intractable.

In this paper, a novel reliability approach and component importance measure based on survival signature is proposed to analyse systems with multiple types of components. The proposed approach allows to include explicitly imprecision and vagueness in the characterization of the uncertainties of system components. The imprecision characterizes indeterminacy in the specification of the probabilistic model. That is, an entire set of plausible probabilistic models is specified using set-values (herein, interval-valued) descriptors for the description of the probabilistic model. The cardinality of the set-valued descriptors

reflects the magnitude of imprecision and, hence, the amount and quality of information that would be needed in order to specify a single probabilistic model with a sufficient confidence. In real cases the amount and quality of information to specify a probabilistic model can be limited to such an extent that the associated magnitude of imprecision makes the entire analysis meaningless. In such cases it is essential to identify those contributions to the imprecision, which influence the results most strongly. Once these are known, targeted measures and investments can be defined in order to reduce the imprecision to enable a meaningful survival analysis. For this purpose, a component importance measure is implemented to identify the most “critical” component of the system taking into account the imprecision in their characterization. Specifically, new component importance measure is introduced as the relative importance index (*RI*). Through simulation method based on survival signature, upper and lower bounds of survival function of the system or relative importance index can be got efficiently. On this basis, the survival function of system and the importance degree of components can be quantified. The proposed approaches of the improved survival signature are demonstrated by some examples.

2. SURVIVAL SIGNATURE AND SURVIVAL FUNCTION

Suppose there is one system formed by m components. Let the state vector of components be $\underline{x} = (x_1, x_2, \dots, x_m) \in \{0, 1\}^m$ with $x_i = 1$ if the i th component is in working state and $x_i = 0$ if not. $\phi = \phi(\underline{x}) : \{0, 1\}^m \rightarrow \{0, 1\}$ defines the system structure function, i.e., the system status based on all possible \underline{x} . ϕ is 1 if the system functions for state vector \underline{x} and 0 if not.

Now consider a system with $K \geq 2$ types of m components, with m_k indicating the number of components of each type and $\sum_{k=1}^K m_k = m$. It is assumed that the failure times of the same component type are independently and identically distributed (*iid*) or exchangeable. The components of the same type can be grouped together because of the random ordering of the components in the state vector, which leads to a state vector can be written as $\underline{x} = (\underline{x}^1, \underline{x}^2, \dots, \underline{x}^K)$,

with $\underline{x}^k = (x_1^k, x_2^k, \dots, x_{m_k}^k)$ representing the states of the components of type k . Coolen et al. [6] introduced the survival signature for such a system, denoted by $\Phi(l_1, l_2, \dots, l_K)$, with $l_k = 0, 1, \dots, m_k$ for $k = 1, 2, \dots, K$, which is defined to be the probability that the system functions given that l_k of its m_k components
125 of type k work, for each $k \in \{1, 2, \dots, K\}$. There are $\binom{m_k}{l_k}$ state vectors \underline{x}^k with precisely l_k components x_i^k equal to 1, so with $\sum_{i=1}^{m_k} x_i^k = l_k$ ($k = 1, 2, \dots, K$), and S_{l_1, l_2, \dots, l_K} denote the set of all state vectors for the whole system.

Assume that the random failure times of components of the different types are fully independent, and in addition the components are exchangeable within
130 the same component types, the survival signature can be rewritten as:

$$\Phi(l_1, \dots, l_K) = \left[\prod_{k=1}^K \binom{m_k}{l_k} \right]^{-1} \times \sum_{\underline{x} \in S_{l_1, l_2, \dots, l_K}} \phi(\underline{x}) \quad (1)$$

$C_k(t) \in \{0, 1, \dots, m_k\}$ denotes the number of k components working at time t . Assume that the components of the same type have a known CDF, $F_k(t)$ for type k . Moreover, the failure times of different component types are assumed independent, then:

$$P\left(\bigcap_{k=1}^K \{C_k(t) = l_k\}\right) = \prod_{k=1}^K P(C_k(t) = l_k) = \prod_{k=1}^K \binom{m_k}{l_k} [F_k(t)]^{m_k - l_k} [1 - F_k(t)]^{l_k} \quad (2)$$

135 Hence, the survival function of the system with K types of components becomes:

$$P(T_s > t) = \sum_{l_1=0}^{m_1} \dots \sum_{l_K=0}^{m_K} \Phi(l_1, \dots, l_K) P\left(\bigcap_{k=1}^K \{C_k(t) = l_k\}\right) \quad (3)$$

It is obvious from Equation 3 that the survival signature can separate the structure of the system from the failure time distribution of its components, which is the main advantage of the system signature. What is more, the survival
140 signature only need to be calculated once for any system, which is similar to the system signature for systems with only single type of components. It is easily seen that survival signature is closely related with system signature. For a

special case of a system with only one type ($K = 1$) of components, the survival signature and the Samaniego's signature [3] are directly linked to each other
145 through a simple equation, however, the latter cannot be easily generalized for systems with multiple types ($K \geq 2$) of components [5].

This implies that all attractive properties of the system signature also hold for the method using the survival signature, also the survival signature is easy to apply for systems with multiple types of components, and one could argue it
150 is much easier to interpret than the system signature.

3. GENERALIZED PROBABILISTIC DESCRIPTION OF THE FAILURE TIMES OF COMPONENTS

3.1. Introduction of Probability Box

As stated in the previous section, the probability of the failure of each component is described by the CDF, $F_k(t)$. However, it is not always possible to
155 fully characterize the probabilistic behaviour of components due to ignorance or incomplete knowledge. This lack of knowledge comes from many sources: in-adequate understanding of the underlying processes, imprecise evaluation of the related characteristics, or incomplete knowledge of the phenomena. These
160 problems can be tackled by resorting to generalized probabilistic methods, such as imprecise probabilities, see e.g. [17] [18] [19] [20]. The main problem of generalized probabilistic methods is the computational cost associated with their evaluation. In fact, these approaches required multiple probabilistic model evaluations, and often use global optimization procedures [21]. Efficient numerical
165 methods have been developed and made available in powerful toolboxes such as OpenCossan software [22] [23]. Recently, Coolen et al. have combined nonparametric predictive inference method with survival signature to analyse system reliability [24].

The generalized probabilistic model makes the uncertainty quantification a
170 rather challenging task in terms of computational cost, and the challenge comes mainly from computing the lower and upper bounds of the quantities of interest.

Let \underline{F} and \overline{F} be non-decreasing functions mapping the real line \mathfrak{R} into $[0,1]$ and $\underline{F}(x) \leq \overline{F}(x)$ for all $x \in \mathfrak{R}$. Let $[\underline{F}, \overline{F}]$ denote a set of the non-decreasing functions F on the real line such that $\underline{F}(x) \leq F(x) \leq \overline{F}(x)$. When the functions \underline{F} and \overline{F} circumscribe an imprecisely known probability distribution, $[\underline{F}, \overline{F}]$ is called a “probability box” or “p-box” [25]. Using the framework of imprecise probabilities in form of a p-box (see [26] [27]), the lower and upper CDF for the failure times of components of type k are denoted by $\underline{F}_k(t)$ and $\overline{F}_k(t)$, respectively. The lower and upper CDF bounds can be obtained by calculating the range of all distributions that have parameters within some intervals. For some distribution families, only two CDFs need to be computed to enclose the p-box. For most distribution families, however, four or more crossing CDFs need to be computed to define a p-box, see [28]. As an example, Fig. 1 depicts a free p-box whose bounds arise from a lognormal distribution with parameters intervals $\alpha = [\underline{0.5}, \overline{0.6}]$ and $\beta = [\underline{0.05}, \overline{0.1}]$.

3.2. Analytical Method to Deal with Imprecision within Components Failure Times

Lower and upper bound of the survival function for a system consisting of multiple types of components can be calculated analytically based on Coolens works for nonparametric predictive inference in [24]. As $C_k(t)$ denotes the number of k components working at time t , and it is assumed that the components can not be repaired or replaced. The lower survival function is:

$$\underline{S}_{T_S}(t) = \underline{P}(T_S > t) = \sum_{l_1=0}^{m_1} \dots \sum_{l_K=0}^{m_K} \Phi(l_1, \dots, l_K) \prod_{k=1}^K \overline{D}(C_k(t) = l_k) \quad (4)$$

where

$$\overline{D}(C_k(t) = l_k) = \overline{P}(C_k(t) \leq l_k) - \overline{P}(C_k(t) \leq l_k - 1) \quad (5)$$

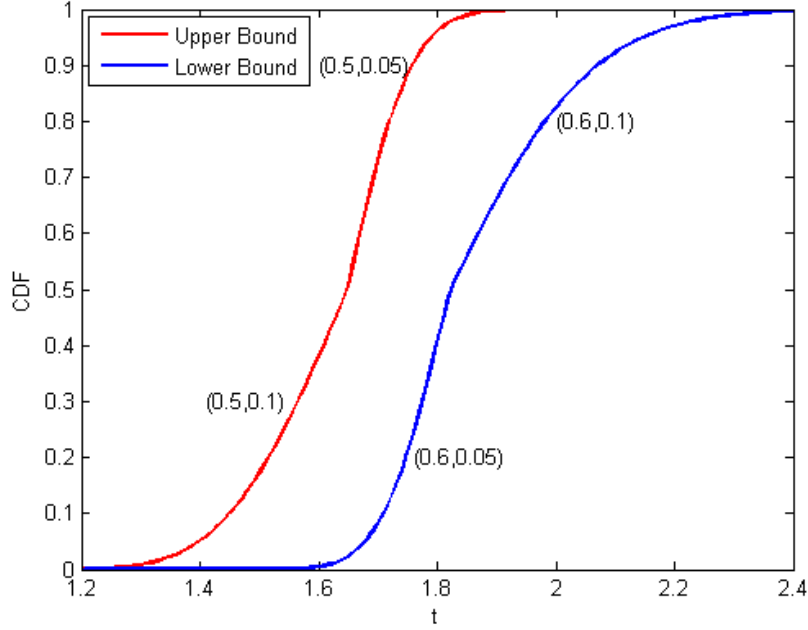

Figure 1: A distributional free p-box whose bounds arise from a lognormal distribution with parameters intervals $\alpha = [\underline{0.5}, \overline{0.6}]$ and $\beta = [\underline{0.05}, \overline{0.1}]$.

While the corresponding upper bound of the survival function is:

$$\bar{S}_{T_S}(t) = \bar{P}(T_S > t) = \sum_{l_1=0}^{m_1} \dots \sum_{l_K=0}^{m_K} \Phi(l_1, \dots, l_K) \prod_{k=1}^K \underline{D}(C_k(t) = l_k) \quad (6)$$

195 where

$$\underline{D}(C_k(t) = l_k) = \underline{P}(C_k(t) \leq l_k) - \underline{P}(C_k(t) \leq l_k - 1) \quad (7)$$

For a system with m components in one type, C_t is represented to binomial distribution, with $C_t \sim \text{Binomial}(m, 1 - F(t))$. According to stochastic dominance theory [29], C_t increases as $(1 - F(t))$ increases.

For parametric distribution, the CDF of components failure time can be
 200 expressed by $F(t | \theta)$, with $\theta \in \Theta$ (e.g. parameter $\theta \in [\underline{\theta}, \bar{\theta}]$). Therefore, there

will be a $\underline{\theta} \in \Theta$ leading to $F(t | \underline{\theta}) = \underline{F}(t)$ and a $\bar{\theta} \in \Theta$ leading to $F(t | \bar{\theta}) = \bar{F}(t)$, which holds for all t .

Here, taking an exponential distribution with parameter $\lambda \in [\lambda_1, \lambda_2]$ as an example. It is known that $\underline{F}(t) = F(t | \lambda_1) = 1 - e^{-\lambda_1 t}$ and $\bar{F}(t) = F(t | \lambda_2) = 1 - e^{-\lambda_2 t}$. C_t increases as $(1 - F(t))$ increases, so $\underline{P}(C_t \leq l) = \sum_{u=0}^l \binom{m}{u} (1 - e^{-\lambda_2 t})^{m-u} (e^{-\lambda_2 t})^u$ and $\bar{P}(C_t \leq l) = \sum_{u=0}^l \binom{m}{u} (1 - e^{-\lambda_1 t})^{m-u} (e^{-\lambda_1 t})^u$.

For a system with one type of components, the lower bound of the survival function for the system at time t becomes:

$$\underline{S}_{T_S}(t) = \underline{P}(T_S > t) = \sum_{l=0}^m \Phi(l) \binom{m}{l} (1 - e^{-\lambda_1 t})^{m-l} (e^{-\lambda_1 t})^l \quad (8)$$

and the corresponding upper bound of the survival function becomes:

$$\bar{S}_{T_S}(t) = \bar{P}(T_S > t) = \sum_{l=0}^m \Phi(l) \binom{m}{l} (1 - e^{-\lambda_2 t})^{m-l} (e^{-\lambda_2 t})^l \quad (9)$$

For a system composed of $K \geq 2$ types of components, with parameter $\lambda^k \in [\lambda_1^k, \lambda_2^k]$, the lower bound of the survival function for the system at time t is:

$$\underline{S}_{T_S}(t) = \underline{P}(T_S > t) = \sum_{l_1=0}^{m_1} \dots \sum_{l_K=0}^{m_K} \Phi(l_1, \dots, l_K) \prod_{k=1}^K \binom{m_k}{l_k} [1 - e^{-\lambda_1^k t}]^{m_k - l_k} [e^{-\lambda_1^k t}]^{l_k} \quad (10)$$

The corresponding upper bound of the survival function becomes:

$$\bar{S}_{T_S}(t) = \bar{P}(T_S > t) = \sum_{l_1=0}^{m_1} \dots \sum_{l_K=0}^{m_K} \Phi(l_1, \dots, l_K) \prod_{k=1}^K \binom{m_k}{l_k} [1 - e^{-\lambda_2^k t}]^{m_k - l_k} [e^{-\lambda_2^k t}]^{l_k} \quad (11)$$

To illustrate the method presented in this section, the lower and upper bounds of survival function for the system in Fig. 2 are calculated. The system has six components belong to two types. Results of survival signature of the system can be seen in Table 1. The failure times of the two component types are according to exponential distribution, with interval parameters $\lambda_1 \in [0.4, 1.2]$ and $\lambda_2 \in [1.3, 2.1]$, respectively.

Table 1: Survival signature of the system in Fig.2

l_1	l_2	$\Phi(l_1, l_2)$
0	0	0
0	1	0
0	2	0
0	3	0
1	0	0
1	1	0
1	2	1/9
1	3	1/3
2	0	0
2	1	0
2	2	4/9
2	3	2/3
3	0	1
3	1	1
3	2	1
3	3	1

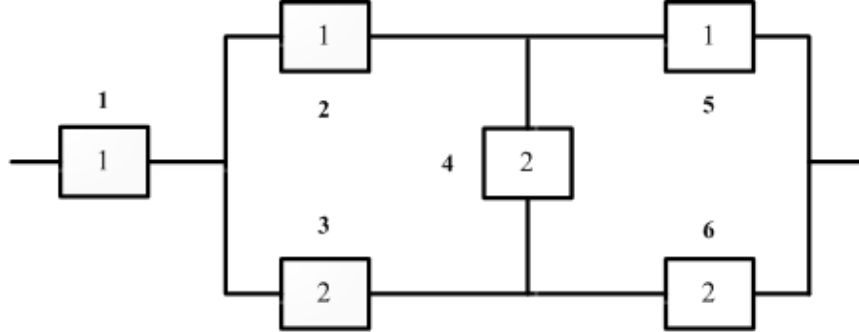

Figure 2: System with two types of components.

220 This leads to lower and upper bounds of survival functions of the system as seen in Fig. 3.

For other distribution types, like Weibull distribution or gamma distribution, if the shape parameter is fixed, the upper and lower bounds of survival function can be deduced in a similar way as shown for the exponential distribution type.
 225 However, if shape parameter is in an interval, finding the lower bound of survival function reduces to an optimisation problem over one variable (shape parameter) only. Also, if all the parameters have interval values, by means of simulation method is a replacement to get the probability bounds of the survival function.

3.3. Simulation Method to Deal with Imprecision within Components Failure

230 *Times*

Let use the system in Fig. 2 as an example to illustrate the simulation method. The survival signature represents the probability that the system works given that the number of components of each type that are working. The system in Fig. 2 is equivalent to a system composed by two components that can be
 235 in four status (status 0 to status 3) as shown in 1. Each status represents the number of the working components.

The method used to simulate the survival function is derived from the approach proposed in [30]. The simulation approach requires the following steps:

(1) Sampling the transition times of the first component type, hence a sequence
of transition time t_1 , t_2 and t_4 can be got; (2) Repeating the procedure of step
(1) for the component type 2, which will obtain 4 additional transition times;
(3) Reordering all the transition times of (t_1, t_2, \dots, t_8) ; (4) For each time interval
the probability that the system functions can be computed based on survival
signature; (5) Repeating the steps (1) to (4) for n system histories and averaging
the obtained results; (6) The system probability of survive over the time t is
obtained by averaging the values of survival function.

The above simulation procedures are used for components without imprecision, if there exist imprecision within components failure times, just adding another loop to simulate the components' imprecise parameters. Fig. 3 shows
the lower and upper bounds of survival function obtained by simulation method
and compared with the analytical solution, and showing a perfect agreement.

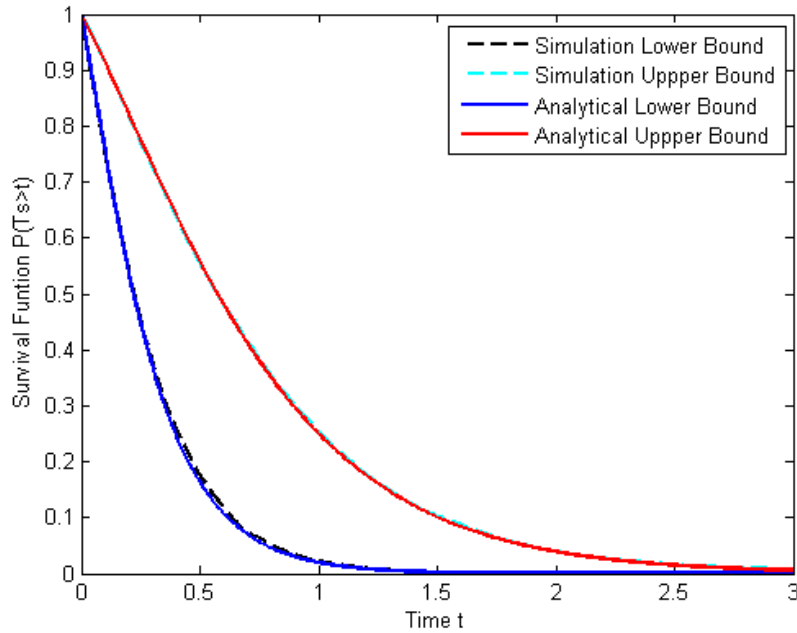

Figure 3: Lower and upper bounds of the survival function obtained by simulation and analytical method.

The simulation method can be used for analysing any systems with general imprecision. Suppose components failure times of type 1 and type 2 obey Weibull distribution and gamma distribution, respectively. Their imprecise parameters can be seen in Table 2.

Table 2: Imprecise distribution parameters of components in a system

Component type	Distribution type	Parameters (α, β)
1	Weibull	$([1.2, 1.8], [2.3, 2.9])$
2	Gamma	$([0.8, 1.6], [1.3, 2.1])$

It is difficult to get the bounds of survival function by analytical method, however, this problem can be tackled through simulation method. The results are shown in Fig. 4.

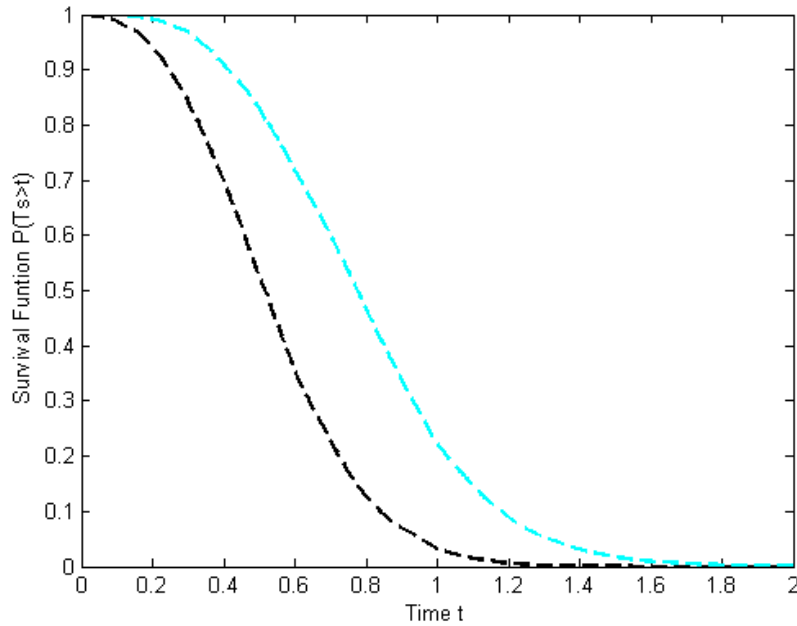

Figure 4: Lower and upper bounds of survival function by simulation method.

4. IMPORTANCE MEASURE OF A SPECIFIC COMPONENT

260 4.1. Definition of Relative Importance Index

An important objective of a reliability and risk analysis is to identify those components or events that are most important (critical) from a reliability/safety point of view. These components should be given priority with respect to improvements or maintenance. Importance measures are important tools to evaluate and rank the impact of individual components within a system [31], which will allow one to study the relationship among components and the system. Importance measures have many applications in probabilistic risk analysis and there are many approaches based on various measures of influence and response [32]. These importance measures provide a numerical rank to determine which components are more critical to system failure or more important to system reliability improvement.

A new importance measure is introduced herein as relative importance index indicated by RI , which is utilized to quantify the difference between the probability that the system functions if the i th component works and the probability that the system functions if the i th component is not working. The measure $RI_i(t)$ expresses the importance degree of a specific component during the survival time.

The relative importance index $RI_i(t)$ can be expressed as follows:

$$RI_i(t) = P(T_S > t \mid T_i > t) - P(T_S > t \mid T_i \leq t) \quad (12)$$

Where, $P(T_S > t \mid T_i > t)$ represents the probability that the system functions if the i th component works; $P(T_S > t \mid T_i \leq t)$ represents the probability that the system functions knowing that the i th component has failed.

The relative importance index $RI_i(t)$ is a function of time and it reveals the trend of the survival functions $P(T_S > t \mid T_i > t)$ and $P(T_S > t \mid T_i \leq t)$ of the system. This measure quantifies the degree of the influence of imprecision in each component characterization, i. e., the bigger the value of $RI_i(t)$, the bigger is the influence of the imprecision of the i th component on the estimation of

the system reliability at a specific time t , and vice versa. At each point in time the largest RI over all components shows the most “critical” component. This helps to allocate resources for inspection, maintenance and repair in an optimal
 290 manner over the lifetime of a system.

Taking imprecise probabilistic characterizations of the component failure probabilities into account, the set of all possible probability distribution functions can be represented as distributional p-boxes [28] indicated with $M : P \in M$. The relative importance index can be defined as:

$$RI_i(t | P) = P(T_S > t | T_i > t) - P(T_S > t | T_i \leq t) \quad (13)$$

Therefore, the lower and upper bounds of relative importance index are:

$$\underline{RI}_i(t) = \inf_{P \in M} RI_i(t | P) \quad (14)$$

$$\overline{RI}_i(t) = \sup_{P \in M} RI_i(t | P) \quad (15)$$

4.2. Illustrative Example

Now let calculate the relative importance index of component 4 of the system in section 3.2. First calculate the survival signature of the system in Fig. 5 and Fig. 6, which represents the component 4 of type 2 works and fails at time t
 295 respectively.

The survival signature of the two circumstances can be expressed as $\widetilde{\Phi}_1(l_1, l_2)$ and $\widetilde{\Phi}_0(l_1, l_2)$, and the results can be seen in Table 3 and Table 4 respectively. So:

$$\begin{aligned} RI_i(t | P) &= P(T_S > t | T_i > t) - P(T_S > t | T_i \leq t) \\ &= \sum_{l_1=0}^{m_1} \sum_{l_2=0}^{m_2-1} \widetilde{\Phi}_1(l_1, l_2) P\left(\bigcap_{k=1}^2 \{C_k(t) = l_k\}\right) - \sum_{l_1=0}^{m_1} \sum_{l_2=0}^{m_2-1} \widetilde{\Phi}_0(l_1, l_2) P\left(\bigcap_{k=1}^2 \{C_k(t) = l_k\}\right) \\ &= \sum_{l_1=0}^{m_1} \sum_{l_2=0}^{m_2-1} [\widetilde{\Phi}_1(l_1, l_2) - \widetilde{\Phi}_0(l_1, l_2)] P\left(\bigcap_{k=1}^2 \{C_k(t) = l_k\}\right) \end{aligned} \quad (16)$$

Table 3: Survival signature of the system in Fig.5

l_1	l_2	$\Phi(l_1, l_2)$
0	0	0
0	1	0
0	2	0
1	0	0
1	1	0
1	2	1/3
2	0	0
2	1	1/3
2	2	2/3
3	0	1
3	1	1
3	2	1

Table 4: Survival signature of the system in Fig.6

l_1	l_2	$\Phi(l_1, l_2)$
0	0	0
0	1	0
0	2	0
1	0	0
1	1	0
1	2	1/3
2	0	0
2	1	0
2	2	2/3
3	0	1
3	1	1
3	2	1

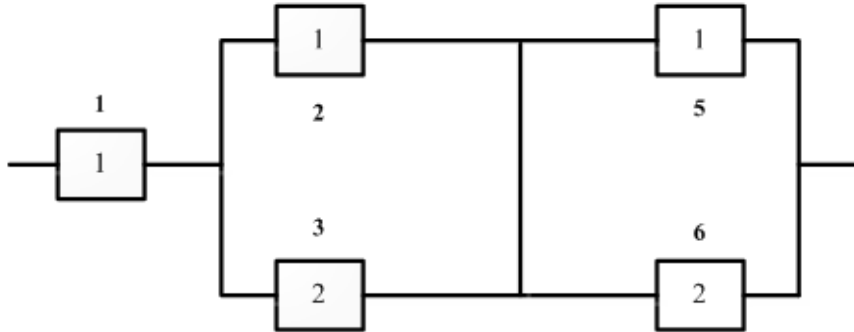

Figure 5: Component 4 works at time t .

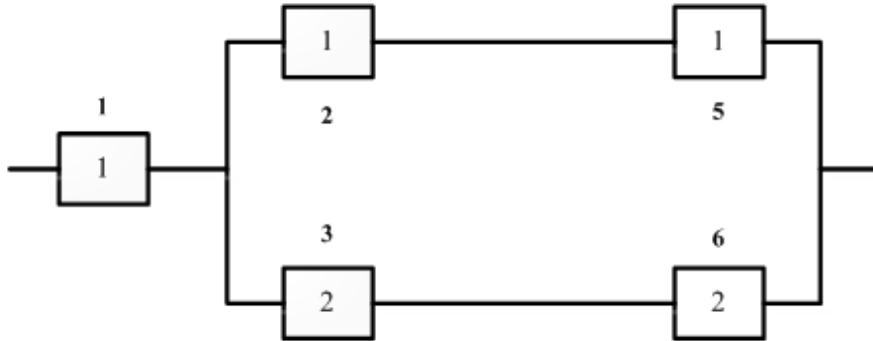

Figure 6: Component 4 fails at time t .

If the components failure times have precise distribution parameters, e.g.
 300 $\lambda_1 = 0.8$ and $\lambda_2 = 1.6$, M degenerates to a probability function $P \equiv M = \{1 - e^{-\lambda t} : \lambda_1 = 0.8; \lambda_2 = 1.6\}$. Hence, the relative importance index of component 4 can be calculated by using analytical method and the results can be seen in Fig. 7.

Considering imprecisions within components failure times, the set of all prob-
 305 ability distribution defines a probability p-box for each component failure time: $M = \{1 - e^{-\lambda t} : 0.4 \leq \lambda_1 \leq 1.2; 1.3 \leq \lambda_2 \leq 2.1\}$. Therefore, the lower and upper bounds of relative importance index of component 4 can be calculated through simulation method. Fig. 8 shows the results.

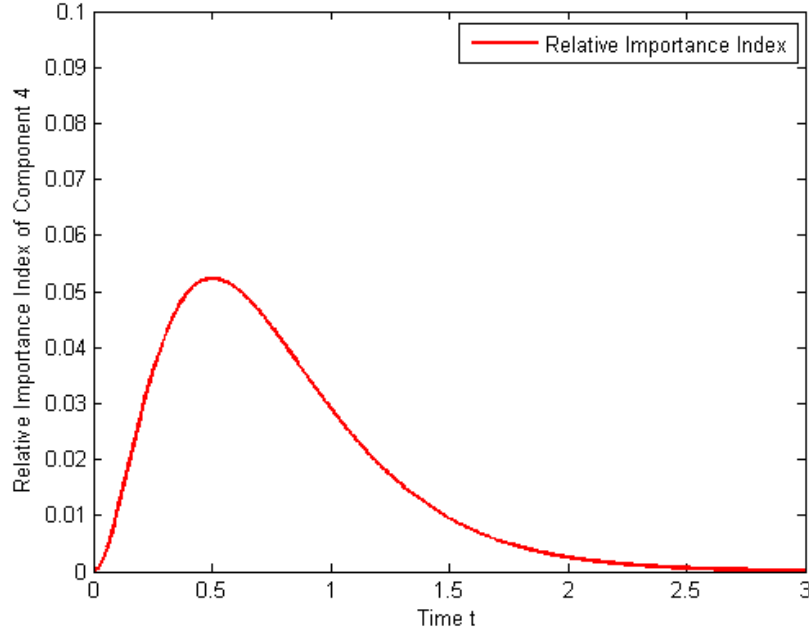

Figure 7: Relative importance index of Component 4 with precise distribution parameters.

5. NUMERICAL EXAMPLE

310 In this section, a survival analysis of a real world hydro power plant based on survival signature is conducted. The system is schematically shown in Fig. 9 and its reliability block diagram is illustrated in Fig. 10. It can be modelled as a complex system comprising the following main twelve components: (1) control gate (CG), which is built on the inside of the dam, the water from the reservoir
 315 is released and controlled through the gate; (2) two butterfly valves ($BV1, BV2$), which can transport and control the water flow; (3) two turbines ($T1, T2$), where the flowing waters kinetic energy is transformed into mechanical energy; (4) three circuit breakers ($CB1, CB2, CB3$), which are used to protect the hydro power plant system; (5) two generators ($G1, G2$), which produce alternating
 320 current by moving electrons; and (6) two transformers ($TX1, TX2$), which inside the powerhouse take the alternating current and convert it to higher-voltage

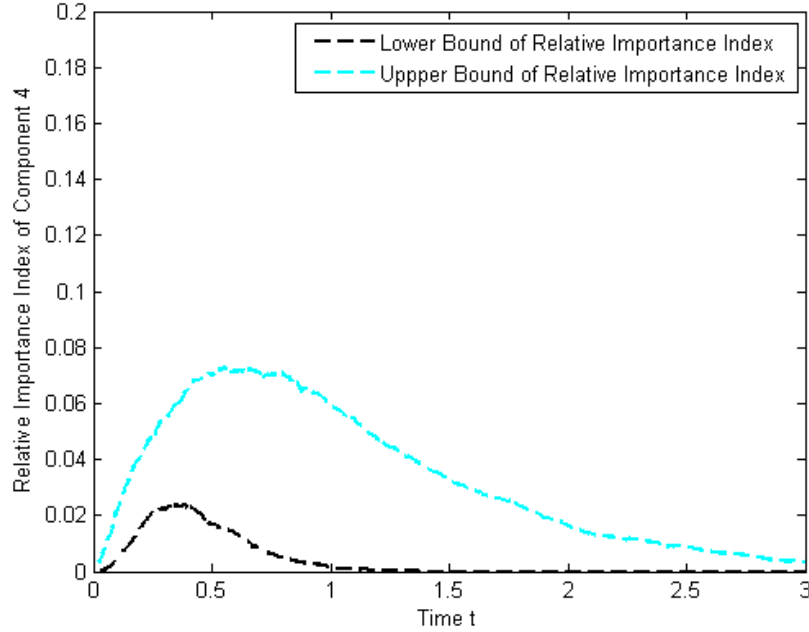

Figure 8: Relative importance index of Component 4 with imprecise distribution parameters.

current.

Two cases are presented in the following part: Case A presents the survival analysis with the fully probability model; Case B considers imprecision within
 325 the model.

5.1. Case A

It is assumed that all components of the same type have the same failure time distribution. Failure type and distribution parameters are listed in Table
 5.

330 Let l_1, l_2, l_3, l_4, l_5 and l_6 denote *CG, BV, T, G, CB* and *TX*, respectively. Table 6 shows the survival signature of the hydro power plant, whereby the rows with values $\Phi(l_1, l_2, l_3, l_4, l_5, l_6) = 0$ are omitted.

The survival signature can now be used as follows. There are $m_1 = 1, m_2 = m_3 = m_4 = m_6 = 2$ and $m_5 = 3$ components of each type. The survival signa-

Table 5: Failure types and distribution parameters of components in a hydro power plant

Component name	Distribution type	Parameters (α, β) or λ
<i>CG</i>	Weibull	(1.3,1.8)
<i>BV</i>	Weibull	(1.2,2.3)
<i>T</i>	Exponential	0.8
<i>G</i>	Weibull	(1.6,2.6)
<i>CB</i>	Gamma	(1.3,3.0)
<i>TX</i>	Gamma	(0.6,1.1)

Table 6: Survival signature of a hydro power plant in Fig.9; rows with $\Phi(l_1, l_2, l_3, l_4, l_5, l_6) = 0$ are omitted

l_1	l_2	l_3	l_4	l_5	l_6	$\Phi(l_1, l_2, l_3, l_4, l_5, l_6)$
1	1	1	1	2	[1,2]	1/12
1	1	1	2	2	[1,2]	1/6
1	1	2	1	2	[1,2]	1/6
1	2	1	1	2	[1,2]	1/6
1	1	1	1	3	[1,2]	1/4
1	1	2	2	2	[1,2]	1/3
1	2	1	2	2	[1,2]	1/3
1	2	2	1	2	[1,2]	1/3
1	1	1	2	3	[1,2]	1/2
1	1	2	1	3	[1,2]	1/2
1	2	1	1	3	[1,2]	1/2
1	2	2	2	2	[1,2]	2/3
1	1	2	2	3	[1,2]	1
1	2	1	2	3	[1,2]	1
1	2	2	[1,2]	3	[1,2]	1

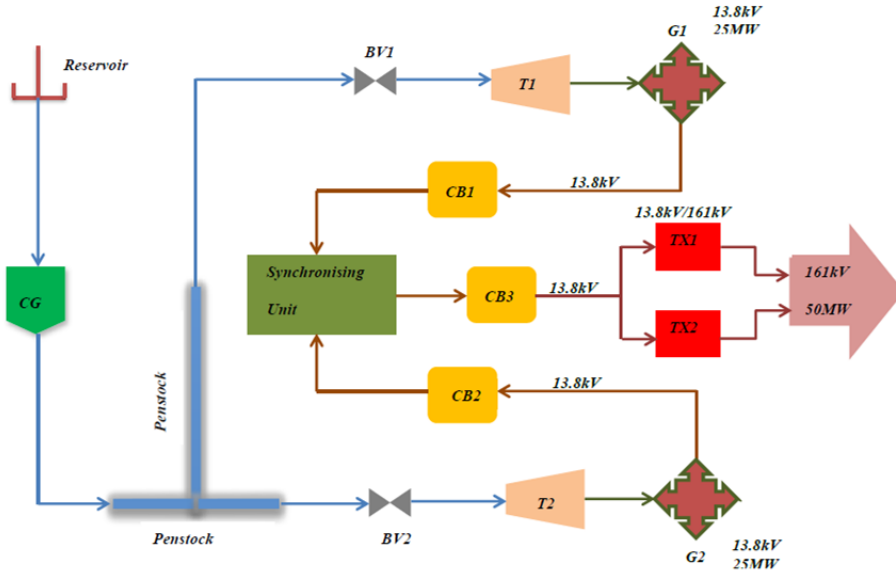

Figure 9: Schematic diagram of a hydro power plant system.

335 ture must consider combinations for all $l_1 \in \{0, 1\}$, $l_2, l_3, l_4, l_6 \in \{0, 1, 2\}$ and $l_5 \in$
 $\{0, 1, 2, 3\}$, and the state vector is $\underline{x} = (x_1^1, x_1^2, x_2^2, x_1^3, x_2^3, x_1^4, x_2^4, x_1^5, x_2^5, x_3^5, x_1^6, x_2^6)$.
 Now consider $\Phi(1, 1, 1, 2, 2, 1)$ for example. This covers all possible vectors \underline{x}
 with $x_1^1 = 1$, $x_1^2 + x_2^2 = 1$, $x_1^3 + x_2^3 = 1$, $x_1^4 + x_2^4 = 2$, $x_1^5 + x_2^5 + x_3^5 = 2$ and $x_1^6 + x_2^6 = 1$.
 There are 24 such vectors, but only four of these can make the system function.
 340 Due to the *iid* assumption of the failure times of components of the same type,
 and due to independence between components of different types, all these 24

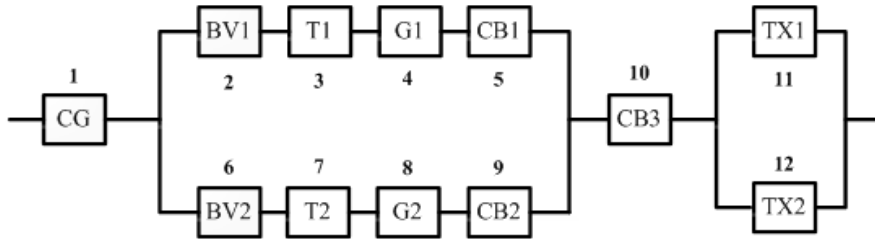

Figure 10: Reliability block diagram of a hydro power plant system.

vectors have equal probability to occur, hence $\Phi(1, 1, 1, 2, 2, 1) = 4/24 = 1/6$.

The survival function of the hydro power plant system with twelve components of six types is shown in Fig. 11.

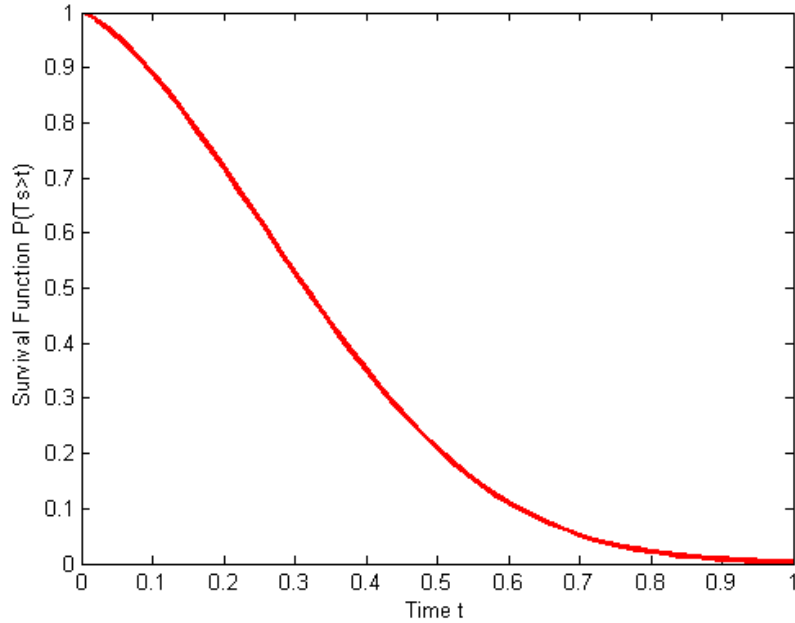

Figure 11: Survival function of a hydro power plant system along with survival functions for the individual components.

345 Based on the survival function it is possible to calculate the influence of each component on the system reliability for each point in time t . The basic theoretical knowledge and equations can be seen in Section 4, which allows to estimate of relative importance index $RI_i(t)$ of each component.

350 For the other component importance measures, analytical methods can be used to rank the component importance degree. The equations of Birnbaum's measure (BM), risk achievement worth (RAW) and Fussel-Vesely's measure (FV) to calculate the component importance $I_i(t)$ of the i th component at time t can be seen in Table 7.

In the above equations, $R_S(t)$ and $R_i(t)$ represent the reliability of the system

Table 7: Component importance equations of *BM*, *RAW* and *FV*

Methods	Component Importance Equations
<i>BM</i>	$I_i^B(t) = \frac{\partial R_S(t)}{\partial R_i(t)}$
<i>RAW</i>	$I_i^{RAW}(t) = \frac{R_S(t)(R_i(t)=1)}{R_S(t)}$
<i>FV</i>	$I_i^{FV}(t) = \frac{R_S(t) - R_S(t)(R_i(t)=0)}{R_S(t)}$

355 and the *i*th component at time *t*. For the power plant in Fig. 9, the reliability equation $R_S(t) = R_1(1 - (1 - R_2R_3R_4R_5)(1 - R_6R_7R_8R_9))R_{10}(1 - (1 - R_{11})(1 - R_{12}))$.

The component importance obtained at $t = 0.12$ using the proposed method for the power plant system have been compared with the results Birnbaum's measure (*BM*), risk achievement worth (*RAW*) and Fussel-Vesely's measure 360 (*FV*) as shown in Table 8.

Table 8: Comparison of component importance obtained using different methods at $t = 0.12$

Components	<i>CG</i>	<i>BV1</i>	<i>T1</i>	<i>G1</i>	<i>CB1</i>	<i>CB3</i>	<i>TX1</i>
Methods		<i>BV2</i>	<i>T2</i>	<i>G2</i>	<i>CB2</i>		<i>TX2</i>
<i>BM</i>	0.8854	0.1181	0.1366	0.1177	0.1191	0.8846	0.2703
ranking	1	6	4	7	5	2	3
<i>RAW</i>	7.8947	1.9280	1.9280	1.9280	1.9280	7.8947	2.5270
ranking	1	3	3	3	3	1	2
<i>FV</i>	1.000	0.1346	0.1346	0.1346	0.1346	1.000	0.2215
ranking	1	3	3	3	3	1	2
<i>RI</i>	0.8831	0.1217	0.1401	0.1213	0.1221	0.8693	0.2656
ranking	1	6	4	7	5	2	3

According to the above table, it can be drawn that *RI* method can get the same component importance ranking as Birnbaum's measure. Also, the proposed *RI* method has the same ranking trend as *RAW* and *FV*. The *RI* 365 method just needs the survival signature without calculating the reliability equation, which is useful for large systems with multiple component types.

The relative importance index values of each components over the time are shown in Fig. 12.

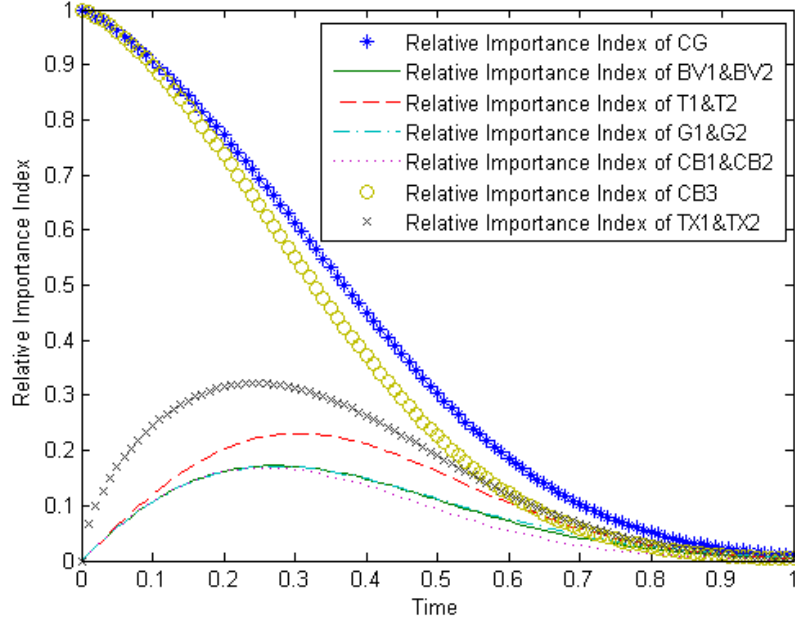

Figure 12: Relative importance index values of the system components.

The relative importance index values reveal the component importance over
 370 time. The bigger the value of $RI_i(t)$ is, the more “critical” the i th component is.
 The above results show that $BV1$ and $BV2$ have the same relative importance
 index values, and the same applies to $T1$ and $T2$, $G1$ and $G2$, $CB1$ and $CB2$,
 $TX1$ and $TX2$. This is because the components are in a parallel configuration
 and they have the same failure time distribution type and parameters, which
 375 is also according to our common sense that these components have the same
 importance degree to the system. For component $CB3$, it has same failure time
 type and distribution parameters as components $CB1$ and $CB2$, but has dif-
 ferent location in the system. Therefore, the relative importance index value
 of component $CB3$ is bigger than relative importance index values of compo-
 380 nents $CB1$ and $CB2$, but not as big as the relative importance index value of

component *CG*. Components *CG* and *CB3* have the same decreasing trend of relative importance index over time, while for the other components, the trends of relative importance index increase first, then decay with time. The relative importance index values of components *TX1* and *TX2* are always smaller than other components, which means they have smallest influence degree to the system reliability.

5.2. Case B

The investigation from CASE A is now extended by considering imprecision in the description of the probabilistic model for the failure characterization of the system components. Intervals are used to describe the imprecision in the failure time distribution as shown in Table 9.

Table 9: Failure types and distribution parameters of components in a hydro power plant

Component name	Distribution type	Parameters (α, β) or λ
<i>CG</i>	Weibull	([1.2,1.5], [1.5,2.1])
<i>BV</i>	Weibull	([1.0,1.6], [2.1,2.5])
<i>T</i>	Exponential	[0.4,1.2]
<i>G</i>	Weibull	([1.3,1.8], [2.3,2.9])
<i>CB</i>	Gamma	([1.2,1.4], [2.8,3.3])
<i>TX</i>	Gamma	([0.3,0.8], [1.0,1.3])

The upper and lower bounds of the parameters reflect the ideal and the worst case of the performance of the components, respectively. The range of the parameters represents epistemic uncertainty, which results from expert assessments of the component performance. This modelling leads to upper and lower survival functions of the hydro power plant system reflecting the epistemic uncertainties as range between the curves, see Fig. 13. The imprecision from the input is translated into imprecision of the output.

As a further step the imprecision can be carried forward to calculate ranges for the relative importance index. Firstly, ranges for the survival functions assuming given component fails or works are calculated for each component,

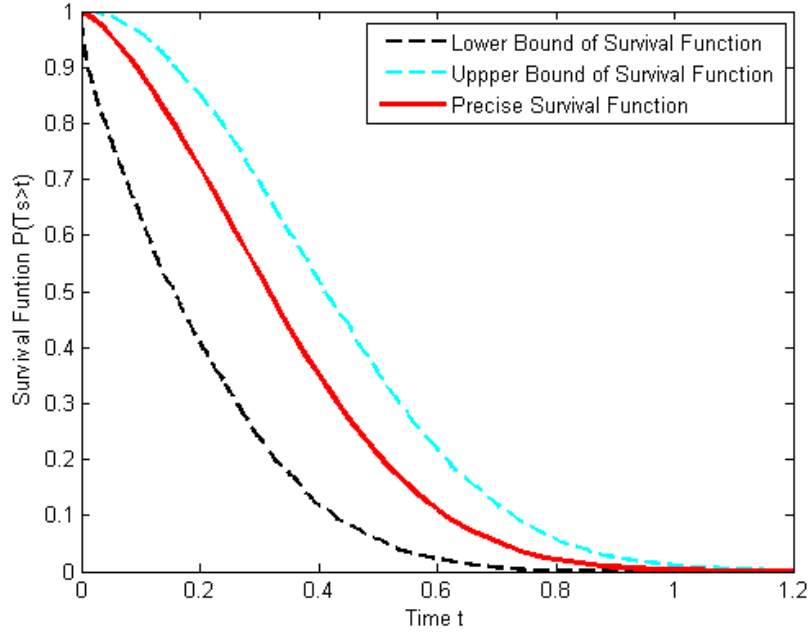

Figure 13: Upper, lower and precise survival functions of the hydro power plant system.

then the associated ranges for the relative importance index for each component are determined, see Fig. 14 and Fig. 15.

From the above figures it can be recognized that imprecision within component failure times can lead to imprecision of relative importance index of the component.

6. CONCLUSIONS

In this paper an efficient approach for analysing imprecise system reliability and component importance has been presented. The method is based on the survival signature, which has been proven to be an effective method to estimate the survival function of systems with multiple component types. In the proposed approach, the system model needs to be analysed only once in order to conduct a reliability analysis and measure a component importance, which represents a

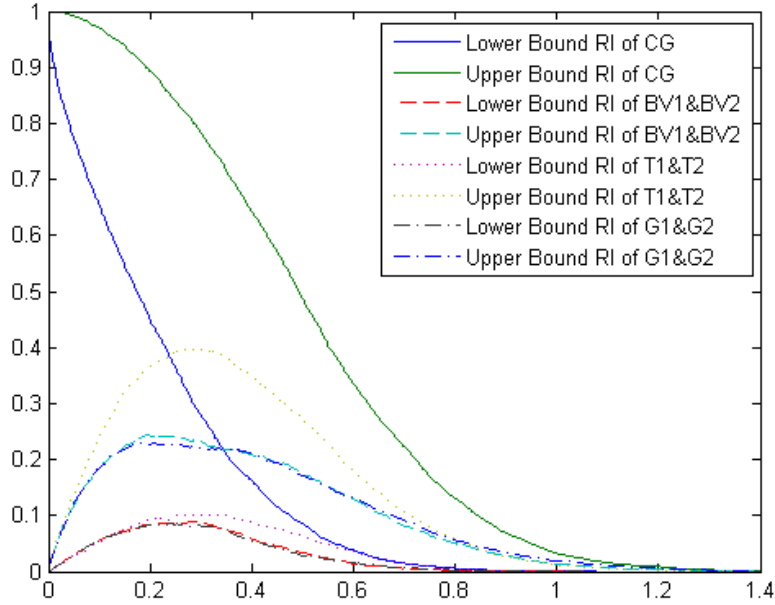

Figure 14: Upper and lower relative importance index of components CG , BV , T and G .

significant computational advantage. Performing a survival analysis on systems
 using the survival signature has been presented as a novel pathway for system
 415 reliability and component importance. In addition, the effect of imprecision,
 for example resulting from incomplete data, has been taken into account in
 the system reliability analysis and component importance measurement. As a
 consequence, bounds of survival functions of the system and intervals of relative
 420 importance index values can be obtained.

In order to quantify the influence degree of components without and with
 imprecision, a novel component-wise importance measure has been presented:
 the relative importance index. Importance measures allow to identify the most
 “critical” system component at a specific time. This allows an optimal allocation
 425 of resources for repair, maintenance and inspection. This novel and efficient
 method is conducted in an analytical way or through simulation method
 based on survival signature, which improves the computational efficiency. Using

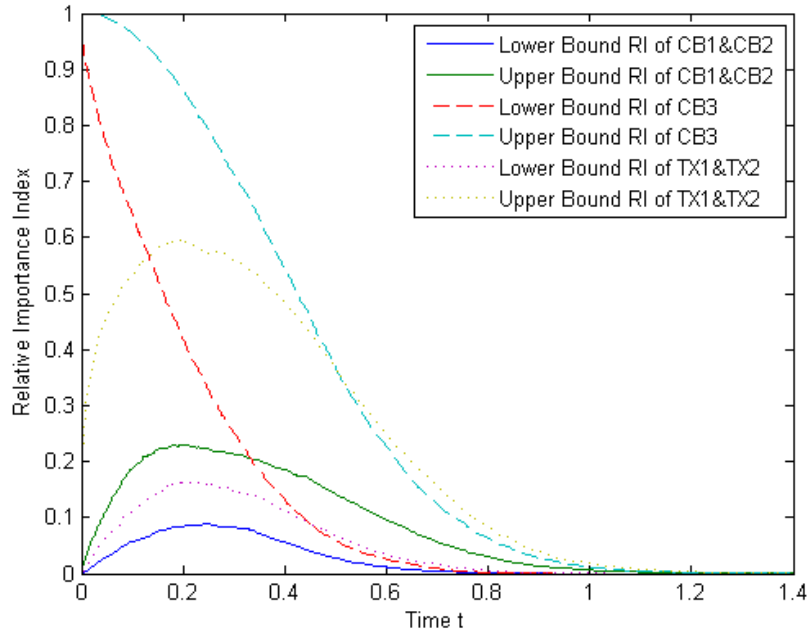

Figure 15: Upper and lower relative importance index of components CB and TX .

the relative importance index, the importance of the individual components is ranked to obtain a preference list for maintenance and repair. The effectiveness and feasibility of the proposed approaches have been demonstrated with some numerical examples. The results show that the survival signature is an efficient method to perform a reliability analysis of systems and measure components importance.

References

- [1] P. R. Adduri, R. C. Penmetsa, System reliability analysis for mixed uncertain variables, *Structural Safety* 31 (5) (2009) 375–382.
- [2] R. G. Miller Jr, *Survival analysis*, Vol. 66, John Wiley & Sons, 2011.
- [3] F. J. Samaniego, *System signatures and their applications in engineering reliability*, Vol. 110, Springer Science & Business Media, 2007.

- 440 [4] S. Eryilmaz, Review of recent advances in reliability of consecutive k-out-of-n and related systems, *Proceedings of the Institution of Mechanical Engineers, Part O: Journal of Risk and Reliability* 224 (3) (2010) 225–237.
- [5] F. P. Coolen, T. Coolen-Maturi, Generalizing the signature to systems with multiple types of components, in: *Complex Systems and Dependability*, Springer, 2012, pp. 115–130.
- 445 [6] F. P. Coolen, T. Coolen-Maturi, Modelling uncertain aspects of system dependability with survival signatures, in: *Dependability Problems of Complex Information Systems*, Springer, 2015, pp. 19–34.
- [7] L. J. Aslett, F. P. Coolen, S. P. Wilson, Bayesian inference for reliability of systems and networks using the survival signature, *Risk Analysis* 35 (3) 450 (2015) 1640–1651.
- [8] Z. W. Birnbaum, On the importance of different components in a multi-component system, Tech. rep., DTIC Document (1968).
- [9] A. Høyland, M. Rausand, *System reliability theory: models and statistical methods*, Vol. 420, John Wiley & Sons, 2009.
- 455 [10] G. Levitin, A. Lisnianski, Importance and sensitivity analysis of multi-state systems using the universal generating function method, *Reliability Engineering & System Safety* 65 (3) (1999) 271–282.
- [11] J. Fussell, How to hand-calculate system reliability and safety characteristics, *Reliability, IEEE Transactions on* 24 (3) (1975) 169–174.
- 460 [12] M. J. Armstrong, Reliability-importance and dual failure-mode components, *Reliability, IEEE Transactions on* 46 (2) (1997) 212–221.
- [13] A. Gandini, Importance and sensitivity analysis in assessing system reliability, *Reliability, IEEE Transactions on* 39 (1) (1990) 61–70.

- 465 [14] W. Wang, J. Loman, P. Vassiliou, Reliability importance of components in a complex system, in: Reliability and Maintainability, 2004 Annual Symposium-RAMS, IEEE, 2004, pp. 6–11.
- [15] E. Zio, L. Podofillini, Monte carlo simulation analysis of the effects of different system performance levels on the importance of multi-state components, Reliability Engineering & System Safety 82 (1) (2003) 63–73.
470
- [16] E. Zio, L. Podofillini, G. Levitin, Estimation of the importance measures of multi-state elements by monte carlo simulation, Reliability Engineering & System Safety 86 (3) (2004) 191–204.
- [17] M. Beer, S. Ferson, V. Kreinovich, Imprecise probabilities in engineering analyses, Mechanical systems and signal processing 37 (1) (2013) 4–29.
475
- [18] M. Beer, Y. Zhang, S. T. Quek, K. K. Phoon, Reliability analysis with scarce information: Comparing alternative approaches in a geotechnical engineering context, Structural Safety 41 (2013) 1–10.
- [19] M. Beer, V. Kreinovich, Interval or moments: which carry more information?, Soft Computing 17 (8) (2013) 1319–1327.
480
- [20] B. Möller, M. Beer, Engineering computation under uncertainty—capabilities of non-traditional models, Computers & Structures 86 (10) (2008) 1024–1041.
- [21] E. Patelli, M. Broggi, M. d. Angelis, M. Beer, Opencossan: An efficient open tool for dealing with epistemic and aleatory uncertainties, in: Vulnerability, Uncertainty, and Risk Quantification, Mitigation, and Management, ASCE, 2014, pp. 2564–2573.
485
- [22] E. Patelli, H. J. Pradlwarter, G. I. Schuëller, Global sensitivity of structural variability by random sampling, Computer Physics Communications 181 (12) (2010) 2072–2081.
490

- [23] E. Patelli, H. M. Panayirci, M. Broggi, B. Goller, P. Beaurepaire, H. J. Pradlwarter, G. I. Schuëller, General purpose software for efficient uncertainty management of large finite element models, *Finite elements in analysis and design* 51 (2012) 31–48.
- 495 [24] F. P. Coolen, T. Coolen-Maturi, A. H. Al-Nefaiee, Nonparametric predictive inference for system reliability using the survival signature, *Proceedings of the Institution of Mechanical Engineers, Part O: Journal of Risk and Reliability* 228 (5) (2014) 437–448.
- [25] S. Ferson, J. Hajagos, W. T. Tucker, Probability bounds analysis is a global
500 sensitivity analysis, in: *International Conference on Sensitivity Analysis of Model Output (SAMO)*, 2004.
- [26] S. Ferson, J. G. Hajagos, Arithmetic with uncertain numbers: rigorous and (often) best possible answers, *Reliability Engineering & System Safety* 85 (1) (2004) 135–152.
- 505 [27] S. Ferson, C. A. Joslyn, J. C. Helton, W. L. Oberkampf, K. Sentz, Summary from the epistemic uncertainty workshop: consensus amid diversity, *Reliability Engineering & System Safety* 85 (1) (2004) 355–369.
- [28] S. Ferson, V. Kreinovich, L. Ginzburg, D. S. Myers, K. Sentz, Constructing probability boxes and Dempster-Shafer structures, Vol. 835, Sandia
510 National Laboratories, 2002.
- [29] E. Wolfstetter, et al., *Stochastic dominance: theory and applications*, Humboldt-Univ., Wirtschaftswiss. Fak., 1993.
- [30] E. Zio, P. Baraldi, E. Patelli, Assessment of the availability of an offshore installation by monte carlo simulation, *International Journal of Pressure Vessels and Piping* 83 (4) (2006) 312–320.
515
- [31] J. E. Ramirez-Marquez, D. W. Coit, Composite importance measures for multi-state systems with multi-state components, *Reliability, IEEE Transactions on* 54 (3) (2005) 517–529.

- 520 [32] E. Patelli, D. A. Alvarez, M. Broggi, M. d. Angelis, Uncertainty management in multidisciplinary design of critical safety systems, *Journal of Aerospace Information Systems* 12 (1) (2014) 140–169.