

Cholinergic input to the hippocampus is not required for a model of episodic memory
in the rat, even with multiple consecutive events

Seel, S^{1,2}; Eacott M.J.^{1,2}; Langston, R.F.³; Easton A^{1,2*}

¹ Department of Psychology

Durham University

Durham, DH1 3LE

UK

² Centre for Learning and Memory Processes

Durham University

Durham, DH1 3LE

UK

³ Division of Neuroscience

University of Dundee

Dundee, DD1 9SY

UK

*Corresponding Author

Dr Alexander Easton, Dept. of Psychology, Durham University, Durham, DH1 3LE,

UK

alexander.easton@durham.ac.uk

Funding: This research did not receive any specific grant from funding agencies in the public, commercial, or not-for-profit sectors.

Abstract

Previous work has shown that depletion of the cholinergic input to the hippocampus produces no impairment in an episodic (what-where-which) memory task in rats. However, in contrast a where-which task was significantly impaired. Models of acetylcholine function related to pattern separation were used to explain this result. Recent development of spontaneous recognition tasks to assess multiple trials consecutively in the same testing session allow an opportunity to assess whether an increase in interference produces an impairment in the episodic memory task using the same cholinergic lesion. By increasing the number of trials happening consecutively the proactive interference between events being remembered increases, with the prediction that a reduction in pattern separation as a result of reduced acetylcholine in the hippocampus would now produce an impairment in this task. We show that a continual trials approach to the episodic memory task has no impact on the effects of cholinergic depletion of the hippocampus, with effects mirroring those from using just one trial a day approaches to these tasks. We suggest that pattern separation models of acetylcholine function can still explain our findings, but with an apparent emphasis on context-specific locations rather than all types of memory.

HIGHLIGHTS

- Continual trials versions of an episodic memory task are unimpaired by cholinergic lesions of the medial septum
- In contrast continual trial versions of a location-context (where-which) task are impaired in the same animals
- The results replicate the effects of lesions on one-trial a day versions of the same tasks
- Increasing the amount of interference between trials by increasing the overlap of features in consecutive events has no effect on the behavioural outcome of these lesions
- The result is interpreted in light of models of acetylcholine function centred around pattern separation

Introduction

The cholinergic system has long been implicated in memory and episodic memory in particular (Drachman, 1977). However, the evidence from manipulations of the cholinergic system in animals has been the source of a long debate as to the specific role of acetylcholine (e.g. Baxter & Chiba, 1999; Easton & Parker, 2003). In recent years, there have been specific models of the role of acetylcholine which have helped to understand a range of different findings. The 'encoding versus retrieval scheduling' (ERS) framework refers to a range of models which have aimed to explain how the hippocampus separates encoding from retrieval (Hasselmo, 1999, 2006; Meeter, Murre, & Talamini, 2004). In one approach, these models propose that high levels of acetylcholine in the hippocampus support encoding, and inhibit recurrent networks underlying pattern completion-based retrieval. In contrast, low levels would increase interference – with pattern completion allowing recollection of similar but irrelevant memories when encoding novel situations.

Being able to separate memories with significant overlap in content is critical for episodic memory. For example, one might remember the breakfast you had yesterday was the same as the breakfast you had today. The memories will contain much of the same content (what was eaten, but also likely who was present etc), may be in the same location and yet can still be separated in memory through, for example, their separation in time as one can be remembered as from today and another from yesterday. This operationalisation of episodic memory as what happened (what you ate for breakfast) where it happened and when it happened (what-where-when) has been used to determine episodic ability without relying on conscious

phenomena such as the experience of recollection in animals (Clayton & Dickinson, 1998). However, we have argued that whilst (as in the example above) time can be used to separate memories, it is sometimes difficult to observe this memory for when an event occurred in animals (Eacott & Easton, 2010; Easton & Eacott, 2008) and the temporal information can take many forms including semantic memory or as a recency judgment (Davis, Easton, Eacott, & Gigg, 2013; Eacott, Webster, & Easton, 2012) rather than being an integrated part of an episodic memory. Eacott and Norman (2004) proposed an alternative to what-where-when; what-where-which occasion. This is a similar operationalisation, except that temporal information is just one type of contextual cue that can separate one occasion from another (Eacott & Easton, 2010; Easton & Eacott, 2010; Robertson, Eacott, & Easton, 2015). I might be able to remember a breakfast I had on an occasion when the lights were out in a blackout and a breakfast I had in the warmth of the sun on a holiday as two separate occasions without remembering when they occurred (or even in which order they occurred). In this example contextual information is separating one event from the other (Robertson et al., 2015), and such implicit contextual information can determine the extent of recollection within human tasks of recognition memory (Ameen-Ali, Norman, Eacott, & Easton, 2017). However, even in this situation in which the memory of two breakfasts comes from such different occasions there is still significant overlap in the content of the memory. Again, the food eaten might be the same, the people present may be the same, the time of day will be roughly similar and yet we are able to separate these events as two clearly distinguishable occasions in our episodic memory.

In monkeys we have shown that immunotoxic lesions of the cholinergic projections to hippocampus and cortex produce a very severe memory impairment for scene learning (Easton, Ridley, Baker, & Gaffan, 2002), an episodic memory task in which monkeys learn about objects in locations against background scenes. However, we have also shown that in rats using the same immunotoxic lesion to remove the cholinergic input to the hippocampus produces no impairment in the spontaneous recognition what-where-which task of episodic memory (Easton, Fitchett, Eacott, & Baxter, 2011). However, the removal of cholinergic input to the hippocampus was not without effect in these animals; a task of where-which (where memory was demonstrated through the exploration of a location which had not previously been filled with an object in that particular context) was impaired in these same animals (Easton et al., 2011). This impairment in location-context memory (where-which) has been seen in other studies with similar cholinergic lesions of the hippocampus using learned (rather than spontaneous behaviour) tasks (Janisiewicz, Jackson, Firoz, & Baxter, 2004). We interpreted this result in terms of cholinergic impairment in pattern separation (Easton, Douchamps, Eacott, & Lever, 2012; Easton et al., 2011). In the what-where-which task, every time the animals enter the arena for either a sample or test phase there are always objects in left and right positions. Whilst the actual object changes, we proposed that a propensity to pattern complete would lead to limited confusion as there are always objects where expected (on the left and right) even though the identity of the object in that location might be a surprise. In contrast, for the where-which task the location of objects is highly unstable, moving every time the animal enters the arena. In this case, pattern completion (leading to lack of ability to discriminate this event from the similar previous events) would mean that there

would be significant confusion each time the animal enters the arena as they would expect objects where there are now none.

It remains possible, however, that the episodic memory task may be impaired in rats with cholinergic lesions of the hippocampus if there were sufficient interference between events that pattern separation became more important. Usually, spontaneous recognition memory tasks are run with just one trial a day. For the episodic memory, what-where-which, task this involves entering an arena in one context (e.g. X) with objects A and B to the left and right of the animal. It then explores the objects and the arena for two minutes. After this, the animal is picked up and removed to a holding cage whilst the arena is changed to a new context (e.g. Y) with the objects (A and B) in reversed left/right positions. The animal is then picked up and returned to the arena where again it explores for two minutes. The animal is then picked up and removed to a holding cage once again before the test session (which occurs in one of the previous contexts with two new copies of either object A or B in the left and right positions). This is the way spontaneous tasks of all kinds have been run for many years (Dix & Aggleton, 1999; Ennaceur, 2010; Ennaceur & Delacour, 1988), but there are a number of limitations to this approach. The amount of data collected each day is very low (one trial per animal) meaning many days of data collection in order to have manageable group sizes. There is also a lot of handling of the animal within a trial. In handling the animal there is likely to be some stress invoked (even very small amounts) and whilst memory is expected through exploration of novelty, there is evidence that stress produces a preference for familiar objects (neophobia) in animals (Ennaceur, 2010), meaning there is significant behavioural noise added as a result of the handling procedures. In recent

years we have adopted a new approach to spontaneous recognition memory tasks (Ameen-Ali, Eacott, & Easton, 2012; Ameen-Ali, Easton, & Eacott, 2015; Robertson et al., 2015) which overcome some of these practical limitations. In the new procedure, testing on the spontaneous recognition task occurs within an arena with a start/holding box attached to it to which the animal can return themselves at the end of a stage through a return door. This allows animals to shuttle back and forth to the arena meaning there is no handling of the animal once it has been placed in it at the start of the session. In addition, because animals are shuttling back and forth, we are able to run many trials one after another. Once the first trial has ended the animal shuttles to the holding area whilst the sample phase of the next trial is set up in the adjacent arena. Using this continual trials approach we are able to collect many more trials per animal all within a single testing session (Ameen-Ali et al., 2012). In both reducing the behavioural noise (through reduced handling) and increasing the amount of data collected from a single animal in a single session we are also able to significantly reduce the number of animals required to provide the same statistical power as the traditional one-trial a day approach (Ameen-Ali et al., 2012).

This new continual trials approach to spontaneous recognition memory tasks allows us to investigate the effect of increased interference between trials on animals with cholinergic lesions. Rather than running one-trial a day we are able to run 12 consecutive trials within a single session. Although the objects are trial unique and no two consecutive trials use the same two environmental contexts in the arena, there are only a limited of contexts available. Therefore in running 12 consecutive trials within a short (approx. 2 hours) time window there is a lot of overlap of contexts between trials, increasing the degree of interference between these trials. In this

event, one might expect pattern separation to be more important in the new continual trials approach than in the previous one trial a day approach. We therefore predict that lesions of the MS/vDB cholinergic cells, including cholinergic projections to the hippocampus, will impair episodic memory in the continual trials apparatus where the same task was unimpaired in a one-trial a day version.

Method and Materials

Subjects

10 male Lister hooded rats, which were supplied by Harlan (200-220 g upon arrival) were housed in groups of three to four in rooms maintained on a 12hr light/dark cycle (lights on from 7am to 7pm). Testing occurred during the light phase. During testing rats were food deprived to 90% of their own free-feeding body weight, but they had access to water ad libitum throughout the study. Animals started testing when they were 12 weeks old. Each animal was handled daily for three days prior to the surgery and handled again for two days before behavioural procedures started. It should be noted that animals in different surgical groups were not separated after the surgery; instead they were housed together in their cages. All experiments were performed in accordance with the U.K. Animals Scientific Procedures Act (1986) and associated guidelines.

Surgery

Each rat was assigned to one of two groups: sham (n=4) and MS/vDB lesions (n=6). Surgeries for both groups were identical and surgical procedures to produce selective lesions of cholinergic neurons in the MS/vDB followed those previously described (Baxter, Bucci, Wiley, Gorman, & Gallagher, 1995). Anaesthesia and

stereotaxic coordinates were adjusted accordingly. Rats were placed in an induction chamber charged with 4% isoflurane in 100% oxygen. They were then placed in the stereotaxic frame (Kopf Instruments, Tujunga, CA) with the head level between bregma and lambda. Isoflurane gas was delivered through a face mask attached to the stereotaxic frame. The skin was shaved and cleaned and a midline incision was made to expose the skull. Two holes were drilled in the skull at the coordinates AP +0.45mm, ML +/-0.6mm. The 23-gauge needle of a Hamilton syringe was introduced through one of the holes and lowered to a depth of DV -7.8mm. 0.3 µl of either 192 IgG-saporin (0.15 µg/ul, Advanced Targeting Systems, San Diego, CA) or sterile phosphate-buffered saline (Dulbecco's Phosphate Buffered Saline, Sigma-Aldrich, UK) was injected over a 6min time period using a microinjection pump. The needle was left in place for 6min after the injection. The needle was then raised to DV -6.2mm and another injection was made of 0.2µl of either saline or toxin at the same rate and the needle was left in place for 4min. This was done once on each side, meaning that a total of 1µl of either saline or toxin was used in each rat. When the injections were complete, the skin was closed and the rat was placed in a recovery box. All animals received 0.1ml of baytril as an antibiotic (pre-op), 0.6ml of buprenorphine (0.015 mg/ml) s.c. for analgesia and 5ml of saline and glucose solution after the surgery. Rats were returned to their home cages once they had regained normal posture and behaviour. Behavioural testing began 14 days following surgery. One rat in group sham had two holes drilled at the same position as the other animals, but was not injected with saline.

Apparatus and objects

The animals were tested in a square shaped open field and a holding area. The apparatus was 50cm² with the walls' height at 20 cm. The holding area measured 22x22x20cm (l x w x h), see Figure 1A. The features of the arena could be changed by inserting four different contexts. A door (20cm high by 10cm wide) divided the testing area from the holding area, which could be opened by the experimenter. The four contexts were as follows: context 1 – horizontal stripes & white walls, context 2 – grey lego floor and white walls with black diamond shapes, context 3 – wire mesh floor and white dot pattern walls, context 4 – white floor and horizontal stripes walls. Duplicate copies of objects made of plastic or ceramic that varied in their shape, color and height were used. Objects were never repeated across different sessions for an animal. The arena and the stimuli were cleaned between animals using disinfectant wipes (Azowipes, Vernoon-Carus Limited, Lancashire, UK). Animals were recorded throughout the training and testing. The camera was positioned above the arena to record the animals' exploratory behaviour for analysis.

Habituation and Pretraining

Each animal was handled daily for three days prior to habituation. Rats were habituated to moving between rooms (cage covers were used to minimize stress), the testing room, the open field, the objects and contexts. Behavioural testing took place in a separate room under dim, diffuse white light (25W) and white noise in the background to cover environmental noise. Pretraining involved four phases aimed to habituate the animals to the environment which lasted a total of 8 days. Phase 1 involved placing the animals in threes into the apparatus for 30 minutes in each context. This allowed them to explore the open field freely. In phase 2 animals were placed singly into the apparatus and were given 15 minutes of exploration in each

context. For phase 3 the goal was to train the animals to shuttle between the two areas of the apparatus: the testing area and the holding area. This phase consisted of four sessions (one for each context) and involved placing chow pellets (20 mg, Purified Diet; BioServ) on the floor and using the doors to control the animal's movement. In phase 4 an object was introduced and baited with pellets. The object was placed in the middle of the open field in each context and animals were given 10 minutes to explore.

Test protocol

Animals were given a single test session for each task. A testing session consisted of 12 trials. At the start of each session, the animal was placed in the holding area. The door would then open to allow the animal to move to the testing area. In both sample phases and the test phase animals were given 2 min of exploration. Between phases rats shuttled back to the holding area (for the receipt of a small food pellet which had been placed there whilst the animal was in the testing arena), where they were kept while the arena was changed. Each object on each trial was baited with a food pellet to encourage exploration, but these pellets were not used as rewards. Exploration was taken when the animal was within a distance of 1cm of the object and actively exploring it (i.e. sniffing at or touching it). Actions such as sitting on the objects or using the item as support during rearing were not considered exploratory behavior. The duration of exploration was measured off-line using bespoke stopwatch software which allowed exploration of each object to be timed manually. The testing contexts, the novel object and placement of the novel object were all counterbalanced.

object-location-context (OLC; What-where-which memory)

The new continual trial apparatus is closely modelled on the open field, which is used for a one-trial a day what-where-which testing. The apparatus consists of a testing and a holding area. A door allows the experimenter to control the movement of the animal between the two compartments. As the holding cage is attached to the open field arena, animals are trained to shuttle using pellets. After two minutes of exploration the animal is allowed to shuttle back in to the holding area and the context of the arena is changed. This process is repeated until 12 trials are completed.

In the what-where-which (see Figure 1B) animals experience two exposure phases in which objects are in the same location, but in two different contexts. In the first sample phase in context 'X', object A is on the left and object B on the right; in the second sample phase in context 'Y', object A is on the right and object B is on the left. In the test phase, animals see two copies of either object A or B in either context 'X' or 'Y'. In this example, if the test phase shows two copies of A in context X, rats will spend more time exploring the right copy of object A, because its location is mismatched with the context. In both exposure phases and the test phase animals were given 2 min of exploration

location-context (LC)

In the 'where-which' (location-context) task, rats receive two exposure phases in which they see two identical copies of an object (A and B) in different places and in different contexts (X and Y). As this task is independent of the object's identity and reflects the novelty of place-context configurations, distinct objects are used in each phase. For example, in the first exposure phase animals see two copies of object A

in the 9 o'clock and 12 o'clock position in context 'X'. In the second exposure phase animals see two copies of object B in the 12 and 3 o'clock position in context 'Y'. In the test phase, rats encounter two copies of object C at the 9 and 3 o'clock position in either context (see Figure 1C). If the test phase is configured as context 'X', the right copy of C will be explored more. This is because no item was encountered in the previous exposure phase on the right in context 'X'.

Histology

At the end of the experiment each rat was deeply anesthetized with barbiturates and transcardially perfused with 100ml saline followed by 500ml 4% paraformaldehyde in phosphate-buffered saline. Brains were postfixed in 4% paraformaldehyde and then transferred to 30% sucrose in phosphate-buffered saline. Brains were then cut into coronal sections on a freezing microtome at 48µm thickness. Sections through the MS/VDB were processed for immunohistochemistry for choline acetyltransferase. Characterisation of the lesion is shown in Figure 2.

Results

Histology

Sections from animals in Groups Sham and MS/vDB are shown in Fig. 2. Cell counts were taken for those cells stained for choline acetyltransferase in both target regions (MS and vDB bilaterally) and non-target regions (hDB). Group MS/vDB showed a reduction in cells in the MS (mean Group Sham = 50.8; mean group MS/vDB = 28.3) and the vDB (mean Group Sham = 55.0; mean Group MS/vDB = 28.0) but no reduction in cell count in hDB (mean Group Sham = 49.0; mean Group MS/vDB = 51.2).

Behavioural measures

Memory was measured through a discrimination ratio (D2) calculated as the (exploration of the novel configuration – exploration of the familiar configuration)/total exploration. This gives a score of between -1 and 1 where 0 reflects chance performance, 1 reflects exploration of only the novel configuration and -1 reflects exploration of only the familiar configuration. In calculating the discrimination ratio for 12 consecutive trials there are two possible methods. First the *average D2* can be derived by calculating the D2 for each individual trial and then averaging these to achieve a single D2 for the overall performance. In contrast the *cumulative D2* can be calculated by summing the total exploration of novel and familiar configurations over all 12 trials and then calculating a single discrimination ratio from these total explorations. Whilst average D2s (which give equal weighting to each trial) are

typical in one-trial a day tasks, cumulative D2s (which give less significance to trials with small amounts of exploration) have been used when multiple trials are run in a single session (Albasser et al., 2010; Ameen-Ali et al., 2012). We typically report both measures here to allow the maximum comparison with previous literature. All measures reported are one-tailed.

Object-location-context (OLC) task

Both group Sham and group MS/vDB performed above chance on this task, showing evidence of episodic-like memory, See Figure 3A and 3B. For both groups the average D2 scores were significantly above chance [Group Sham mean=0.13; $t(3)=6.947$, $p=0.003$; Group MS/vDB mean=0.14; $t(5)=4.372$, $p=0.004$]. The groups did not significantly differ from one another [$t(8)<1$]. For cumulative D2s Group Sham approached significance [mean=0.133; $t(3)=2.110$, $p=0.06$] and Group MS/vDB were significantly above chance [mean=0.214; $t(5)=3.297$, $p=0.01$]. Once again, there was no significant difference between the groups [$t(8)<1$].

In order to understand the effects of interference resulting from continual trials a repeated-measures ANOVA was carried out to compare the averaged D2 from the first block of two trials (where interference was lowest) with the averaged D2 from the final block of two trials (where interference was greatest) for each group, see Figure 3C. The ANOVA showed no main effect of group [$F(1,8)<1$] or of block [$F(1,8)=3.10$, $p=0.116$] and no interaction between the two [$F(1,8)=1.54$, $p=0.25$]. In addition, the final block of two trials was itself significantly above chance for both

Group Sham [mean=0.29; $t(3)=3.27$, $p=0.03$] and Group MS/vDB [mean=0.16; $t(5)=4.127$, $p=0.005$].

Location-context (LC) task

For cumulative D2 scores Group Sham was significantly above chance [mean=0.19, $t(3)=2.489$, $p=0.045$] but Group MS/vDB were not [mean=0.03, $t(3)<1$] suggesting a difference in performance on this task between the two groups (see Figure 4). For the averaged D2s both Group Sham [mean=0.16, $t(3)=2.361$, $p=0.05$] and Group MS/vDB [mean=0.07, $t(3)=3.634$, $p=0.008$] were above chance, and on neither measure was the performance of each group significantly different from one another [averaged D2s $t(8)=1.529$, $p=0.17$; cumulative D2s $t(8)=1.88$, $p=0.1$]

Repeat of OLC

To ensure that the LC result does not reflect a developing lesion over time, the animals were retested on the OLC task. Group Sham were significantly above chance on both D2 measures [averaged D2 mean=0.14, $t(3)=5.737$, $p=0.005$; cumulative D2 mean=0.15, $t(3)=7.377$, $p=0.003$]. Group MS/vDB were also significantly above chance on both D2 measures [averaged D2 mean=0.12, $t(5)=3.57$, $p=0.008$; cumulative D2 mean =0.18, $t(5)=2.985$, $p=0.016$], see Figure 5. The groups did not significantly differ from each other on either measure [$t(8)<1$ for both D2 measures].

Discussion

The results of the present study mostly replicate our earlier findings using the same tasks but a one-trial a day approach (Easton et al., 2011). Here using continual trial versions of these tasks we find that cholinergic immunotoxic lesions of the MS/vDB do not impair the episodic what-where-which (OLC) task at any point. In contrast the where-which (LC) task is impaired by the same lesion (using cumulative D2 measures, although not using averaged D2 measures).

Although one trial a day versions of spontaneous recognition tasks typically average the D2s from each trial by each animal, continual trial approaches have adopted the method of a cumulative D2 derived from the total exploration of novel and familiar items over all trials in a single session (Albasser et al., 2010; Ameen-Ali et al., 2012). This approach stems from work of Albasser et al (2010) who used this same cumulative score in their bow-tie maze for object recognition. Each of these different approaches has advantages and disadvantages in this continual trials apparatus. Using the averaged D2 provides an overall D2 for the animal in which every trial has the same weighting as every other trial. In a one trial a day spontaneous recognition task this has the advantage of ensuring that individual variation between trials is balanced out. For example, if on a particular day (one trial in a standard task) there is some noise, odour or distraction to the animal which biases it towards (or away from) a particular object then this carries no more weight in the overall performance of the animal than any other trial, even though exploration times may have been much greater. It is a way of ensuring when trials are run over many days that there is no systematic bias from trials which are affected by extraneous events. In contrast, in the continual trials apparatus all trials happen within the same day, and in this

case within the same 2-3 hour period. Alongside the effects of lack of handling between trials, this means that we would expect each and every trial to be much more similar to each other in terms of conditions affecting the trial (other than memory). Therefore there is less need to ensure that no trial has an added weight and more reason to assume that a single testing session with many trials can be viewed as similar conditions, allowing performance to be summed across those trials to give a cumulative D2. However, whilst we may not expect the cumulative D2 to be affected by extraneous events on individual trials, it is possible that the cumulative D2 is sensitive to effects such as interference or habituation to procedure. If the animal habituates to the task over several trials then exploration time may drop on later trials, meaning those trials have a reduced weighting in the overall performance. This might not be problematic given they will reflect trials on which there are small amounts of exploration. In contrast, averaged D2s might not give appropriate weighting on the basis of exploration in the same situation. If exploration goes down to very small levels in later trials then an averaged D2 will continue to give equal weight to each of these trials, even though the implications of small differences may only be noticeable over many trials. As a direct result of these differences in what the averaged and cumulative D2s measure, we suggest that tests using the continual trials approach to spontaneous recognition tasks routinely report both forms of D2 as any differences between them (as here on the LC task) might prove meaningful in terms of interpreting the results.

The results of the episodic task (what-where-which; OLC) show that just as for the one trial a day version of the same task, performance is not affected by depletion of the cholinergic input to the hippocampus, even though the task itself is dependent on

normal hippocampal function (Eacott & Easton, 2007; Eacott & Norman, 2004; Langston & Wood, 2010). The current task in the continual trials apparatus introduces much more interference between conditions when compared to the standard one-trial a day task. On each trial there are two contexts used, and there are only five contexts available meaning in every block of 3 trials at least two contexts will be re-used. This means that over the 12 trials in a single testing session there are a lot of events occurring in contexts (and even context pairings) that have been seen recently. Where context is used to provide an identifier for the occasion to be remembered (Eacott & Easton, 2010) this means that there will be more confusion (interference) between events occurring in the same context. Whilst some theories of cholinergic function propose that the cholinergic system is required to ensure good pattern separation (allowing better separation in memory of events which share many common features; (Hasselmo, 1999, 2006) we see no evidence here of increasing involvement of the cholinergic system when interference increases in this manner. The lack of impairment is not just a result of an ineffective lesion as the same animals are impaired at the LC task, and remain unimpaired when re-tested on the OLC task afterwards.

In contrast to the lack of impairment in the episodic OLC task, animals with cholinergic immunotoxic lesions of the MS/vDB show impairment in the where-which (LC) task. Here impairment was only seen on the measure of cumulative D2, but not averaged D2. As discussed above, there are several differences in the behaviour captured by each version of this measure. By convention continual trials tasks use cumulative D2s on the assumption that the entire testing session can be considered similar enough for exploration to be summed across trials.

That an impairment is seen at all in the LC task where one is not observed in the OLC task mirrors that from one-trial a day versions of these same tasks (Easton et al., 2011). Given the impairment is seen only in cumulative D2s, it seems unlikely that the added interference from multiple consecutive trials with overlapping contexts (as for the OLC task) have made this task more difficult for the animals with the cholinergic lesion. Once again, then, it seems that increasing interference from consecutive trials requires no additional involvement from the cholinergic input to the hippocampus in order to be overcome. Rather, we believe that this current data supports the finding from our earlier work that it is the nature of the spatial information in the task which is critical for cholinergic involvement. In the OLC task objects always appear on the left and right positions as the animal enters (given that it always enters from the same direction; ie from the start arm). Increased pattern completion in the absence of cholinergic input might mean the animal cannot easily predict which objects will be in which positions, but it will find objects in known fixed positions and recognition processes will allow it to identify the objects once seen. In contrast, for the LC task the locations of objects on every sample, and test, change (there are 3 locations used for which two are filled on any given occasion). In this case then objects may not be where expected, leading to confusion and impaired memory.

This explanation might also explain why the impairment in the LC task is less clear in the continual trials task than it was in the one-trial a day task. In the continual trials approach the same three locations are filled over the course of a trial, and every trial reuses the same three locations. It is possible that just like animals can expect

objects in fixed trials in the episodic OLC task, having consecutive trials allows animals to build up an expectation of three locations in the LC task and become less confused over the course of the test session. Pattern completion may well continue to impair performance, but not as much as when filled locations of objects are harder to predict (as they may be when offered for just one trial a day).

It remains possible that the lack of impairment in the episodic OLC task also reflects a difference in the types of spatial information being used in the OLC and LC tasks. Animals always enter the testing arena from the door, meaning in the OLC task they are always orientated with the objects on their left and right at entry. This might allow egocentric spatial solutions to the task which are not hippocampal dependent. For example, Langston and Wood (2010) have shown the hippocampus to be crucial for object-location memory when animals use allocentric, but not egocentric strategies. In contrast, in the LC task whilst animals enter through the same door on every trial, the objects move in relation to their entry point, i.e. they are not always to the left and right of the animal. This may require an allocentric spatial strategy which relies on the hippocampus. However, the OLC task is impaired following hippocampal lesions (Eacott & Easton, 2007; Eacott & Norman, 2004; Langston & Wood, 2010), so any such explanation would have to rely not on the lack of involvement of the hippocampus in such an egocentric strategy, but rather on the lack of involvement of cholinergic input to the hippocampus in such a strategy. In addition, whilst spacing of objects was standardised as much as possible across the OLC and LC tasks, it is possible that in the OLC task different distances between objects might underlie the difference in performance on the two tasks. We know that the hippocampus is involved in the discrimination of different distances (e.g. Gilbert, Kesner, &

DeCoteau, 1998). Whilst we have, therefore, interpreted the results in relation to the pattern completion of similar events, it is possible that spatial memory components of the two tasks differ and are differently affected by removal of the cholinergic inputs to the hippocampus. Development of novel versions of the OLC and LC tasks which share spatial configurations would be required to distinguish these different possibilities.

Overall, the results of the current study support the findings of Easton et al (2011) in showing the cholinergic input to the hippocampus is not required for episodic memory in the rat, and that pattern completion effects may underlie the dissociation of the OLC and LC tasks. Here we show that pattern completion effect is only likely to underlie performance when interference between occasions is limited to unpredictable locations, and not to increased interference through, for example, context overlap between consecutive trials. Although supporting the findings of our earlier work in rats, this finding does contradict earlier studies of cholinergic immunotoxic lesions in primates which showed impairment in an episodic task in which animals learnt about object in particular locations against particular background contexts (Easton et al., 2002). There remain many differences between primate and rodent cholinergic systems (Easton & Parker, 2003) and there are likely also to be differences in the way in which the objects on a screen are represented in the monkey task compared to objects in a 3D environment in which a rat moves around. In addition, the spatial differences between the tasks here in the rat may differentiate these results from those in primates. Nonetheless the results of the current study show that increased feature overlap per se is not enough to explain the results, but rather that predictable positions seem critical in overcoming the effects of

cholinergic depletion of the hippocampus. It is notable that in the monkey task the locations of objects were not predictable for the animals, being trial unique and with very many trials occurring over the weeks of testing. We believe that this focus on the spatial aspects of the task will allow a better understanding of the cholinergic system in memory.

REFERENCES

- Albasser, M. M., Chapman, R. J., Amin, E., Iordanova, M. D., Vann, S. D., & Aggleton, J. P. (2010). New behavioral protocols to extend our knowledge of rodent object recognition memory. *Learning & Memory, 17*(8), 407-419. doi: Doi 10.1101/Lm.1879610
- Ameen-Ali, K. E., Eacott, M. J., & Easton, A. (2012). A new behavioural apparatus to reduce animal numbers in multiple types of spontaneous object recognition paradigms in rats. *Journal of Neuroscience Methods, 211*, 66-76.
- Ameen-Ali, K. E., Easton, A., & Eacott, M. J. (2015). Moving beyond standard procedures to assess spontaneous recognition memory. *Neuroscience and Biobehavioral Reviews, 53*, 37-51.
- Ameen-Ali, K. E., Norman, L. J., Eacott, M. J., & Easton, A. (2017). Incidental context information increases recollection. *Learning and Memory, 24*, 136-139.
- Baxter, M. G., Bucci, D. J., Wiley, R. G., Gorman, L. K., & Gallagher, M. (1995). Selective Immunotoxic Lesions of Basal Forebrain Cholinergic Cells - Effects on Learning and Memory in Rats. *Behavioral Neuroscience, 109*(4), 714-722.
- Baxter, M. G., & Chiba, A. (1999). Cognitive functions of the basal forebrain. *Current opinion in neurobiology, 9*, 178-183.
- Clayton, N. S., & Dickinson, A. (1998). Episodic-like memory during cache recovery by scrub jays. *Nature, 395*, 272-274.
- Davis, K. E., Easton, A., Eacott, M. J., & Gigg, J. (2013). Episodic-Like Memory for What-Where-Which Occasion is Selectively Impaired in the 3xTgAD Mouse Model of Alzheimer's Disease. *Journal of Alzheimers Disease, 33*(3), 681-698. doi: 10.3233/jad-2012-121543
- Dix, S., & Aggleton, J. P. (1999). Extending the spontaneous preference test of recognition: evidence of object-location and object-context recognition. *Behavioural brain research, 99*(2), 191-200.
- Drachman, D. A. (1977). Memory and cognitive function in man - does cholinergic system have a specific role. *Neurology, 27*(8), 783-790.
- Eacott, M. J., & Easton, A. (2007). On familiarity and recall of events by rats. *Hippocampus, 17*, 890-897.
- Eacott, M. J., & Easton, A. (2010). Episodic memory in animals: remembering which occasion. *Neuropsychologia, 48*, 2273-2280.
- Eacott, M. J., & Norman, G. (2004). Integrated memory for object, place, and context in rats: a possible model of episodic-like memory? *The Journal of Neuroscience, 24*(8), 1948-1953.
- Eacott, M. J., Webster, L. A. D., & Easton, A. (2012). The episodic nature of episodic-like memories. *Learning & Memory, 19*, 146-150.
- Easton, A., Douchamps, V., Eacott, M. J., & Lever, C. (2012). A specific role for septohippocampal acetylcholine in memory? *Neuropsychologia, 50*, 3156-3168.
- Easton, A., & Eacott, M. J. (2008). A new working definition of episodic memory: replacing 'when' with 'which'. In E. Dere, A. Easton, L. Nadel & J. P. Huston (Eds.), *Handbook of episodic memory* (Vol. 18, pp. 185-196). Amsterdam: Elsevier.
- Easton, A., & Eacott, M. J. (2010). Recollection of episodic memory within the medial temporal lobe: Behavioural dissociations from other types of memory. *Behavioural Brain Research, 215*, 310-317.
- Easton, A., Fitchett, A., Eacott, M. J., & Baxter, M. G. (2011). Medial Septal cholinergic neurons are necessary for context-place memory but not episodic-like memory. *Hippocampus, 21*, 1021-1027.
- Easton, A., & Parker, A. (2003). A cholinergic explanation of dense amnesia. *Cortex, 39*, 813-826.
- Easton, A., Ridley, R. M., Baker, H. F., & Gaffan, D. (2002). Lesions of the cholinergic basal forebrain and fornix in one hemisphere and inferior temporal cortex in the opposite hemisphere produce severe learning impairments in rhesus monkeys. *Cerebral Cortex, 12*, 729-736.

- Ennaceur, A. (2010). One-trial object recognition in rats and mice: Methodological and theoretical issues. *Behavioural brain research*, 215(2), 244-254. doi: 10.1016/j.bbr.2009.12.036
- Ennaceur, A., & Delacour, J. (1988). A new one-trial test for neurobiological studies of memory in rats. 1: Behavioral data. . *Behavioural brain research*, 31, 47-59.
- Gilbert, P. E., Kesner, R. P., & DeCoteau, W. E. (1998). Memory for spatial location: role of the hippocampus in mediating spatial pattern separation. *Journal of Neuroscience*, 18, 804-810.
- Hasselmo, M. E. (1999). Neuromodulation: acetylcholine and memory consolidation. *Trends in cognitive sciences*, 3(9), 351-359. doi: citeulike-article-id:4132068
- Hasselmo, M. E. (2006). The role of acetylcholine in learning and memory. *Current opinion in neurobiology*, 16(6), 710-715. doi: 10.1016/j.conb.2006.09.002
- Janisiewicz, A. M., Jackson, O., Firoz, E. F., & Baxter, M. G. (2004). Environment-spatial conditional learning in rats with selective lesions of medial septal cholinergic neurons. *Hippocampus*, 14(2), 265-273. doi: 10.1002/hipo.10175
- Langston, R., & Wood, E. (2010). Associative recognition and the hippocampus: Differential effects of hippocampal lesions on object-place, object-context and object-place-context memory. *Hippocampus*, 20, 1139-1153.
- Meeter, M., Murre, J. M. J., & Talamini, L. M. (2004). Mode shifting between storage and recall based on novelty detection in oscillating hippocampal circuits. *Hippocampus*, 14(6), 722-741. doi: Doi 10.1002/Hipo.10214
- Robertson, B. A., Eacott, M. J., & Easton, A. (2015). Putting memory in context: Dissociating memories by distinguishing the nature of context. *Behavioural brain research*, 285, 99-104.

FIGURE LEGENDS

Figure 1

Depiction of continual trials apparatus and tasks. A) The continual trials apparatus consisted of a 50cmx50cm test area (TA) and a 22cmx22cm holding area (H) attached to it with a removable sliding door separating the two. Animals were first placed in the holding area before the door was opened to allow them to enter the testing area. All samples and tests were carried out in the test area, where different contexts could be provided through the use of inserts which fitted into this arena. B) The episodic memory (what-where-which; OLC) task. The procedure for a single trial is depicted with events running from left to right. Objects are represented by letters and contexts by shading within the test area. Arrows show the direction of movement of the animal at any stage. To begin the door between the holding area and test area opens and the animal moves into the test area where it encounters two objects to the left and right of the arena (from the animal's perspective). After 2 minutes exploring this the animal returns through the re-opened doorway into the holding area (second panel). A two minute delay allows the experimenter to insert a new context into the test area and rearrange the objects to their new configuration before the animal enters for a further 2 min exploratory phase (panel 3). At the end of this period the animal returns once more to the holding area (panel 4) and the experimenter sets up the test in which two new copies of one of the objects (in this case A) are presented in the left/right positions in one of the previously seen contexts. At test (right hand panel) the animal re-enters the test area and explores the objects once more for a further 2 minutes. In this case object A (what) has not been seen on the right (where) in this context (which) meaning preferential exploration of that object reflects what-

where-which (OLC) memory. The figure represents a single trial. A second trial would begin once the animal returned to the holding area, and would use new (trial unique) objects. Five contexts were available with 2 being used on any given trial and no context being used on two consecutive trials. C) The where-which (LC) task. Again, panels from left to right show the movement of animals through the apparatus from phase to phase of one trial. Animals first enter the test area (left hand panel) with two copies of an object in 9 o'clock and 12 o'clock positions, before returning to the holding area after 2 minutes. In the second sample (middle panel) the animal returns to the test area (in which a new context insert has now been placed) and has a further 2 minutes to explore two copies of a new object (B) in the 12 o'clock and 3 o'clock positions before returning to the holding area. At test (right hand panel) the animal returns to one of the previously seen contexts and has two minutes to explore two copies of a further new object (C) in the 9 o'clock and 3 o'clock positions. In this case object C in the 3 o'clock position fills a place (location) which has not been filled previously in that context (context) meaning preferential exploration of this object shows LC memory. The figure represents a single trial. A second trial would begin once the animal returned to the holding area, and would use new (trial unique) objects. Five contexts were available with 2 being used on any given trial and no context being used on two consecutive trials.

Figure 2

Immunostained sections from the medial septum (MS) in an animal from Group Sham (left hand panel) and an animal from Group MS/vDB (right hand panel). The animal from Group Sham shows dark stained cells throughout the MS whilst these

same cells are almost entirely absent at the same level in the animal from Group MS/vDB.

Figure 3

First experience of the episodic (OLC) task. All error bars represent the SEM. A) shows cumulative D2 over the course of 12 trials. Solid line represents performance of animals in Group Sham, dotted line represents performance of animals in Group MS/vDB. Each trial represents the D2 on that trial calculated from all exploratory performance on all trials up to that point. Final performance is calculated at the final trial (trial 12) which shows performance significantly above chance in both groups. B) shows averaged D2 for each group over the 12 trials, calculated by averaging the D2 from each of the 12 trials for each animal. White bar reflects performance of Group Sham. The hatched bar reflects performance of Group MS/vDB. Both groups perform significantly better than chance, and are not significantly different from each other. C) Comparison of performance of Group Sham (white bar) and Group MS/vDB (hatched bar) averaged over the first and last two trials to examine the effects of interference. Performance is above chance for both groups in the final two trials, but not for either group in the first two trials. There are no significant differences between the groups, or interactions of group and first or last trials.

Figure 4

Where-which (LC) task. All error bars represent the SEM. A) shows cumulative D2 over the course of 12 trials, showing a difference in performance between the two groups. Solid line represents performance of animals in Group Sham, dotted line represents performance of animals in Group MS/vDB. Each trial represents the D2

on that trial calculated from all exploratory performance on all trials up to that point. Final performance is calculated at the final trial (trial 12) which shows performance significantly above chance for Group Sham, but not Group MS/vDB. B) shows averaged D2 for each group over the 12 trials, calculated by averaging the D2 from each of the 12 trials for each animal. White bar reflects performance of Group Sham. The hatched bar reflects performance of Group MS/vDB. Both groups perform significantly better than chance, and are not significantly different from each other.

Figure 5

Second experience of the episodic (www; OLC task). All error bars represent the SEM. A) shows cumulative D2 over the course of 12 trials. Solid line represents performance of animals in Group Sham, dotted line represents performance of animals in Group MS/vDB. Each trial represents the D2 on that trial calculated from all exploratory performance on all trials up to that point. Final performance is calculated at the final trial (trial 12) which shows performance significantly above chance for both groups. B) shows averaged D2 for each group over the 12 trials, calculated by averaging the D2 from each of the 12 trials for each animal. White bar reflects performance of Group Sham. The hatched bar reflects performance of Group MS/vDB. Both groups perform significantly better than chance, and are not significantly different from each other.

FIGURE 1

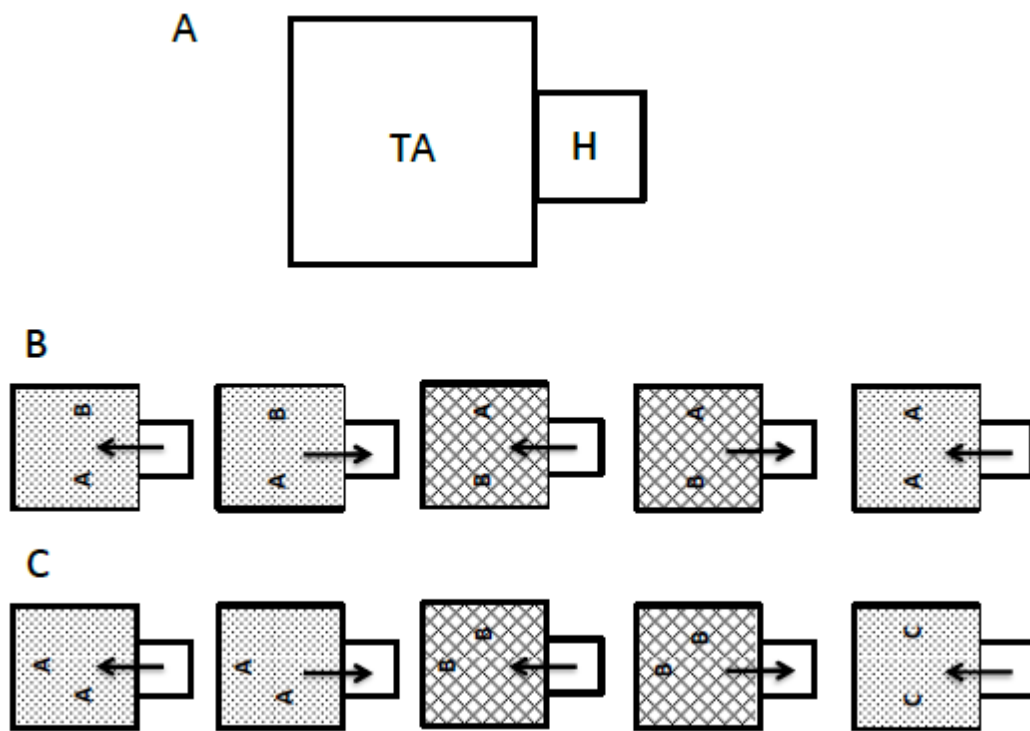

FIGURE 2

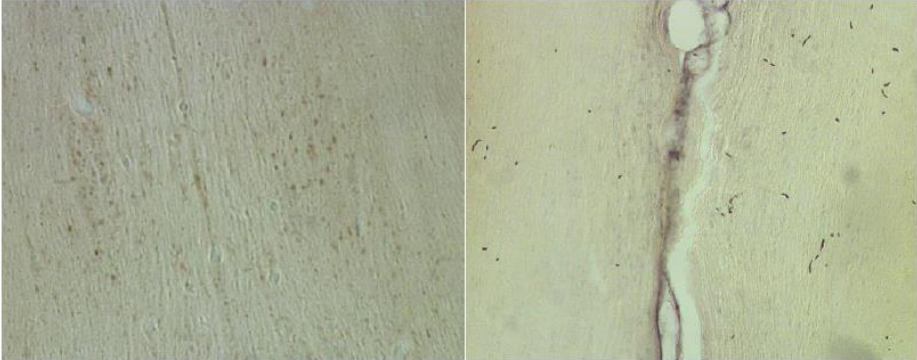

FIGURE 3

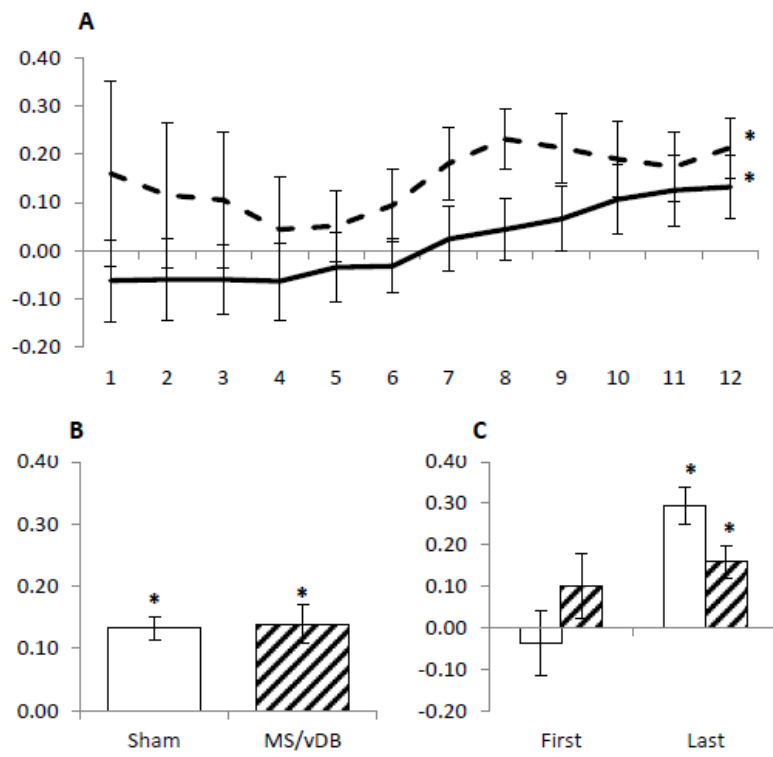

FIGURE 4

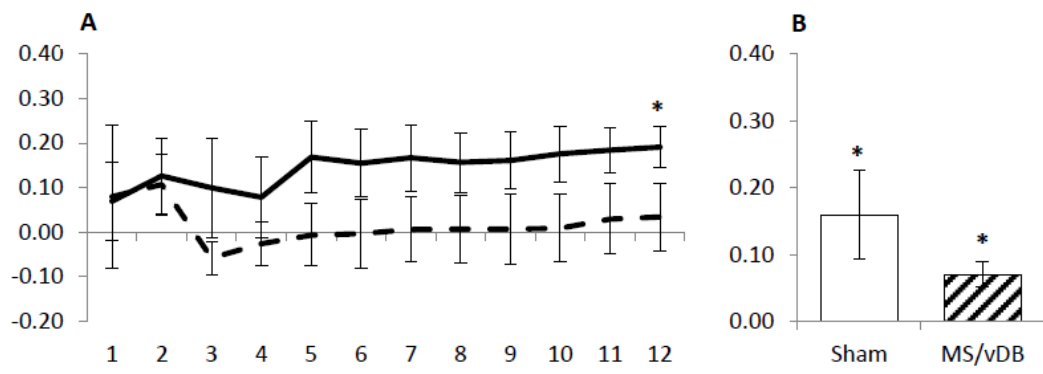

FIGURE 5

