



The role of innovation in advancing understanding of hydrological processes

Louise J. Bracken¹ | Ladan Cockshut¹ | Jenny Taylor² | Sarah Cotterill³

¹Department of Geography,
Durham University, Durham, UK

²Research and Innovation Services,
Durham University, Durham, UK

³School of Civil Engineering,
University College Dublin, Dublin, Ireland

Correspondence

Louise J. Bracken, Department of Geography,
Durham University, Durham DH1 3LE, UK.
Email: l.j.bracken@durham.ac.uk

Abstract

Innovation and understanding hydrological processes are intimately linked. Existing research has demonstrated the role of technological, societal, and political drivers in shaping and delivering new understandings in hydrological processes. In this paper we pose three research questions to explore how innovation can further our understanding of hydrological processes, if working towards the sustainable development goals (SDGs) provides a helpful focus, and whether specific mechanisms can be used to facilitate innovation and research into hydrological processes. First, we examine key aspects of innovation and explore innovation in the context of water security. We then present a series of innovation projects to determine their effectiveness in delivering innovation in managing hydrological processes, but also their contribution to scientific understanding. Our research suggests that product and process innovation were more closely related to increasing scientific understanding of hydrological processes than other forms of innovation. The NE Water Hub demonstrated that the design of the innovation ecosystem was crucial to its success and provides a model to integrate innovation and research more widely to further scientific understanding and deliver behaviour change to address the SDGs.

1 | INTRODUCTION

Innovation and understanding of hydrological processes are intimately linked. Innovation is defined as the use of a new idea, which might include creative thoughts, new devices or new methods. Innovation in hydrological processes has frequently been viewed as developments in sensing systems, adoption of multidisciplinary perspectives in tackling earth observation, or opportunistic use of measurements and developments in computing power (Tauro et al., 2018). This view is founded on the notion that technological developments bring new understanding of hydrological processes. Research has also embraced approaches such as citizen science and participatory research that

encourages the use of less traditional forms of data collection and recognizes alternative sources of knowledge (e.g., Rollason, Bracken, Hardy, & Large, 2018; Watson & Howe, 2006).

Research has also demonstrated how the progress of hydrological science has been brought about by the integration of technical opportunities with societal needs (Sivapalan & Blöschl, 2017). In this alternative view the driver delivered by societal needs has provided the context for developing new knowledge but has also given an opportunity for application of new understandings in hydrological processes. Sivapalan and Blöschl (2017) proposed six eras of research in which the interaction of new technologies, new ideas and changing societal needs has played out to deliver a step change in understanding

This is an open access article under the terms of the Creative Commons Attribution License, which permits use, distribution and reproduction in any medium, provided the original work is properly cited.

© 2020 The Authors. *Hydrological Processes* published by John Wiley & Sons Ltd.

TABLE 1 Eras of understanding in hydrological processes proposed by Sivapalan and Blöschl (2017)

Era	Societal driver	Time period	Technical opportunities
Empirical	Flood design	1910–1930	National networks
Rationalization	Land management	1930–1950	Experimental basins
Systems	Economic efficiency	1950–1970	Operations research
Process	Water quality	1970–1990	Fast computing
Geosciences	Climate change	1990–2010	Remote sensing
Co-evolution	Human footprint	2010–2030	Big data

hydrological processes (Table 1). The current era is that of co-evolution, driven by human need and supported by big data.

Across research and higher education there is interest in fostering effective collaboration between universities and business. There is intense political scrutiny and encouragement to make this happen with numerous government-led reviews and changes in governance and funding support (Dowling, 2015; Hillier et al., 2019). The Triple Helix is one approach to conceptualizing the interaction between university-industry-government that has been proposed as key to improving the conditions for innovation in a knowledge-based society (Etzkowitz, 2003). The drivers for increased collaboration include the aspiration to convert excellence in research into business success, realizing the goals of universities to positively affect society through their research, economic growth and the increased capacity and capabilities of workers in both research and business (D'Este & Perkmann, 2011; Dowling, 2015; Lam, 2011). Debate continues about how to best incentivize, deliver, monitor and support such a change with a focus on both the motivators and barriers to such working (Hillier et al., 2019). In some cases collaborations have established incubators (as actual physical spaces) to promote innovation in water use and security, for example, the Water Council, a Wisconsin, US-based partnership of government, public sector, and universities within the state aims to promote “freshwater innovation” (Water Council, n.d.).

Existing research has thus demonstrated the role of technological, societal and political drivers in shaping and delivering new understandings in hydrological processes. In this paper we pose three research questions to explore in more depth how innovation can further our understanding of hydrological processes: (a) How does innovation increase our understanding of hydrological processes?; (b) Can working towards the sustainable development goals (SDGs) motivate innovation to drive research into hydrological processes? and (c) Can we develop new mechanisms to encourage innovation to increase our knowledge of hydrological processes? First we examine key aspects of innovation and explore innovation in the context of water security. Water security was selected since it is a pressing challenge and explicitly documented in the SDGs. We then present a series of innovation projects, using the case study approach, to determine their effectiveness in delivering innovation in managing hydrological processes, but also their contribution to scientific understanding. We conclude by proposing an approach for interdisciplinary collaboration aimed at increasing innovation in hydrological processes at regional scales that challenges “business as usual” in water related organizations. Insights

reveal how engagement with innovation processes generate positive outcomes for innovation and research.

2 | UNDERSTANDING THE ROLE OF INNOVATION IN HYDROLOGICAL PROCESSES

2.1 | Types of innovation

The fundamental definition of innovation was developed by Schumpeter (1934) who defined “innovations” as new combinations of production factors including the production of new goods, the introduction of new processes, the opening of new markets, the access to new sources of raw materials and intermediates, or the re-organization of an industry. Contemporary definitions have evolved this fundamental meaning, for instance Malerba (2000), to acknowledge that many innovations consist of new combinations of existing knowledge, involve new organizational forms, or the opening of new markets. Innovation can also be radical or incremental (Martin, 2016; Rossi, 2002). The concept of innovation is no longer seen as the simple application of codified knowledge, but as a process of creation of new, often tacit, knowledge (Rossi, 2002), including social change (Murray, Caulier-Grice, & Mulgan, 2010) and invisible innovation (Martin, 2016).

A range of types of innovation have been identified, including (George, McGahan, & Prabhu, 2012; Phills, Deiglmeier, & Miller, 2008; Yao, Li, & Weng, 2018):

- Product innovation: the creation and subsequent introduction of a good that is either new, an improved version of previous goods or services or the addition of a new feature to an existing product.
- Process innovation: continuous improvement in the combination of facilities, skills, and technologies used to produce, deliver, and support a product or provide a service.
- Service innovation: exceeding customer expectations.
- Management innovation: evolution and change in business strategies, systems and structures. Management innovation does not necessarily imply changes in the product or even in the production process, but in the way it is brought to the market.
- Open innovation: working beyond boundaries and collaborating globally.

- Social innovation: the process of developing and deploying effective, sustainable solutions to challenging social and environmental issues in support of social progress. For example, emissions trading, Fair Trade.
- Inclusive innovation: establishing new ideas that create opportunities to enhance social and economic well-being with the disadvantaged in mind.

2.2 | Innovation in hydrological processes

All types of innovation have been applied to, and in turn furthered, research in hydrological processes with some countries more innovative than others, especially those driven by challenges of water security (Table 2). Australia has many examples of management, service and open innovation to collaboratively manage water resources effectively across many stakeholders (Ayre & Nettle, 2017; Prosser et al., 2015). Singapore has driven product and management innovation to secure drinking water supply, integrating new technologies with new integrated methods of delivery (Hsien et al., 2019; Noguchi et al., 2019). There are also innovative examples of managing water resources post conflict in war torn countries such as Afghanistan (Habib et al., 2013). Hence water scarcity from many different causes has been a driver for innovation but also increased understanding of hydrological processes. Many of these innovations operate at large scales and are initiated by governmental and national funding drivers around management and social innovation, except for some product innovation which has been embedded through uptake of technological developments.

Different forms of innovation can lead to increased understanding of hydrological processes in a range of ways (Table 2). Product innovation has tended to result in increased understanding of hydrological processes at very small scales, but also transformative improvements in water quality through the supply chain. Process and management innovation have resulted in improved understanding in governance and management of hydrological processes, particularly in terms of meeting regulations through understanding multi-functionality of water resources. Social innovation has enabled researchers to understand hydrological processes from new perspectives and reflect on current theories of water transfer and transformations in quality. Service and open innovation have tended to drive co-evolution and mechanisms for knowledge sharing. However, reliance on large scale, top-down investment alone is unlikely to deliver the innovations necessary to mitigate current environmental challenges and new approaches to encourage innovation need to be explored.

3 | EXPLORING INNOVATION IN HYDROLOGICAL PROCESSES

To examine the ways in which innovation can be used to improve understanding of hydrological processes, we established an open innovation model for collaboration. The aim of this model was to

develop novel solutions for managing hydrological processes. We used the case study method to allow an in-depth study of individual, group, organisational, and/or business processes through real-life events (Yin, 2009). This approach permitted researchers to explore the unfolding and overlapping stories of innovation and learning within each case depicted, including those across the micro-, meso-, and macro-levels and with multiple actors (Schwandt & Gates, 2018).

3.1 | Project background

The North East (NE) Water Hub project was launched in 2017 as a collaborative partnership set in the North East of England between Durham County Council, Durham University, the Environment Agency, and Northumbrian Water, which sought to facilitate open innovation across the water sector within NE England and beyond. The project was part funded by the European Regional Development Fund (ERDF), with match funding from the organisations themselves. The project provided testing sites, research collaborations, grants to small and medium enterprises (SMEs) to support the development of innovations and delivered business support and networking opportunities to SMEs interested in innovating within the water sector. The project was designed to undertake an open innovation approach, underpinned by the Triple Helix (TH) model. The partnership represented the TH's triadic model: industry was represented by Northumbrian Water, the region's water utility firm; the government by the Durham County Council (local government) and the Environment Agency (UK government); and the university by Durham University. The overarching aims of the project were to: (a) establish a new collaboration to develop and embed innovative solutions to manage hydrological processes in partner organisations and (b) opening up of markets, related to the water and environment sector, for SMEs in smart specialization sectors. The Water Hub sought to provide access to opportunities to test products in real world settings, data, research institutes and government bodies. The project team identified predominantly two types of SMEs to support, one group referred to as the *digital SME* who were primarily offering a service to other partners/collaborators in the project. They were able to develop smart solutions (primarily as software, data analytics, visualizations) in collaboration with other SMEs, partners and end-users. The second group was the more traditional water/environment sector SMEs who had a product, rather than a service. These SMEs were hoping to develop smart upgrades to their existing products, secure places to test/validate their products, gain new business insight, develop research collaborations, or secure funding to support research and development (R&D).

The NE Water Hub aimed to deliver a collaborative network of support and innovation through a series of activities (Figure 1):

- Developing and rolling out opportunities for SMEs to respond to commercial challenges in the water sector through the partner organisations;

TABLE 2 Examples of innovation in hydrological processes

Water resource challenge	Solution
Product innovation	
Water conservation in Indonesia	Two types of domestic recharge wells were designed based on the hydrological data in Denpasar City-Indonesia. Both can meet the water demand of households (Sudijang, Wiraga, Parwita, & Santosa, 2017).
Managing storm water runoff	Technical implementation of a near-real-time location and temporally aware sensor network to monitoring permeable paver runoff (Rettig, Khanna, Beck, Wojcik, & McCane, 2016).
Clean drinking water supply in Singapore	Use of polymeric OF membrane in drinking water plants to produce high quality water while requiring a smaller resource footprint (Noguchi et al., 2019).
Process innovation	
The evaluation of changes in ecosystem services of catchments on the EU	DESSIN project: EU framework developed with a specific focus on freshwater ecosystems to allow for a more detailed exploration of practical implementation issues (Anzaldúa et al., 2018).
Management of post-conflict water resources, Afghanistan	Mainstreaming IWRM-SEA coalescence to bridge institutional gaps for better feedback between local and national water stakeholders, providing improved delivery of water services to sustain post-conflict socioeconomic recovery and promote environmental stewardship (Habib et al., 2013).
Soil and water conservation, Tanzania	Rethinking approaches for cascading proven innovations (such as terraces in vulnerable areas) rather than on generation of new technologies (Tumbo, Mutabazi, Byakugila, & Mahoo, 2011).
Service innovation	
Evolving farm management practices to improve water quality of the Great Barrier Reef	Growers were supported by trialling new concepts by an experienced team including farm extension and agronomic service providers, economists, suppliers, environmental consultants and communications specialists (Rouse & Davenport, 2017).
Management innovation	
Adopting source control interventions by water and sewerage companies, England and Wales	Regulation must (a) generate awareness of a performance gap so as to set an agenda for change and (b) create possibilities for implementation of innovation through enabling use of source control interventions where appropriate (Spiller, McIntosh, Seaton, & Jeffrey, 2015).
Storm water management, Melbourne	Design innovations, new catchment planning approaches, new best practice objectives, and new government policies to collectively change approaches to storm water management (Prosser, Morison, & Coleman, 2015).
Farm irrigation, Queensland	An agri-environmental incentive scheme was used to support on-farm implementation of environmentally sensitized irrigation practices using innovation brokers (Hood, Coutts, & Hamilton, 2014).
Water resources management through formal water rights and water fees systems, Tanzania	A mix of formal and traditional systems improved village-level water management services and reduced intra-scheme conflicts and water rights brought abstractions into line with allocations (Mehari, Koppen, McCartney, & Lankford, 2009).
Water scarcity in Singapore	Introduction of a diversified water cycle including: (a) water from local catchment (stormwater collected and stored in reservoirs), (b) imported water (from Johor river), (c) desalinated water, and (d) NE Water (highly purified reclaimed water) (Hsien, Low, Fuchen, & Han, 2019).
Open innovation	
Modernization of irrigation system in the Murray Darling Basin, Australia.	New joint strategic actions and new understandings, alliances, and roles between people and institutions for addressing irrigation modernization were crucial to establishing resilience assessment tools to change irrigation practices (Ayre & Nettle, 2017).
Collaborative water management, Norway.	New multilevel networks established in catchment areas, cutting across municipal, regional and national borders to establish common platforms of understanding to drive collaborative management (Hanssen, 2015).
Water resources management, South Africa.	Participatory monitoring of hydrological processes with a local community precipitated a learning opportunity and instilled a sense of ownership and management of natural resources (Kongo, Kosgei, Jewitt, & Lorentz, 2010).
Social innovation	
Governance of water resources, Australia.	Water Governance Research Initiative (WGRI) Australia: A learning system to provide opportunities for conversations, learning and reflection to emerge to manage water (Rubenstein, Wallis, Ison, & Godden, 2016).

(Continues)

TABLE 2 (Continued)

Water resource challenge	Solution
Blue green algae along the coast of Lieue-de-Greve, Cotes d'Armor	Schemes based on co-construction by local players and researchers aimed at encouraging a vision of innovation on a global scale and in the long-term, well beyond the conception phase (Levain, Vertès, Ruiz, & Delaby, 2014).
Managing non-point source pollution	Enabling social and institutional arenas to support emergent and adaptive management structures, processes and innovations is vital (Patterson, Smith, & Bellamy, 2015).
Innovation through water incubators	
The BREW accelerator	"The Water Council's BREW is the world's foremost freshwater business accelerator; connecting start-ups with resources, stimulating water-related innovation and bringing new, game-changing technologies to market in pursuit of real-world solutions to global freshwater challenges." (Water Council, n.d.)

Water Hub Open Innovation

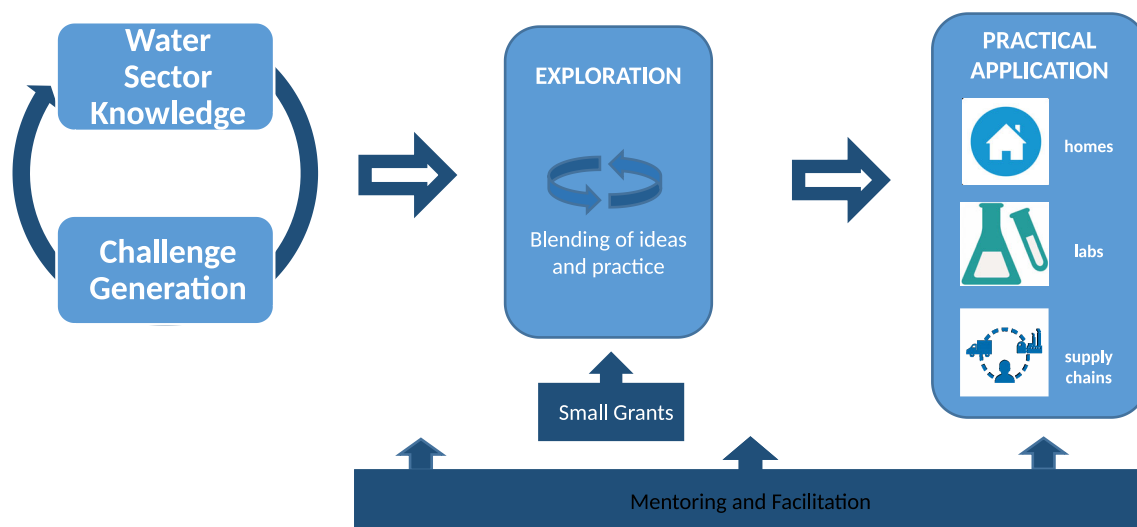
**FIGURE 1** An overview of the NE Water Hub

- Facilitating knowledge and technology transfer through partnership working between traditionally unconnected business sectors and research institutes in the region;
- Access to opportunities to test products in real world settings, business support, mentoring, networking events and finance to develop and test new innovations supporting delivery from concept to commercial product launch;
- Access to national and global networks and markets for future innovations and collaborations supporting the region's innovative ambitions and growth potential.
- A direct link to university-based research.

To drive the innovation system, staff from each organisation joined the project team on a fractional basis and co-located in the NE Water Hub offices alongside Water Hub staff employed specifically by the funding at Durham University. The project team members met on a regular basis across the triadic spheres of the project partners. The project was overseen by an Advisory Board that met quarterly

and a Management Board that met monthly to provide oversight and decision-making support for the project. While some elements of the project—innovation partnerships, grants, business support, and innovation events—were delivered more easily, the testing facility aim proved more of an ongoing challenge. Testing was achieved at specific sites, though it was not as widespread as the project team had hoped. This may be attributable to the additional resources required (time, money) and the complexities of trialling early-to-mid stage prototypes in the real-world.

Over the course of the project, 163 SMEs were supported by or engaged with the NE Water Hub, with approximately 1800 hours of networking, events, and support completed, with individual SMEs receiving or participating in anywhere from an hour to over 50 hours of supported activity over the duration of the project. The NE Water Hub project sponsored, co-sponsored, planned, or hosted 28 events between August 2017 and March 2020, with an overall, cumulative attendance well into the hundreds.¹ Eight SMEs received grant funding towards innovation projects; 20 engaged in research

collaborations; four SMEs brought new products to market and an additional 12 brought new-to-firm products. Seven new jobs were created through the project and 51 SMEs were provided with at least 12 hours of business engagement and support. Examples of products developed are: new street scale Sustainable Urban Drainage solutions; planters for rainfall attenuation in small, concrete yards; new ways of displaying data on Sustainable drainage systems (SUDs) to encourage changes in community behaviour to manage urban runoff; listening devices to monitor river flow; new designs for flood barriers; data sharing platforms; methods for monitoring peatland water tables; an app to conduct river surveys; and smart downpipes to enable reuse of rainwater.

The Water Hub was founded on an inclusive approach to project delivery to ensure engagement with a diverse range of stakeholders, knowledge, expertise and experience. However, a lack of diversity is widely recognized in the water and digital sectors. A 2016 profile of the UK water industry's workforce highlighted a lack of diversity: less than a fifth (19%) of employees identified as female, compared to 47% across all UK employment sectors (Energy & Utility Skills, 2017). Similarly, the UK Commission for Employment and Skills (UKCES) in 2015 found that in the digital and smart specialization sector only 26% of workers identified as female (UKCES, 2015). The Water Hub was female led: the core team (of eight staff) was 50% female, and the project's PI and advisory board Chair were both female. However, the composition of the advisory board was predominately male (75%). The team sought to deliver open and inclusive events and where possible, achieve gender balance, although this was not always achieved. While no specific gender, ethnicity or disability data was collected by the project on SME ownership, the SME beneficiary list reveals that only 20% of the key contacts for the Water Hub project were female (Ratnatunga, 2020). The project therefore mirrored the demographics of the sectors it was working in, though it actively strove to improve on those demographics as much as possible.

4 | THE NE WATER HUB INNOVATION ECOSYSTEM

The NE Water Hub engaged with a number of innovation types across the breadth of the project, aimed at facilitating innovation including product

itches, challenges, and funded grant schemes (Table 3). Some activities embraced nearly all types of innovations such as network activities, pitch my products and tenders, while other activities including grant schemes and open challenges focused more specifically on product and process innovation. Learning from the NE Water Hub suggests it is possible to tailor activities to target specific innovation types, but that encouraging many different types of innovation was readily achievable and desirable. Sections 4.1–4.3 outline specifically highlighted activities delivered to support different types of innovation and their outcomes in more detail.

4.1 | Process innovation

The management of urban drainage is a critically important challenge and developments in hydrological processes are key in managing extremes of rainfall (Chocat, Krebs, Marsalek, Rauch, & Schilling, 2001; Fletcher, Andrieu, & Hamel, 2013). In 2017, the NE Water Hub co-developed a tender with Durham County Council and the Environment Agency to address concerns over combined sewer overflows (CSOs) in heavy rainfall. CSOs are a vital part of the sewerage infrastructure, providing an option to discharge to a watercourse when the sewerage system is overloaded during storm events. They are designed to prevent the backflow of sewage into homes, but, as a consequence, discharge diluted sewage into rivers, lakes and seas, causing a range of ecological, public health and socio-economic challenges. SuDS are a key tool in the management of extremes of rainfall, limiting the volume of stormwater entering the combined sewer, and therefore the likelihood of CSO spills (Chocat et al., 2001; Fletcher et al., 2013). Yet stakeholder buy-in for SuDS is often limited by a lack of evidence and monitoring of systems that have been deployed. Little research has actively monitored the performance of SuDS and research undertaken tends to be qualitative or descriptive ranging from an annual site visit to take photographs, to fairly basic, routine maintenance (McDonald, 2018). There are fewer studies still that quantitatively measure the performance of SuDS, particularly in urban areas and/or retrofit scenarios due to the challenges in designing and implementing these studies. A research gap therefore exists about whether the SuDS systems are under or overperforming.

The tender was designed in a collaborative manner with input from all partners and developed a programme of work which included

TABLE 3 The range of activities and types of innovation involved in the NE Water Hub

Activity	Innovation type						
	Product	Process	Service	Management	Open	Social	Inclusive
Developing a new network		X		X	X	X	X
Pitch my product		X		X	X	X	X
Open challenges	X	X		X			
Grant scheme	X						
Hackathon	X	X	X				
Specific tenders	X	X	X	X	X	X	X
Test sites	X	X					

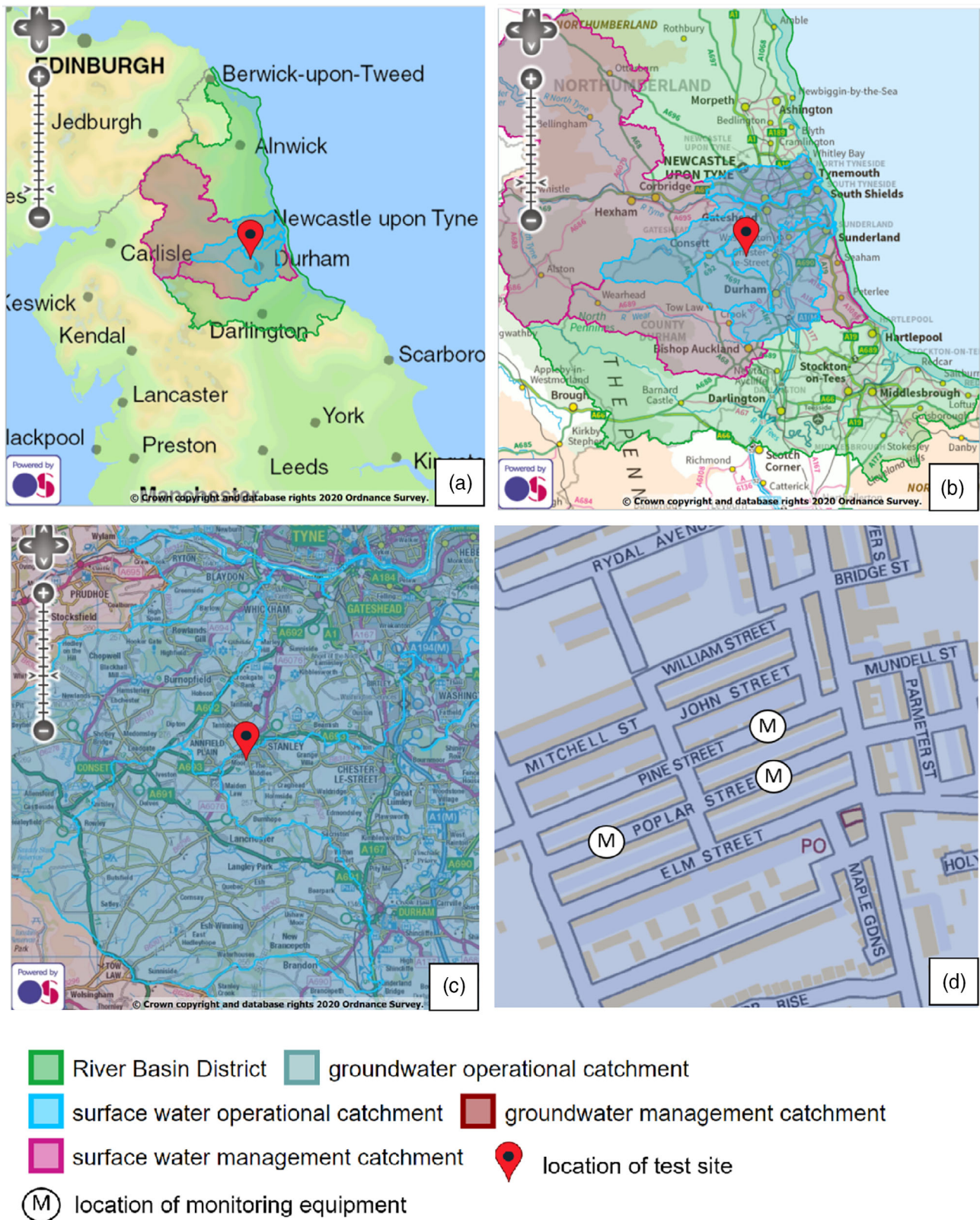

FIGURE 2 The study area (red pin) was located in the north east of England (a), within the Northumbria River Basin District (b) and the Wear Lower and Estuary Operational Catchment (c). The monitoring equipment was installed in three locations on two streets (d) (Environment Agency, 2020)

installing and monitoring innovative water infrastructure solutions in a study area around a “heavily modified” river with “moderate” ecological status (Environment Agency, 2020) (Figure 2). In addition to the environmental drivers, there were many socio-economic factors driving investment. The university coordinated a number of soft market events to facilitate collaboration between SMEs who could, in part, deliver the tender. As a result, a team of five businesses were brought together to retrofit water attenuation features, install technology to monitor performance and establish an engaged community group to support further investment in green infrastructure. Research supported the experimental design, deployment of sensors and analysis of data. Consultations and planning involved representatives from the water utility, the local authority, the environmental regulator and the team carrying out the civil engineering and groundworks. A programme of community engagement was undertaken alongside the structural work; community “champions” were established, to encourage the community to participate in informal drop in events (including gardening and maintenance of sustainable drainage features), and training and education around how to use the digital interface.

This collaboration demonstrates “process innovation” and how partnership working can increase capacity and resources available to public and private sector organisations, through access to facilities, technologies and perspectives they would not ordinarily be privy to. This case also highlights the importance of public buy-in for the likelihood of success of a holistic solution to a multi-faceted challenge. Community engagement with the new water infrastructure was mixed: the large group of “champions” were highly engaged, but this engagement was not widespread throughout the community. Some residents expressed concern over the maintenance and adoption of the new infrastructure, which is, unfortunately, a common theme for sustainable drainage systems (Melville-Shreeve et al., 2018). Better integration of the community into the innovation process, from the conceptual stage through to delivery, may help to ensure that deployed solutions are locally sustainable by aligning environmental (and government) priorities with community aspirations. In light of securing the tender and community feedback on products rolled out, some product evolution was also undertaken by some of the SMEs involved.

The scientific learning that resulted from the tender primarily focused on the challenges with quantitatively evidencing the benefits of SuDS. This included signal obstacles in wireless telecommunication services and logistical constraints of installing sensors in the drainage network. These challenges provide further opportunities to innovate to facilitate data collection on SuDS in urban environments. Qualitative support for partnership working was deemed to be crucial to increase the capacity for delivering SuDS and improving the likelihood of uptake. Widespread stakeholder support and community buy-in were found to be a solution to address the ongoing challenges faced with the adoption of property level SuDS.

4.2 | Product innovation

In 2018, a collaboration between the NE Water Hub and an SME launched an open call to develop a “smart” upgrade to an existing product.

The call sought to find a collaborative partner from the North East's established digital sector to co-create a data collection, monitoring and control system for a sustainable drainage system, designed to manage rainwater run-off from domestic, commercial and industrial roofs. Research supported the experimental design and project plan. The NE Water Hub facilitated meetings and knowledge sharing, between potential collaborators to find a hardware and software provider who met all of their criteria. The NE Water Hub supported the SME's joint application for funding for phase one prototype development through the “matched grant scheme” offered by the project. Funding was awarded and research supported the two businesses to develop and integrate the hardware and software necessary to collect quantitative data on product performance. This included integrating sensors to measure: soil moisture, water flow rate, and volume of water attenuated in real time. A bespoke weather station was linked with the product to enable the correlation of performance with particular storm events. Finally, the technical architecture required to store, transfer and analyse the collected data was developed. This study provided an evidence base from which the SME can further market their existing product, but also delivered additional features (such as the potential to control the product remotely based on the incoming data) which may expand the market interest in other, newer versions of the product. This phase one trial has seen a considerable advance in technology readiness level (TRL). The prototype (Figure 3) was validated in the laboratory (TRL4) and a relevant (household) location (TRL5). A full-scale technology demonstration, to evaluate the product in four different geographic regions of the UK is planned for 2020, taking this product innovation one step closer to commercialisation (TRL6). Research support is ongoing for experimental design, data collection and analysis.

This case study demonstrates product innovation but highlights how management innovation was also crucial to increase the TRL level. The outcome of the collaboration will be a new SuDS product on the open market. Like many SuDS solutions, this innovation will reduce the

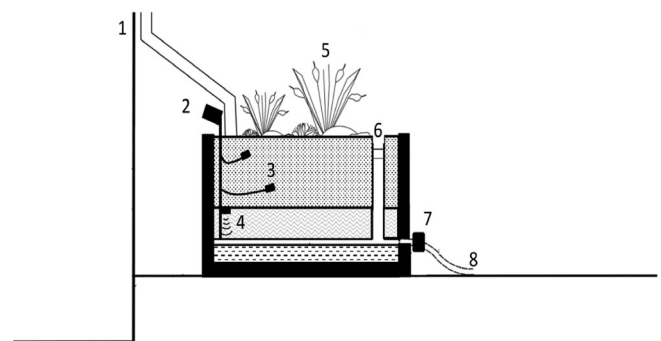

FIGURE 3 Schematic of the smart rainwater planter installed in phase 1 prototyping trials. The existing downpipe (1) is adapted to divert into the planter. There is an integrated weather station (2) which collects temperature, humidity, barometric pressure, and rainfall data. Sensors for soil moisture (3) and stored water level (4) are integrated within the planter. The device also contains plants (5), an overflow pipe (6), and flow monitoring (7) on the outflow pipe (8). Any rainwater which is not attenuated or used by the plants is discharged to nearby rain gardens, pervious paving or the sewer network

TABLE 4 Details of the pitch my product events

Development	Warehouse	Cafe
Scale	2.5 million square foot regional/national distribution centre accommodating ~1,000 staff and a fleet of HGVs/delivery vehicles.	A visitor and events hub including a café, six public toilets and three staff toilets.
Key water resource challenges	<ol style="list-style-type: none"> 1. Manage runoff from hard-standing 2. Reduce water-related risk (e.g., leaks, burst etc within the building) 3. Prevent pollution incidents into nearby waterbody 4. Improve building water efficiency 	<ol style="list-style-type: none"> 1. Reduce water use in the café & public toilets 2. Encourage rainwater harvesting for non-potable use 3. Promote biodiversity through green spaces 4. Reduce waste 5. Connect communities through smart technology
Number of pitches submitted	15	12
Number of pitches selected to present	8	9
Number of pitches followed up for original development	0	3
Number of pitches followed up for inclusion in other developments	5	1

quantity, and increase the quality, of storm water runoff. However, it enables both a proactive and reactive approach to managing urban water resources in extreme conditions. The integration of sensors and the interpretation of multiple data streams enables smart, informed decision making on the timing and quantity of stormwater discharge to the sewer network. This enables dynamic management of the infrastructure's capacity and could lead to considerable reductions in CSO spills. To evolve the product new data sets were created including rainfall, temperature, soil moisture and water transfer within the product. Analysis of this data provided new understanding of hydrological processes at the micro scale in urban environments.

4.3 | Management innovation

The NE Water Hub pioneered two events where SMEs were able to "pitch their products" to developers in the NE. One pitch event enabled SMEs to showcase products for controlling runoff and increasing water (and energy) efficiency in a large warehouse development. The second event, for a small-scale cafe development, sought SuDS solutions and products to improve water efficiency and promote water reuse (Table 4). These pitching opportunities encouraged evolution and change in business strategies that would benefit those responsible for design and project management, making them aware of alternative solutions that could be used to manage water resources. Some of the products pitched were new to market looking for test sites and/or commercial uptake, others were more established, with the SMEs seeking to increase their share of the market. This "pitch my product" process was a new way to evaluate options for technological solutions from a range of suppliers, but also brought collaborators together in new ways.

To facilitate the pitches a design brief was written in collaboration between researchers and the sponsor organisation, this outlined the specifications of the development and the types of water resource challenges that the developers were keen to address. A call was issued using the NE Water Hub network for pitches that mapped onto the agreed scope. The call was followed by a pitch event for selected submissions that met the agreed criteria to showcase products to a judging panel that comprised the sponsor organisation and relevant NE Water Hub partners. The judging panels at both events included developers, construction contractors, project leads, engineering consultants, local authorities and researchers. Lastly, pitches were judged and open discussions held between the judging panel about relevance, fit and potential of the products to the design brief. Contact was then facilitated between the developer and SMEs so the sponsor could follow up with any products in which they were interested. Outcomes of the "pitch my product" session for the warehouse development did not result in any products being included in the advertised opportunity, but the developers followed up with five SMEs who pitched for other developments. The pitch for the cafe development resulted in conversations with three products for the cafe, but also follow up with one more SME for a separately funded project.

These pitch events provided those present with a new method for evaluating best practice, introduced them to technological solutions with which they were previously unfamiliar. This example of management innovation demonstrates evolution and change in business strategies rather than development of new products, but also encompasses open, social and inclusive innovation. This test case demonstrates the potential for management innovation in the water sector and the effectiveness of "pitch my product" opportunities for both developers and SMEs. The pitch events did not lead directly to evolution of understanding of hydrological processes but did increase

the appreciation of societal benefits of more effective management of water resources, which in turn might lead to future product evolution.

5 | DISCUSSION

Innovation in managing hydrological processes is a global initiative to try to meet challenges around water security. Large scale open innovation approaches have been developed across the globe, for instance Singapore's Imagine H₂O, a regional accelerator and customer validation platform for global water start-ups (Imagine H₂O, n.d.), and Sweden's WIN Water, an incubator with a Green Innovation Park (Win Water, n.d.). These examples typify the large-scale public-private initiatives to try to speed up the process of getting innovations to the market (Win Water, n.d.). Such mechanisms have been employed to integrate innovation and research to increase our understanding of hydrological processes. In this paper we have reported new ways to drive a range of types of innovation in managing hydrological processes using a collaborative model of research and innovation. Our research demonstrates that managing hydrological processes is, and can be, a site and source of open innovation and innovative learning through a collection of smaller scale activities. Innovation can emerge through internal collaboration mechanisms or through cross-helix forms of interaction, such as the research-business-innovation models.

Our research confirms that innovation can lead to advances in understanding hydrological processes. The examples in Sections 4.1 and 4.2 demonstrate how process and product innovation can directly advance understanding of hydrological processes, through the drive for new data and the application of new products in real world settings. Novel process understandings were essential to the development of new products, for instance the SuDS solutions were founded on research into flow processes at small scales and were developed using meteorological data and runoff data from impervious surfaces. However, management innovation had a less direct route to evolving scientific understanding and was more effective in shaping uptake of technology. Our findings agree with Sivapalan and Blöschl (2017) that innovation to meet societal needs can drive research. Sivapalan and Blöschl (2017) have mapped out the current era from 2010–2030 as one of co-evolution, driven by the societal need of the human footprint, reliant on advances in big data. The dominant paradigms of the era are yet to be agreed and we suggest there is scope to explicitly recognize the need for sustainable solutions at multiple scales to integrate research and innovation.

There are many examples where innovation has already resulted in research to address the SDGs (Table 2). Our own research demonstrates that small scale, local investment in innovation around hydrological processes can lead to fundamental change in practices of organisations to help meet global challenges encapsulated in the SDGs. The drive to meet the SDGs was central to opening up opportunities for funding and the take up of novel solutions within our partner organisations. The drive for water efficiency, flood mitigation and reducing runoff were central to the organisations involved in the NE Water Hub which encouraged them to support product testing, share knowledge

and data to support product development and to purchase new products. Innovation was a useful way to engage partners in research.

Our research demonstrates that innovation in hydrological processes crosses all types of innovation. Some of the activities we organized targeted specific types of innovations (e.g., grants, specific organisational challenges), but others embraced a greater range of innovation types and could be designed purposefully to do this (e.g., product pitches and tenders). Outcomes of the NE Water Hub have included changing behaviour and adapting processes within partner organisations, the willingness of partners to look beyond their usual supply chains for solutions, an interest in reflecting on best practice to find more innovative solutions and new research. These outcomes will hopefully feedback into continued support for future innovation ecosystems and research.

Based on learning from the NE Water Hub (Figure 4) outlines the key components of a model for collaborative working across research, industry and government. Figure 4 goes further than the usual triple helix model to include key elements and activities to drive collaboration and deliver outcomes to meet the SDGs. Hillier et al. (2019) detailed tensions for researchers between delivering non-optional duties (teaching, research and administration) and extra resources necessary to work with business. The approach taken in the NE Water Hub demonstrates how open collaboration can be used to deliver business innovation and research, feeding into university impact work, but working within available capacity across organisations. The relationship between open collaboration and growing trusted working environments enables expertise, data and knowledge to be shared across the organisations involved more effectively to the benefit of all. The sector knowledge, exploration and practical application can be co-designed from multiple perspectives to ensure that activities fit into, and deliver solutions, that map closely onto the objectives of the partners involved. Such a way of working improves the relevance of the work undertaken, increasing the effectiveness and ability of organisations to engage within the capacity available.

While our research was regionally based, the opportunities developed attracted SMEs from all over the UK. Innovation ecosystems around hydrological processes therefore have a huge potential to benefit water security challenges as well as business growth and research. The collaboration made it possible for new research questions to be developed, which in turn shaped the research and innovation agendas of the NE Water Hub. Open innovation was crucial to the success of the NE Water Hub in delivering change. The management structure of the NE Water Hub was unique with the team having one foot in their own organisation, and the other in the Water Hub. In this way, the NE Water Hub became embedded in the partner organisations which enabled opportunities to be developed that benefitted both the organisations themselves, as well as SMEs providing the innovations. This win-win way of working ensured that expert knowledge from organisational perspectives was available to those developing innovations for managing hydrological processes and that innovations were taken up by partners (including research opportunities).

The model outlined in Figure 4 has the potential to be applied in other markets, sectors or countries interested in applying a Water Hub



FIGURE 4 A trusted innovation ecosystem to integrate business and research to deliver solutions to address the sustainable development goals (SDGs)

approach to water sector smart specialization that integrates innovation and research. The UK has relatively good open datasets and a mature and tight regulatory landscape in comparison to many countries, which provided the foundation for the collaboration; partners had some prior experience of working together and the challenges faced across organisations. The ERDF funding provided the catalyst for the collaboration between partners, although the funding scheme demanded match funding from all involved. The match funding was secured due to the potential benefits that all partners could see in the open innovation ecosystem. It is evident from the delivery of the NE Water Hub that the open collaboration, high levels of trust and investing time in developing a range of activities that were tailored to meet the needs of all partners involved led to the success of the project. Ensuring these characteristics should enable collaborations to work around limitations of different regulatory settings such as state-ownership, limited data access and control, and access to government-sponsored funding.

However, while there is evidence of good practice from the NE Water Hub, challenges and difficulties were also experienced. Connections between projects were often fragmented or lost due to project and staff turnover. Poor communication across networks and systems of innovation were also evident that disconnected organisations from innovation and/or research. Organisational processes regularly presented challenges; regulatory and legal processes made it difficult to share data, organisational inertia meant new practices and

products could not always be taken advantage of and long term agreements with companies to deliver products and services stifled innovation. These disconnects can render systems of innovative practice and the “learning environment” that Etzkowitz (2014) spoke about ineffective, disable opportunities for open innovation and impair the triple helix model's potential for a sustainable innovation ecosystem. Intellectual property (IP) is often cited as a challenge for working across business and research (e.g., Dowling, 2015; Hillier et al., 2019), but this did not present any challenges in the NE Water Hub. This was because IP was discussed and negotiated on a case by case basis as innovations were developed. Working in a trusted and open collaboration enabled discussion and negotiation at an early stage to avoid issues around IP.

The NE Water Hub was focused around a sector which lacks diversity and is dominated by a male workforce (Energy & Utility Skills, 2017; UKCES, 2015). There is a wealth of research exploring women's underrepresentation in science and we do not wish to explore this here. Rather we wish to round out the picture, and “reclaim” the ways in which women can and do make spaces in what is undoubtedly a male dominated environment. The project was not a traditional research project funded by core government investment in research. Rather it was a collaborative project funded to drive business growth by integrating research, policy and practice. Thus from a career perspective this was a risky project for academic researchers to undertake: it might not have produced academic outputs, demanded

detailed evidence to be collected and outputs predominantly focused on businesses. It is notable that the project lead and the new staff appointed to the project were all female. The team benefitted from strong communication, collaborative and organisation skills alongside research expertise in hydrological processes, the water sector and digital skills. The ability to flex and evolve were crucial to enable the team to deliver the project. This demonstrates that there are stories to tell around the opportunities and enjoyment that can be a part of innovation in the water sector and the danger in “over-privileging” innovation and the water sector as a site of “hyper-masculinity.” We hope to add our voices to those promoting a more inclusionary set of images and practices. Future projects should work to ensure inclusive approaches to both the methods of innovation research within the hydrological field but also to welcome a wider range of perspectives and creative approaches to ensure innovation is included and truly embedded in the field.

6 | CONCLUSIONS

Innovation and understanding of hydrological processes are intimately linked. Innovation is central to delivering behaviour change to address the SDGs but can also play a role in furthering scientific understanding of hydrological processes. Many countries have established large scale investment in accelerator and incubator programmes to help deliver these innovations (USA, Singapore, Australia and Sweden). The challenge now is to develop new ways of working to innovate at more local and regional scales, ensuring innovation and research support each other. All types of innovation can support management of hydrological processes and the case study methodology provided a useful mechanism for tracing and articulating these forms of innovation in hydrological processes. Different activities support different types of innovation, for instance, tenders and small grants tended to lead to product and process innovation, but product pitches were more important for cascading solutions and increasing their uptake by partners. Product and process innovation were more closely related to increasing scientific understanding of hydrological processes than other forms of innovation. The NE Water Hub demonstrated that the design of the innovation ecosystem was crucial to its success and delivering behaviour change within organisations. It can be used as a model to roll out trusted ecosystems to integrate innovation and research more widely to further scientific understanding and deliver behaviour change to address the SDGs.

ACKNOWLEDGEMENTS

We thank the following: (a) European Regional Development Funding (ERDF) for supporting The NE Water Hub; (b) our project partners Durham University, Durham County Council, Northumbrian Water Limited and the Environment Agency; (c) our collaborators Ashleigh Adey, Niall Benson, Nicola Bramfitt, Adrian Cattle-Jones, Anna Gerring, George Gerring, Chris Jones, Jackie McKenna, and Rachel Murphy; and (d) the SMEs across the country who participated in and engaged with the NE Water Hub project.

DATA AVAILABILITY STATEMENT

Data sharing is not applicable to this article as no datasets were generated or analysed during the current study. All information on the NE Water Hub can be found at <https://www.thewaterhub.org.uk/>.

ORCID

Louise J. Bracken  <https://orcid.org/0000-0002-1268-5516>

ENDNOTE

¹ This planning included the project's Ripple 2020, which was scheduled for March 18, 2020 and had a planned attendance of 100 participants, including representatives from 27 SMEs. This was cancelled on March 11, 2020, due to the Covid-19 pandemic.

REFERENCES

- Anzaldúa, G., Gerner, N. V., Lago, M., Abhold, K., Hinzmann, M., Beyer, S., ... Amorós, J. (2018). Getting into the water with the Ecosystem Services Approach: The DESSIN ESS evaluation framework. *Ecosystem Services*, 30, 318–326.
- Ayre, M., & Nettle, R. (2017). Enacting resilience for adaptive water governance: A case study of irrigation modernization in an Australian catchment. *Ecology and Society*, 22(3). <http://www.jstor.org/stable/26270144>
- Chocat, B., Krebs, P., Marsalek, J., Rauch, W., & Schilling, W. (2001). Urban drainage redefined; from stormwater removal to integrated management. *Water Science and Technology*, 43(5), 61–68.
- D'Este, P., & Perkmann, M. (2011). Why do academics engage with industry? The entrepreneurial university and individual motivations. *The Journal of Technology Transfer*, 36, 316–339.
- Dowling, D. A. 2015. *The Dowling review of business-university research collaborations*. Retrieved from <https://www.gov.uk/bis>
- Energy & Utility Skills. (2017) *Water industry: Workforce and skills profile* [Online]. Retrieved from <https://www.euskills.co.uk/wp-content/uploads/2018/05/Water-Profile-2017-Final-140518-v2.pdf>
- Environment Agency (2020) *Catchment data explorer - Twizell burn from source to Cong Burn*. EA Catchment Plan. Linked Data Portal. Retrieved from <http://environment.data.gov.uk/catchment-planning/WaterBody/GB103024077590>
- Etzkowitz, H. (2003). Innovation in innovation: The triple helix of university-industry-government relations. *Social Science Information*, 42, 293–337.
- Etzkowitz, H. (2014). Making a humanities town: Knowledge-infused clusters, civic entrepreneurship and civil society in local innovation systems. *Triple Helix*, 1(12), 1–22.
- Fletcher, T. D., Andrieu, H., & Hamel, P. (2013). Understanding, management and modelling of urban hydrology and its consequences for receiving waters; a state of the art. *Advances in Water Resources*, 51, 261–279.
- George, G., McGahan, A. M., & Prabhu, J. (2012). Innovation for inclusive growth: Towards a theoretical framework and a research agenda. *Journal of Management Studies*, 49(4), 661–683.
- Habib, H., Anceno, A. J., Fiddes, J., Beekma, J., Ilyuschenko, M., Nitivattananon, V., & Shipin, O. V. (2013). Jumpstarting post-conflict strategic water resources protection from a changing global perspective: Gaps and prospects in Afghanistan. *Journal of Environmental Management*, 129, 244–259.
- Hanssen, G. S. (2015). Multi-level networks: Strengths and weaknesses in promoting coordinated and innovative water governance. In A. Agger, B. Damgaard, A. Krogh, & E. Sorenson (Eds.). *Collaborative governance and public innovation in Northern Europe* (p. 133). Sharjah, UAE: Bentham Science Publishers.
- Hillier, J. K., Saville, G., Smith, M. J., Scott, A. J., Raven, E. K., Gascoigne, J., ... Leckebusch, G. C. (2019). Demystifying academics to enhance

- university-business collaborations in environmental science. *Geoscience Communications*, 2, 1–23. <https://doi.org/10.5194/gc-2-1-2019>
- Hood, O., Coutts, J., & Hamilton, G. (2014). Analysis of the role of an innovation broker appointed by a cotton industry environmental innovation partnership in Queensland, Australia. *Outlook on Agriculture*, 43(3), 201–206.
- Hsien, C., Low, J. S. C., Fuchen, S. C., & Han, T. W. (2019). Life cycle assessment of water supply in Singapore—A water-scarce urban city with multiple water sources. *Resources, Conservation and Recycling*, 151, 1044–1076.
- Imagine H₂O. (n.d.). *A Singapore-based, regional accelerator and customer validation platform for global water startups*. Retrieved from <https://www.imagineh2o.org/ih2oasia>
- Kongo, V. M., Kosgei, J. R., Jewitt, G. P. W., & Lorentz, S. A. (2010). Establishment of a catchment monitoring network through a participatory approach in a rural community in South Africa. *Hydrology and Earth System Sciences*, 14(12), 2507–2525.
- Lam, A. (2011). What motivates academic scientists to engage in research commercialization: 'Gold', 'ribbon' or 'puzzle'? *Research Policy*, 40, 1354–1368.
- Levain, A., Vertès, F., Ruiz, L., & Delaby, L. (2014). Coordinating the injunction to change and innovation processes in a territory where ecological issues are a major challenge: Cross-perspectives on an experimental approach. *Fourrages*, 217, 69–78.
- Malerba, F. (2000). *Economia dell'innovazione*. Roma, Italy: Carrocci.
- Martin, B. R. (2016). Twenty challenges for innovation studies. *Science and Public Policy*, 43(3), 432–450. <https://doi.org/10.1093/scipol/scv077>
- McDonald, R. K. (2018) *Sustainable urban drainage systems (SUDS) in Scotland: Assessment of monitoring and maintenance within local authorities and Scottish water* [Online]. Retrieved from https://www.climatexchange.org.uk/media/3239/sustainable_urban_drainage_systems_in_scotland.pdf
- Mehari, A., Van Koppen, B., McCartney, M., and Lankford, B. (2009) Unchartered innovation? Local reforms of national formal water management in the Mkoji sub-catchment, Tanzania. *Physics and Chemistry of the Earth, Parts A/B/C*, 34:4–5, pp. 299–308. <https://doi.org/10.1016/j.pce.2008.07.009>
- Melville-Shreeve, P., Cotterill, S., Grant, L., Arahueter, A., Stovin, V., Farmani, R., & Butler, D. (2018). State of SuDS delivery in the United Kingdom. *Water and Environment Journal*, 32, 9–16.
- Murray, R., Caulier-Grice, J., & Mulgan, G. (2010). *The open book of social innovation*. London, England: Young Foundation.
- Noguchi, H., Oo, M. H., Niwa, T., Fong, E., Yin, R., & Supaat, N. (2019). Applications of flat sheet ceramic membrane for surface water and seawater treatments - Introduction of performance in large-scale drinking water plant and seawater pretreatment pilot system in Singapore. *Water Practice and Technology*, 14(2), 289–296.
- Patterson, J. J., Smith, C., & Bellamy, J. (2015). Understanding enabling capacities for managing the 'wicked problem' of nonpoint source water pollution in catchments: A conceptual framework. *Journal of Environmental Management*, 128, 441–452.
- Phills, J. A., Deiglmeier, K., & Miller, D. T. (2008). Rediscovering social innovation. *Stanford Social Innovation Review*, 6(4), 34–43.
- Prosser, T., Morison, P. J., & Coleman, R. A. (2015). Integrating stormwater management to restore a stream: Perspectives from a waterway management authority. *Freshwater Science*, 34(3), 1186–1194.
- Ratnatunga, S. (2020). *The water hub project: Summative assessment: April 2020*. Newcastle: Ideas for Change Consulting Ltd.
- Rettig, A. J., Khanna, S., Beck, R. A., Wojcik, Q., & McCane, C. A. (2016). Monitoring permeable paver runoff with an open-innovation geospatial sensor network. *International Journal of Digital Earth*, 9(1), 30–46.
- Rollason, E., Bracken, L. J., Hardy, R. J., & Large, A. R. G. (2018). The importance of volunteered geographic information for the validation of flood inundation models. *Journal of Hydrology*, 562, 267–280.
- Rossi, F. (2002). *An introductory overview of innovation studies* (Working paper 1-32). Retrieved from <https://mpr.aub.uni-muenchen.de/9106/>
- Rouse, A., & Davenport, C. (2017). Project Catalyst: An innovation project for cane growers in the Great Barrier Reef catchment. *Rural Extension & Innovation Systems Journal*, 13(2), 167.
- Rubenstein, N., Wallis, P. J., Ison, R. L., & Godden, L. (2016). Critical reflections on building a community of conversation about water governance in Australia. *Water Alternatives*, 9(1), 81–98.
- Schumpeter, J. (1934, Italian ed. 1971). *Theory of economic development (Teoria dello sviluppo economico)*. Firenze, Italy: Sansoni.
- Schwandt, T. A., & Gates, E. F. (2018). Case study methodology. In N. K. Denzin & Y. S. Lincoln (Eds.), *The SAGE handbook of qualitative research* (5th ed., pp. 341–358). Thousand Oaks, CA: SAGE Publications.
- Sivapalan, M., & Blöschl, G. (2017). The growth of hydrological understanding: Technologies, ideas, and societal needs shape the field. *Water Resources Research*, 53(10), 8137–8146.
- Spiller, M., McIntosh, B. S., Seaton, R. A., & Jeffrey, P. J. (2015). Integrating process and factor understanding of environmental innovation by water utilities. *Water Resources Management*, 29(6), 1979–1993.
- Sudijang, L., Wiraga, I. W., Parwita, I. G. L., & Santosa, G. (2017). Domestic recharge wells for rainwater-harvesting in Denpasar City, Bali-Indonesia. *International Journal of GEOMATE*, 13, 50–57.
- Tauro, F., Selker, J., Van De Giesen, N., Abrate, T., Uijlenhoet, R., Porfiri, M., ... Ciruolo, G. (2018). Measurements and observations in the XXI century (MOXXI): Innovation and multi-disciplinarity to sense the hydrological cycle. *Hydrological Sciences Journal*, 63(2), 169–196.
- Tumbo, S. D., Mutabazi, K. D., Byakugila, M. M., & Mahoo, H. F. M. (2011). An empirical framework for scaling-out of water system innovations: Lessons from diffusion of water system innovations in the Makanya catchment in Northern Tanzania. *Agricultural Water Management*, 98(11), 1761–1773.
- UKCES. (2015) *Opportunities and outcomes in education and work: Gender effects*. Retrieved from https://assets.publishing.service.gov.uk/government/uploads/system/uploads/attachment_data/file/477360/UKCES_Gender_Effects.pdf
- Water Council. (n.d.) *Brew accelerator: World's foremost freshwater seed accelerator*. Retrieved from <https://thewatercouncil.com/programs/brew-accelerator/>
- Watson, N., & Howe, J. (2006). Implementing the EU water framework directive: Experiences of participatory planning in the Ribble Basin, North West England. *Water International*, 31, 472–487. <https://doi.org/10.1080/02508060608691951>
- Win Water. (n.d.) Retrieved from <https://winwater.se/>
- Yao, W., Li, H., & Weng, M. S. (2018). The role the university could play in an inclusive regional innovation system. *Triple Helix*, 5, 12–21.
- Yin, R. K. (2009). *Case study research: Design and methods* (4th ed.). Thousand Oaks, CA: SAGE publications.

How to cite this article: Bracken LJ, Cockshut L, Taylor J, Cotterill S. The role of innovation in advancing understanding of hydrological processes. *Hydrological Processes*. 2020;34: 4404–4416. <https://doi.org/10.1002/hyp.13890>